



**Assembly
&
Installation Instructions**

**FOR
SUBFRAME COMPONENTS PACKAGE 99100396
INCLUDES
SUBFRAME NOSE PIECE 96103551**

**TO FIT
1999 - LATER FORD F250 & F350 SUPER DUTY SERIES 4x4**

©2004 Sno-Way® International

97100635F



1. THINK SAFETY, ALWAYS WEAR SAFETY GLASSES WHEN PERFORMING THE OPERATIONS PRESCRIBED IN THESE INSTRUCTIONS
2. READ ALL INSTRUCTIONS CAREFULLY BEFORE ATTEMPTING INSTALLATION
3. BEFORE BEGINNING WORK MAKE SURE TO SET PARKING BRAKE AND CHOCK WHEELS



MINIMUM VEHICLE RECOMMENDATIONS

Heavy Duty Alternator Heavy Duty Battery
 Manufacturers Snow Plow Package

NOTE: On some vehicles it may be necessary to use a form of load booster to decrease the vehicle's front suspension sag with the snow plow in place. This can be accomplished with the use of supplementary air bags, booster springs, or similar load boosting devices. Since there are different load boosting devices available, it will up to the customer/end user to decide and purchase the product to suit the application, and not the responsibility of Sno-Way International, Inc.

ASSEMBLY TOOLS NEEDED

Drill Bits 1/4", 17/32"
 Impact Sockets 7/16" – 1-3/8"
 Impact Sockets Metric 10mm – 19mm
 Wrenches 7/16" – 1-3/8"
 Wrenches Metric 10mm – 19mm
 Torque Wrench Rat Tail Pry Bar
 Center Punch and Hammer
 Clamping Device ("C", Bar, type device...)

INSTALLATION NOTES

1. Unless otherwise specified, mount all Sub-Frame Components to vehicle before tightening any hardware.
2. It is recommended that LOCTITE®, or similar thread locking product, be used on ALL mounting hardware (i.e. Nuts, Cap Screws, Bolts, etc.).
3. Vehicle should be parked on a level surface with a normal vehicle load on the FRONT suspension.
4. Items in parentheses () refer to quantity required for this step. Items in parentheses with a pound sign (#) indicate the part number as found in the parts list on the last page of this document.
 Example: (2) 1/2" x 13 x 1-1/2" Cap Screws (#9).
5. It maybe necessary to relocate license plate holder. Check state and local laws for placement, if needed.

MOUNTING INSTRUCTIONS

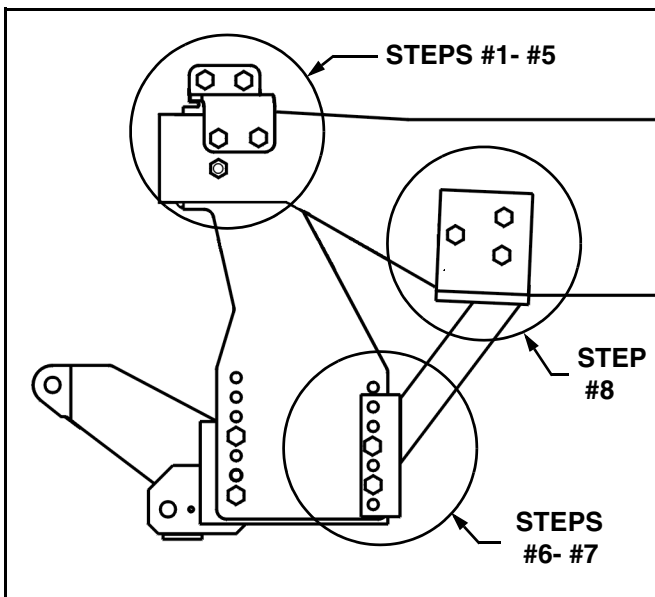

1. Unsnap rubber portion of air dam and other items, if equipped, so that the front bumper can be removed completely. Remove vehicle front bumper assembly, by removing the four (4) nuts that secure the bumper to the bumper support. Retain, with hardware, for replacement at end of installation.
2. Align the Front Plates (#2 & #3) on either side of the inside of the frame with existing holes on the bumper mounting plate. Insert (4) Carriage Bolts (#10) in the square holes on the inward side of the tow hooks and secure the Front Plates with (4) Lock Washers (#14) and (4) 1/2" Hex Nuts (#15).



WARNING

According to the Ford Owner Guide, removing the BlockerBeam™ without installing snow plow attachment hardware may affect air bag deployment in a crash. DO NOT operate the truck unless either the BlockerBeam™ or snow plow attachment hardware is installed on the vehicle! FAILURE TO HEED CAN RESULT IN SERIOUS INJURY OR DEATH!

- Position the Front Brackets (#4 & #5) over the top of the truck frame and secure to the Front Plates (#2 & #3) with (4) 1/2" x 1-1/2" Cap Screws (#9) and (4) 1/2" Nylock Nuts (#12). Tighten the Nuts for proper alignment in the following steps.

WARNING

Beware of brake and fuel lines secured to inside wall of frame rails when drilling holes in vehicle frame!

FAILURE TO HEED CAN RESULT IN SERIOUS INJURY OR DEATH!

- Using the Front Plates and Brackets as a template, drill 1/4", then 17/32" holes through the sides of the truck frame in six places. Secure using (6) 1/2" x 1-3/4" Cap Screws (#13) and Nylock Nuts (#12).
- Attach Nose Piece Assembly (#1) to the Front Plates (#2 & #3) in the front set of vertical holes and secure using (4) 1/2" x 1-1/2" Cap Screws (#9) and (4) Nylock Nuts (#12).
- Align the lower portion of the LH and RH Rear Brackets (#6 and #7) with the back holes in the Front Plates and Nosepiece.
- Secure loosely the Rear Brackets (#6 and #7) to the Front Plates (#2 and #3) and Nosepiece (#1) using (4) 1/2" x 2-1/4" Cap Screws (#16) and (4) Nylock Nuts (#12).

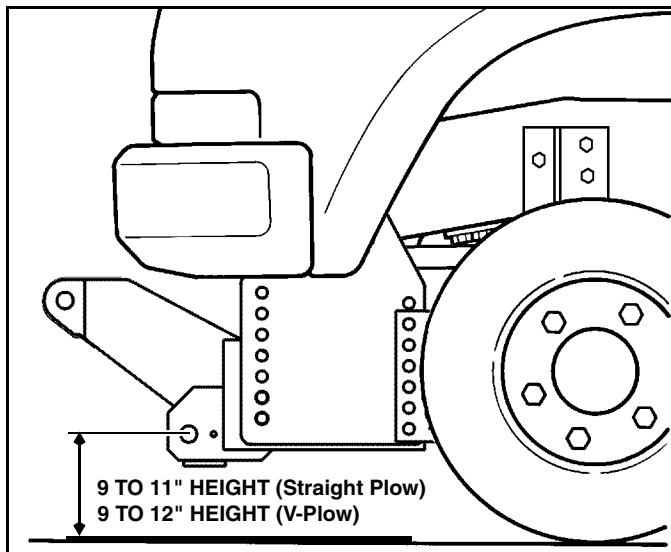

IMPORTANT: Height from the center of the lower Plow Mounting holes on the Sub-Frame to the ground should be between 9" and 11" for straight plows, and between 9" and 12" for V-plows to insure proper operation. On some vehicles it may be necessary to use a form of load booster (See note page 1, Minimum Vehicle Recommendations).

- Position the LH and RH Rear Brackets (#6 and #7) firmly against the side and bottom of the truck frame. **Note that the Brackets may not lay flush against the bottom of the frame at this point. They may be interfering with an existing rivet in the frame. Be sure that the side of the Brackets are flush against the side of the frame, and continue the installation.**
- Using the holes on the side of the Rear Brackets as a template, drill 1/4", then 17/32" holes in the vehicle frame. Insert Nut Plate Assembly (#8) through the opening in the front of the vehicle frame and align with the drilled hole. Secure with 1/2" x 1-1/2" Cap Screw (#9) and Lock Washer (#14). Repeat this procedure for the other holes.
- Using the Torque Specification Chart below, torque all bolts **starting at the rear** and working forward.
 - Reinstall bumper and all other items previously removed. Position (4) 1/2" Flat Washers (#11) on the existing bumper bolts between the bumper brackets and the bumper supports on the vehicle when replacing the front bumper.

TORQUE SPECIFICATIONS FOR STANDARD MACHINE HARDWARE					
Bolt Size	GR.2 Dry	GR.5 Dry	GR.8 Dry	Metric Size	GR.8.8 Dry
1/4"	66*	9	12	M8	17
5/16"	11	17	25	M10	35
3/8"	20	30	45	M12	60
7/16"	32	50	70	M14	95
1/2"	50	75	110	M16	155
9/16"	70	110	150		
5/8"	100	150	220		
3/4"	175	260	380		
7/8"	170	430	600		
1"	250	640	900		

Note: These torque values are to be used for all hardware. Unless otherwise specified, all torque values must meet this specification.
 Note: All torque values are in Ft.-Lbs unless otherwise stated
 Note: *In-Lbs

REMEMBER After 5 to 10 hours of snowplow usage, re-torque all Cap Screws!

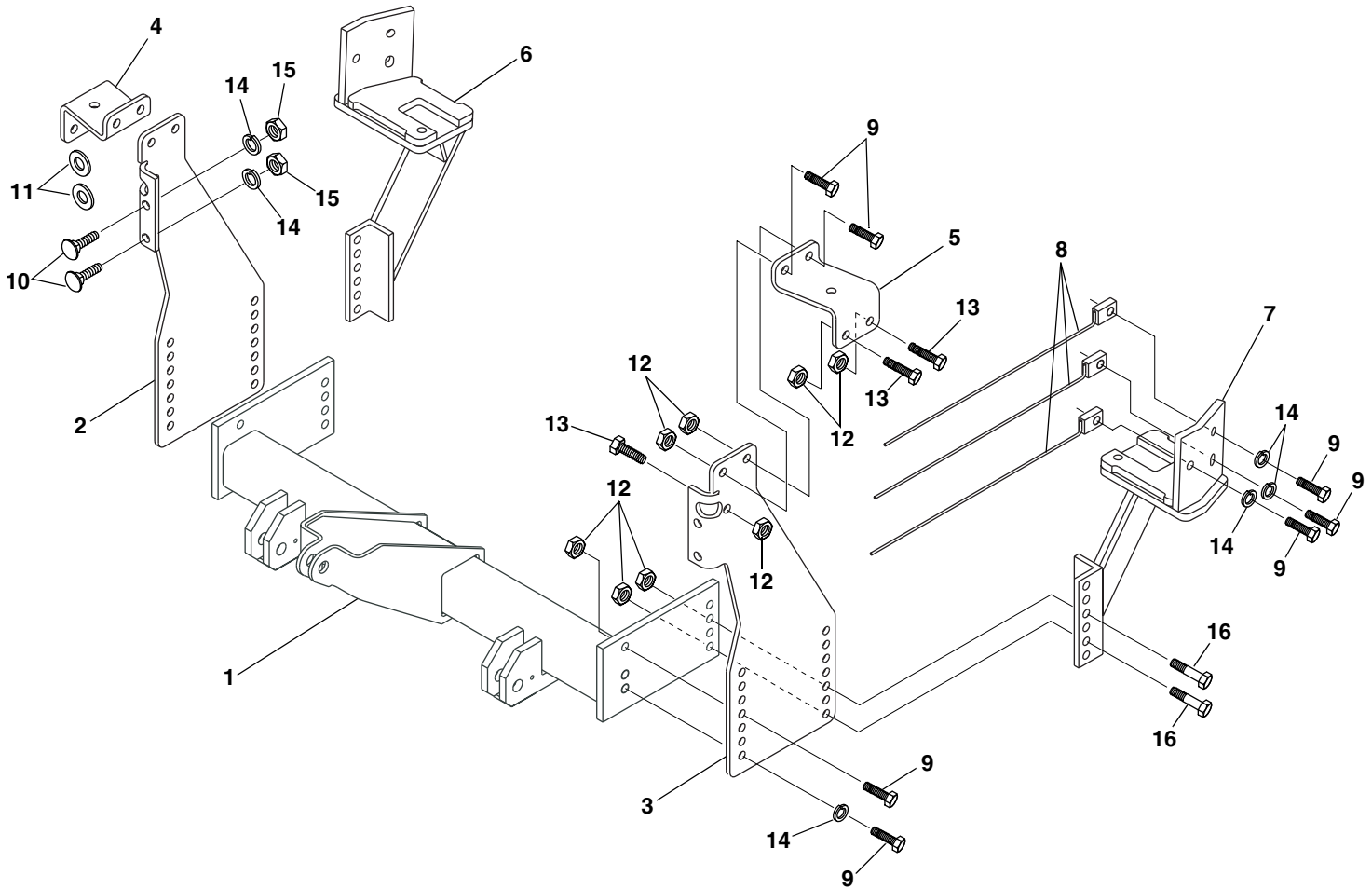

Note: It is recommended that LOCTITE®, or similar thread locking product, be used on ALL mounting hardware (i.e. Nuts, Cap Screws, Bolts, etc.).

ITEM	PART NO.	DESCRIPTION	QTY.
1	96103551	Assembly, Nose Piece	1
2	96103547	Plate, Front, R.H.	1
3	96103548	Plate, Front, L.H.	1
4	96103545	Bracket, Front, R.H.	1
5	96103546	Bracket, Front, L.H.	1
6	96103602	Assembly, Rear Mounting Bracket, RH	1
7	96103601	Assembly, Rear Mounting Bracket, LH	1
8	96103509	Assembly, Nut Plate	6
9	98009010	Cap Screw, Hex Head, 1/2"-13 x 1-1/2"	14
10	98009171	Carriage Bolt, 1/2"-13 x 1-1/2"	4
11	98009011	Washer, Flat, 1/2"	4
12	98009013	Nut, Hex Nylock, 1/2"-13	18
13	98100095	Cap Screw, Hex Head, 1/2"-13 x 1-3/4"	6
14	98009012	Washer, Lock, 1/2"	12
15	98009076	Nut, Hex, 1/2"-13	4
16	98100062	Cap Screw, Hex Head, 1/2"-13 x 2-1/4"	4

SNO-WAY® INTERNATIONAL, INC.



Hartford, WI 53027 USA
 Website: www.snoway.com
 ©2004 Sno-Way® International