

# **SNO-WAY**®

**SNOW & ICE CONTROL EQUIPMENT**

## **ASSEMBLY & INSTALLATION INSTRUCTIONS**

**VEHICLE MOUNT KIT 99100846  
AND  
VEHICLE CENTER MEMBER  
99100890**

**TO FIT**

**ALL NEW 2007 CHEVY TAHOE, AVALANCHE,  
SUNBURBAN AND SILVERADO PICKUP 4X4**

**ALL NEW 2007 GMC YUKON, YUKON XL, YUKON DENALI,  
YUKON XL DENALI AND 1500 SIERRA PICKUP 4X4**

**2007 CADILLAC ESCALADE 4X4**



Sno-Way® and EIS® are registered trademarks and Down Pressure™ is a trademark of Sno-Way International, Inc.

©2012 Sno-Way® International

97101310E



1. **THINK SAFETY, ALWAYS WEAR SAFETY GLASSES WHEN PERFORMING THE OPERATIONS PRESCRIBED IN THESE INSTRUCTIONS**
2. **READ ALL INSTRUCTIONS CAREFULLY BEFORE ATTEMPTING INSTALLATION**
3. **BEFORE BEGINNING WORK MAKE SURE TO SET PARKING BRAKE AND CHOCK WHEELS**



## MINIMUM VEHICLE RECOMMENDATIONS

Heavy Duty Alternator  
Heavy Duty Battery

*NOTE: On some vehicles it may be necessary to use a form of load booster to decrease the vehicle's front suspension sag with the snow plow in place. This can be accomplished with the use of supplementary air bags, booster springs, or similar load boosting devices. Since there are different load boosting devices available, it will up to the customer/end user to decide and purchase the product to suit the application, and not the responsibility of Sno-Way International, Inc.*

## ASSEMBLY TOOLS NEEDED

Drill Bits	1/4", 17/32"
Impact Sockets	7/16" – 1-3/8"
Metric Sockets	10 mm – 18 mm
Wrenches	7/16" – 1-3/8"
Metric Wrenches	10 mm – 18 mm
Torque Wrench	
Rat Tail Pry Bar	
Center Punch and Hammer	
**Rubber Bands**	

## INSTALLATION NOTES

1. **Unless otherwise specified, mount all Vehicle Mount Kit Components to vehicle before tightening any hardware.**
2. **It is recommended that LOCTITE®, or similar thread locking product, be used on ALL mounting hardware (i.e. Nuts, Cap Screws, Bolts, etc.).**
3. Vehicle should be parked on a level surface with a normal vehicle load on the FRONT suspension.
4. Items in parentheses () refer to quantity required for this step. Items in parentheses with a pound sign (#) indicate the part number as found in the parts list on the last page of this document.  
Example: (2) 1/2"-13 x 1-1/2" Cap Screws (#8).
5. It may be necessary to relocate license plate holder. Check state and local laws for placement, if needed.

Next use the rear hole in the Side Plate, LH that butts up against the bottom of the frame rail as a template, center punch and drill a 1/4" pilot hole then drill to 17/32.

Secure loosely the front hole using (1) Handle Bolt Weldment (#9) (1) 1/2" Flat Washer (#11) and (1) 1/2"-13 Nylock Nut (#8).

The rear drilled hole should be secured using (1) Handle Bolt Assembly (#6) and (1) 1/2" Flat Washer (#11) inserted through the front of the frame rail.

*NOTE: GREAT TIP: Use a rubber band to keep the washer from falling off when inserting into the frame.*

3. Install Side Plate, RH (#3) (Passengers Side):  
Installation is the same as step 2, but the two hook holes are both already in the outside of the frame rail on the RH side of the vehicle so you don't have to drill the hole into the side of the frame.  
Secure the rear side hole in the Side Plate, RH (#3) using (1) 1/2"-13 x 1-1/2" Cap Screw (#7) (1) 1/2" Flat Washer (#11) and (1) 1/2"-13 Nylock Nut (#8).  
Note: you still have to drill the on in the bottom of the frame rail.
4. Install Crossmember Rear Weldment (#5):  
First, install (2) 1/2" wide Flat Washers (#11) on each of the (3) remaining Handle Bolt Weldments (#6).  
Wrap a rubber band around each of them, so they stay in place when inserted into the frame rail. Next, align the three rear slots in the Crossmember Rear Weldment (#5) to the large holes in the frame rail.  
Secure to the truck frame by inserting the (3) Handle Bolt Weldments (with the large washers) into the large hole in the vertical section of the frame rail on the passenger side of the vehicle, and securing them with (3) 1/2" Flat Washers (#11) and (3) 1/2"-13 Nylock Nuts (#8). Now secure the Crossmember Rear Weldment (#5) to the Vehicle Center Member (#1) using (2) Spacer Plates (#4) (between the Crossmember Rear Weldment and the vehicle center lugs), (4) 1/2"-13 x 2" Cap Screws (#12) (in the top and bottom hole in the lugs),

## MOUNTING INSTRUCTIONS

1. Remove bumper and retain hardware for reinstallation in a later step. Next, remove the tow hooks and retain with hardware, for use if vehicle mount kit is ever removed.

*NOTE: Prior to notching the fascia, use the exploded view on the back page to orient the Side Plates LH and RH correctly.*

2. Install Side Plate, LH (#2) (Drivers Side):  
To the outside of the vehicle frame, align the front hole in the Side Plate, LH (#2) with the existing tow hook hole in the frame.  
Secure loosely using (1) 1/2"-13 x 1-1/2" Cap Screw (#7) (1) 1/2" Flat Washer (#11) and (1) 1/2"-13 Nylock Nut (#8).  
Next, using the hole next to the front hole as a template, center punch and drill a 1/4" pilot hole, then drill to 17/32" through just the outside of the frame rail.

(2) 1/2"-13 x 1-1/2" Cap Screws (in one of the middle holes), and (6) 1/2"-13 Nylock Nuts (#8).

**IMPORTANT: Height from the center of the lower Plow mounting holes on the Vehicle Mount Kit to the ground should be between 8" and 10" to insure proper operation.**

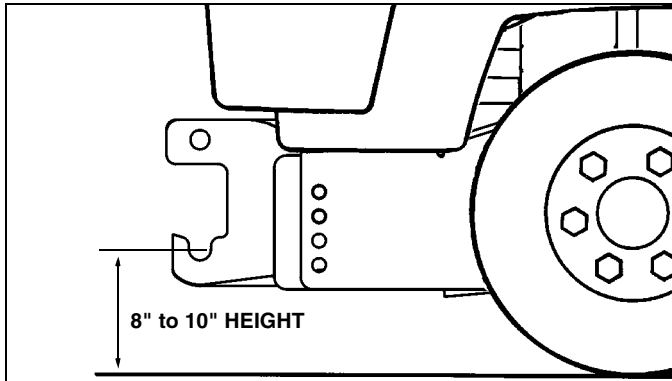

5. Using the torque specification chart provided, torque all cap screws.

TORQUE SPECIFICATIONS FOR STANDARD MACHINE HARDWARE					
Bolt Size	GR.2 Dry	GR.5 Dry	GR.8 Dry	Metric Size	GR.8.8 Dry
1/4"	66*	9	12	M8	17
5/16"	11	17	25	M10	35
3/8"	20	30	45	M12	60
7/16"	32	50	70	M14	95
1/2"	50	75	110	M16	155
9/16"	70	110	150		
5/8"	100	150	220		
3/4"	175	260	380		
7/8"	170	430	600		
1"	250	640	900		

Note: These torque values are to be used for all hardware. Unless otherwise specified, all torque values must meet this specification.  
 Note: All torque values are in Ft.-Lbs unless otherwise stated  
 Note: \*In-Lbs

**REMEMBER After 5 to 10 hours of snowplow usage, re-torque all Cap Screws!**

6. Reinstall bumper and all other items previously removed that can be reattached.

*NOTE: The splash guard will need major modifications if it is to be reinstalled with the vehicle mount kit attached.*

# PARTS LIST

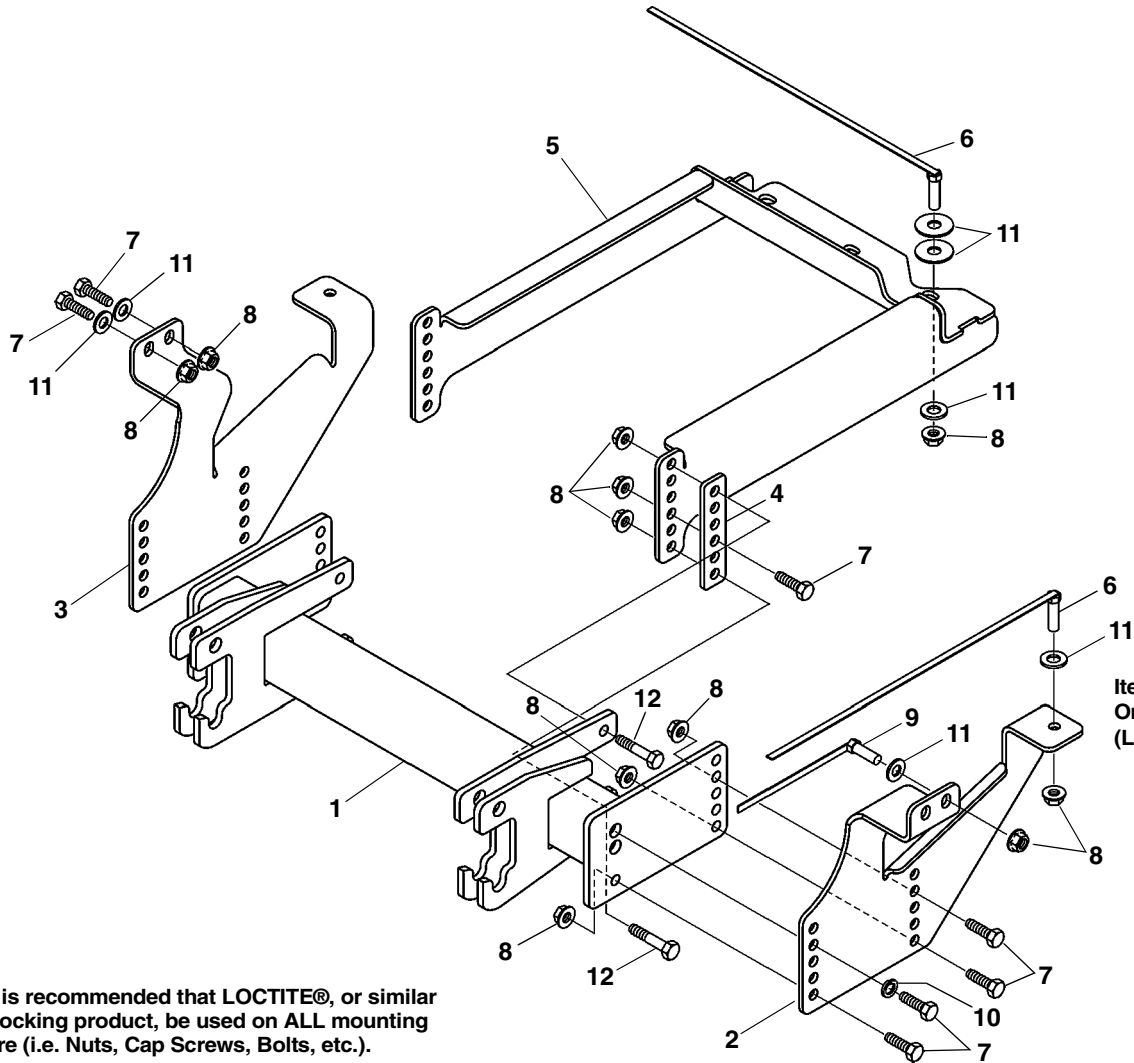

Item #9 Is Used  
On The Drivers  
(Left) Side Only

Note: It is recommended that LOCTITE®, or similar thread locking product, be used on ALL mounting hardware (i.e. Nuts, Cap Screws, Bolts, etc.).

ITEM	PART NO.	DESCRIPTION	QTY.
1	99100890	Vehicle Center Member .....	1
2		Plate, Side, LH .....	1
3		Plate, Side, RH .....	1
4		Spacer Plate.....	2
5		Crossmember Rear Weldment.....	1
6		Handle Bolt Weldment .....	5
7		Cap Screw, Hex Head, 1/2"-13 x 1-1/2" .....	13
8		Nut, Nylock, 1/2"-13 .....	21
9		Handle Bolt Weldment .....	1
10		Washer, Lock, 1/2" .....	2
11		Washer, Flat, A Wide .....	16
12		Cap Screw, Hex Head, 1/2"-13 x 2" .....	4
13	96109666	Kit, HDWE (Includes Items 7, 8, 10-12) (Not Shown) .....	1

SNO-WAY® INTERNATIONAL, INC.



Hartford, WI 53027 USA  
Website: [www.snoway.com](http://www.snoway.com)  
©2012 Sno-Way® International