



**Assembly
&
Installation Instructions**

**FOR
VEHICLE MOUNT KIT 99100866
USING
VEHICLE CENTER MEMBER 99100891**

**TO FIT
1980 - 1991 Ford F250-F350 4x4**



1. **THINK SAFETY, ALWAYS WEAR SAFETY GLASSES WHEN PERFORMING THE OPERATIONS PRESCRIBED IN THESE INSTRUCTIONS**
2. **READ ALL INSTRUCTIONS CAREFULLY BEFORE ATTEMPTING INSTALLATION**
3. **BEFORE BEGINNING WORK MAKE SURE TO SET PARKING BRAKE AND CHOCK WHEELS**



MINIMUM VEHICLE RECOMMENDATIONS

Heavy Duty Front Springs
 Heavy Duty Battery
 Heavy Duty Alternator
 Manufacturer's Snow Plow Package

NOTE: On some vehicles it may be necessary to use a form of load booster to decrease the vehicle's front suspension sag with snow plow in place. This can be accomplished with the use of supplementary air bags, booster springs, or similar load boosting devices. Since there are different load boosting devices available, it will be up to the customer/end user to decide and purchase the product to suit the application, and not the responsibility of Sno-Way International, Inc.

NOTE: On some vehicles, the anti-sway bar must be removed in order to install the Vehicle Mount Kit. Retain with hardware if the Vehicle Mount Kit is removed from the vehicle. It is important that the anti-sway bar be re-installed if the Vehicle Mount Kit is removed.

ASSEMBLY TOOLS NEEDED

Drill Bits 1/4", 17/32"
 Sockets 7/16" -- 1 1/8"
 Wrenches 7/16" -- 1-3/8"
 Torque Wrench
 Center Punch and Hammer
 Clamping Devices ("C", Bar, type device....)
 Rat Tail Pry Bar
 Hacksaw

INSTALLATION NOTES

1. **Unless otherwise specified, mount all Subframe Components to vehicle before tightening any hardware.**
2. **It is recommended that LOCTITE®, or similar thread locking product, be used on ALL mounting hardware (i.e. Nuts, Cap Screws, Bolts, etc.).**
3. Vehicle should be parked on a level surface with a normal vehicle load on the FRONT suspension.
4. Items in parentheses () refer to quantity required for this step. Items in parentheses with a pound sign (#) indicate the part number as found in the parts list on the last page of this document.
 Example: (2) 1/2"-13 x 2-1/4" Carriage Bolts (#8).
5. It may be necessary to relocate license plate holder. Check state and local laws for placement, if needed.

MOUNTING INSTRUCTIONS

- **Vehicles from 1980-1986**
1. Remove the front bumper from the vehicle.



WARNING

Beware of brake and fuel lines secured to inside wall of frame rails when drilling holes in vehicle frame!
FAILURE TO HEED CAN RESULT IN INJURY OR DEATH!

2. Mount (1) Front Crossmember Weldment (#2) over vehicle frame horns. Leave approximately a 1/4" gap between the top of the frame horn and the Front Crossmember Weldment. Clamp in place keeping the face of the Front Crossmember Weldment perpendicular to the ground. Using the side holes in the Front Crossmember Weldment as a template, drill (4) 1/4" holes, then 17/32" holes through the outer wall of the vehicle frame. Secure tightly using (4) 1/2" x 1-1/2" Hex Head Cap Screws (#10), (4) Flat Washers (#9), and (4) Nylock Nuts (#13).
 3. Reinstall the front bumper, using (4) 1/2" x 2-1/4" Carriage Bolts (#8), (4) Flat Washers (#9) and (4) Nylock Nuts (#13), placing (4) Spacer Tubes (#7) between the bumper and the frame.
- **Vehicles from 1987-1991**
1. Remove the front bumper from the vehicle.

2. Mount (1) Front Crossmember Weldment (#2) over the vehicle frame horns, aligning the mounting holes as close as possible to existing holes in the vehicle frame.
3. Raise and align the front bumper mounting bracket holes with the mounting holes of the Front Crossmember Weldment (#2). Keeping the front face of the Front Crossmember Weldment perpendicular to the ground, secure tightly using (4) 1/2" x 1-1/2" Hex Head Cap Screws (#10), (4) Flat Washers (#9), and (4) Nylock Nuts (#13).

• **Mounting instructions for all vehicles**

1. Attach (1) Vehicle Center Member (#1) to the Front Crossmember Weldment (#2) in the front set of vertical holes and secure using (6) 1/2" x 1-1/2" Hex Head Cap Screws (#10), (2) Nylock Nuts (#13) and (4) Lock Washers (#12).
2. Align the bottom holes of (1) Rear Mtg Weldment (#3 and #4) with the back set of vertical holes on the Vehicle Center Member. Secure with (4) 1/2" x 2-1/4" Hex Head Cap Screws (#11) and (4) 1/2" Nylock Nuts (#13). Clamp the Rear Mtg Weldments to the vehicle frame making sure the Weldments are tight with the bottom and sides of the vehicle frame.

3. Using the (8) holes in the Rear Mtg Weldments (#3) LH & (#4) RH as a template - center punch and drill (8) holes through the outer wall of the vehicle frame rails, by first using a 1/4" and then a 17/32" drill bit. Remove clamps and secure Weldments using (8) 1/2" x 1-1/2" Hex Head Cap Screws (#10) and (8) Lock Washers (#12), and inside the frame tubes using (1 set per side) Nut Plate Assembly (#5 LH & #6 RH). Wire handles should face to the front of the vehicle.
4. Using the Torque Specification Chart below, torque all bolts starting at the rear and working forward.

TORQUE SPECIFICATIONS FOR STANDARD MACHINE HARDWARE					
Bolt Size	GR.2 Dry	GR.5 Dry	GR.8 Dry	Metric Size	GR.8.8 Dry
1/4"	66*	9	12	M8	17
5/16"	11	17	25	M10	35
3/8"	20	30	45	M12	60
7/16"	32	50	70	M14	95
1/2"	50	75	110	M16	155
9/16"	70	110	150		
5/8"	100	150	220		
3/4"	175	260	380		
7/8"	170	430	600		
1"	250	640	900		

Note: These torque values are to be used for all hardware. Unless otherwise specified, all torque values must meet this specification.
 Note: All torque values are in Ft.-Lbs unless otherwise stated
 Note: *In-Lbs

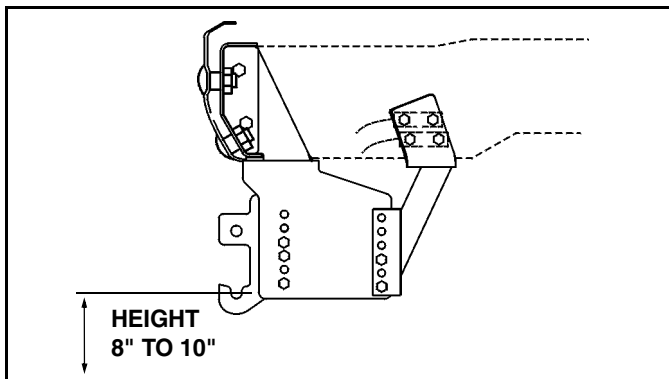
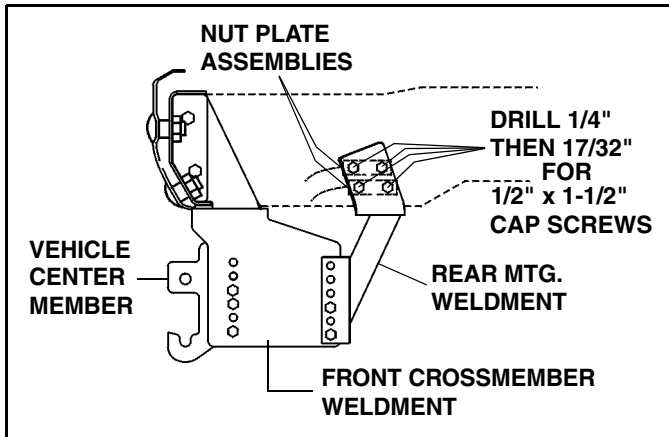

IMPORTANT: Height from the center of the lower Plow mounting holes on the Vehicle Mounting Kit to the ground should be between 8" and 10" to insure proper operation.

REMEMBER After 5 to 10 hours of snowplow usage, re-torque all Cap Screws!

PARTS LIST

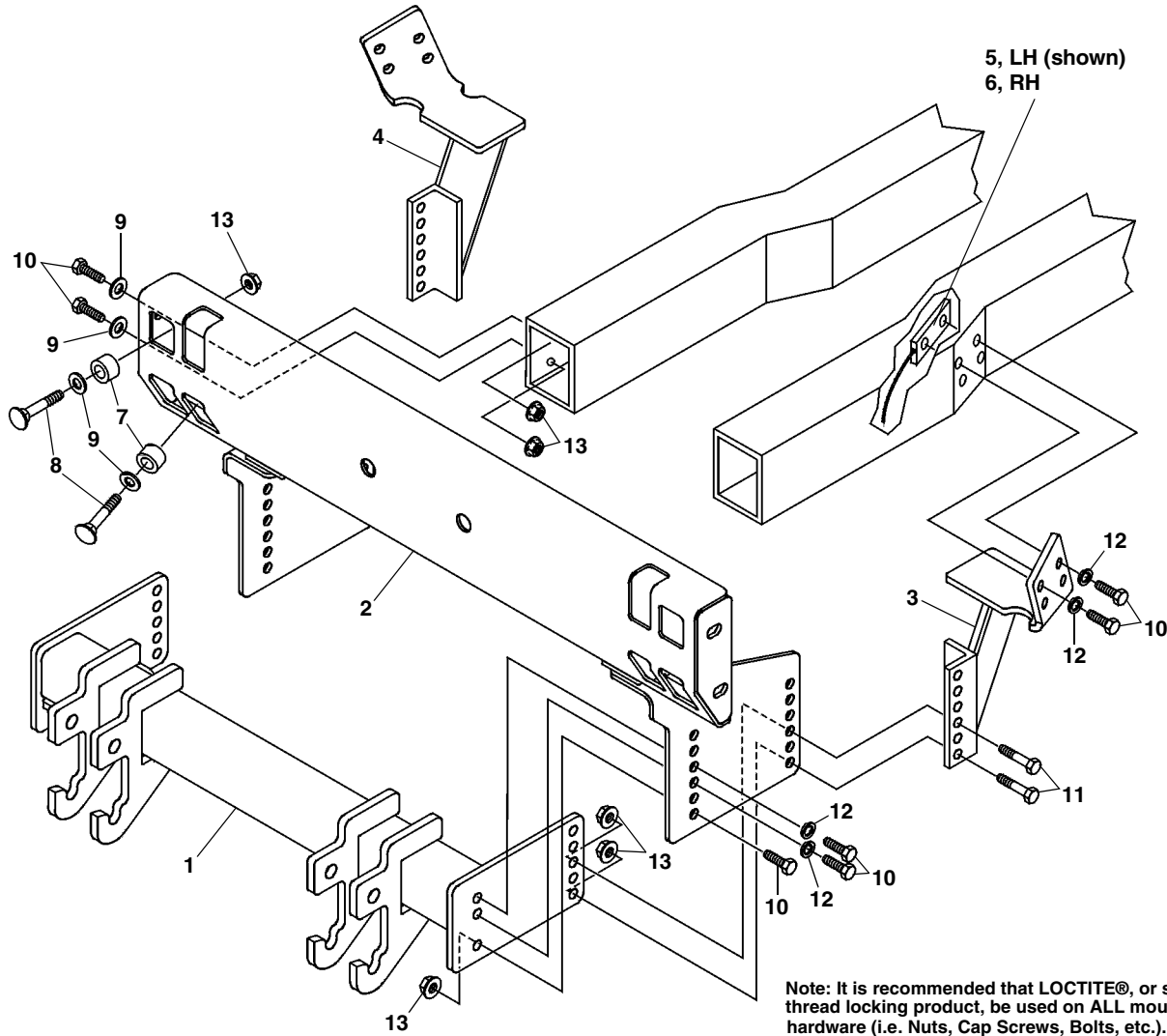

Note: It is recommended that LOCTITE®, or similar thread locking product, be used on ALL mounting hardware (i.e. Nuts, Cap Screws, Bolts, etc.).

ITEM	PART NO.	DESCRIPTION	QTY.
1	99100891	Vehicle Center Member (96108692)	1
2	96108826*	Front Crossmember Weldment	1
3	96108829*	Rear Mtg Weldment, LH	1
4	96108831*	Rear Mtg Weldment, RH	1
5	96100939*	Nut Plate Assembly, LH	2
6	96100938*	Nut Plate Assembly, RH	2
7	96101465*	Spacer Tube	4
8	98100067	Carriage Bolt, 1/2"-13 x 2-1/4"	4
9	98009011	Flat Washer, 1/2"	8
10	98009010	Hex Head Cap Screw, 1/2"-13 x 1-1/2"	18
11	98100062	Hex Head Cap Screw, 1/2"-13 x 2-1/4"	4
12	98009012	Lock Washer, 1/2"	12
13	98009013	Nylock Nut, 1/2"	14

* Not Available As a Service Part

SNO-WAY® INTERNATIONAL, INC.



Hartford, WI 53027 USA
 Website: www.snoway.com
 ©2006 Sno-Way® International

www.storksplows.com