

SNO-WAY®

SNOW & ICE CONTROL EQUIPMENT

ASSEMBLY & INSTALLATION INSTRUCTIONS

**VEHICLE MOUNT KIT 99100870
Using
Vehicle Center Mount 99100890**

TO FIT

1999 - 2006 1500 Silverado, Sierra, and Escalade 4x4

2007 1500 Silverado, Sierra, and Yukon (Classic) 4x4

2000 - 2006 1500 Tahoe, Suburban, and Yukon 4x4

2002 - 2006 1500 Avalanche 4x4

Sno-Way® and EIS® are registered trademarks and Down Pressure™ is a trademark of Sno-Way International, Inc.

©2018 Sno-Way® International

97101231G



1. **THINK SAFETY, ALWAYS WEAR SAFETY GLASSES WHEN PERFORMING THE OPERATIONS PRESCRIBED IN THESE INSTRUCTIONS**
2. **READ ALL INSTRUCTIONS CAREFULLY BEFORE ATTEMPTING INSTALLATION**
3. **BEFORE BEGINNING WORK MAKE SURE TO SET PARKING BRAKE AND CHOCK WHEELS**



MINIMUM VEHICLE RECOMMENDATIONS

Heavy Duty Alternator
 Heavy Duty Battery
 Manufacturers Snowplow Package

NOTE: On some vehicles it may be necessary to use a form of load booster to decrease the vehicle's front suspension sag with the snow plow in place. This can be accomplished with the use of supplementary air bags, booster springs, or similar load boosting devices. Since there are different load boosting devices available, it will up to the customer/end user to decide and purchase the product to suit the application, and not the responsibility of Sno-Way International, Inc.

ASSEMBLY TOOLS NEEDED

Drill Bits	1/4", 17/32", 21/32"
Impact Sockets	7/16" – 1-3/8"
Impact Sockets, Metric	10mm - 19mm
Wrenches	7/16" – 1-3/8"
Wrenches, Metric	10mm - 19mm
Torque Wrench	
Hacksaw	
Center Punch and Hammer	

INSTALLATION NOTES

1. **Unless otherwise specified, mount all Vehicle Mount Kit Components to vehicle before tightening any hardware.**
2. **It is recommended that LOCTITE®, or similar thread locking product, be used on ALL mounting hardware (i.e. Nuts, Cap Screws, Bolts, etc.).**
3. Vehicle should be parked on a level surface with a normal vehicle load on the FRONT suspension.
4. Items in parentheses () refer to quantity required for this step. Items in parentheses with a pound sign (#) indicate the part number as found in the parts list on the last page of this document.
 Example: (10) Washer, Lock, 1/2" (#8).
5. It maybe necessary to relocate license plate holder. Check state and local laws for placement, if applicable.

Nylock Nuts (#13). Next, align the bottom rear hole in each Side Plate with the Front Nut Plates (#5), inserted in the frame in step #4, and secure each with a 5/8" x 1-1/2" Cap Screw (#10) and 5/8" Lock Washer (#9).

Secure the front bottom hole using (on each side), 1/2"-13 x 1-1/2" Cap Screws (#12), 1/2" Lock Washers (#7), 1/2" Flat Washer (#15) and 1/2" Nylock Nut (#13).

NOTE: For most applications, the tow hooks will have to be left off the vehicle in order to mount the plow. In some cases the tow hooks can be re-installed. Re-install the tow hooks, if applicable, using the existing long bolts and nuts. Replace the smaller bottom mounting tow hook screws with (2) Metric Cap Screws M12-1.75 x 50 (#8) and (2) 1/2" Lock Washer (#7), provided.

MOUNTING INSTRUCTIONS

1. Remove the bumper and retain with hardware for re-installation in a later step.
2. Remove the tow hooks and retain with hardware for re-installation, if applicable. See *NOTE* after item #5.
3. Remove the splash shield from underneath the vehicle. Retain with hardware for re-installation in a later step.
4. Insert Front Nut Plates (#5) into the truck frame where the tow hooks were removed. Align the threaded holes over existing frame holes approximately 4" behind the bottom tow hook bolt holes.
5. Install the Side Plates, RH (#3) and LH (#4): Align the upper side mounting holes on the Side Plates with the outside existing tow hook mounting holes in the side of the frame rails. Insert a 1/2"-13 x 1-1/2" Cap Screw (#12), 1/2" Lock Washer (#7), and 1/2" Flat Washer (#15) through each Side Plate and frame rail, and secure with 1/2"

6. Enlarge 1/2" holes in the truck frame (approximately 15" apart) that aligns with the slotted holes in the Rear Crossmember Weldment (#2) with a 21/32" drill.
7. The Rear Crossmember Weldment can be mounted to the vehicle frame with (2) Cap Screws (#10) and (2) Rear Nut Plates (#6) with the Lock and Flat Washers provided. Make sure the Rear Crossmember Weldment is tight with the vehicle frame and parallel to ground.
8. Using the holes in the Rear Crossmember Weldment (that fits against the truck frame) as a template, center punch and drill thorough the vehicle frame rail with a 1/4" drill. Remove the Rear Crossmember Weldment and drill through the vehicle frame rail using 17/32" drill.
9. Attach the Rear Crossmember Weldment with (2) 5/8"-11 x 1-1/2" Cap Screws (#10), (2) 5/8" Lock Washers (#9) and (4) 5/8" Flat Washers (#11) into (2) Rear Nut Plates (#6) to the horizontal part of the vehicle frame. In the angled portion, insert (2) Handle Bolt Weldments (#16) and (2) 1/2" Flat Washers (#15) into the vehicle crossmember and then into the drilled holes, secure using (2) 1/2" Nylock Nuts (#13).

10. Assemble the Vehicle Center Member to the Side Plates, LH (#4) and RH (#3). Secure the front set of vertical holes with (4) 1/2"-13 x 1-1/2" Cap Screws (#12), (2) 1/2" Lock Washers (#7) into the threaded holes, and (2) 1/2" Nylock Nuts (#13). Secure the rear set of vertical holes with (4) 1/2"-13 x 1-3/4" Cap Screws and (4) 1/2" Nylock Nuts (#13).

NOTE: The top and bottom holes in the Spacer Plate (#18) must be secured to both holes in the center lug of the Vehicle Center Member using 1/2"-13 x 1-1/2" Cap Screws (#12) and 1/2" Nylock Nuts (#13). Depending on the position of the Vehicle Center Member, an additional 1/2"-13 x 1-1/2" Cap Screw (#12) and 1/2" Nylock Nut (#13) will be needed to ensure that the Spacer Plate (#18) is secured to the Rear Crossmember Weldment (#2) in two places.

11. Secure the Rear Crossmember Weldment to the Vehicle Center Member using (2) Spacer Plates (#18) (between the Rear Crossmember Weldment and the Vehicle Center Member center lugs), (6) 1/2"-13 x 1-1/2" Cap Screws (#12) and (6) 1/2" Nylock Nuts (#13).
12. Using the Torque Specification chart below, torque all bolts.
13. Re-install bumper and all other items previously removed.

TORQUE SPECIFICATIONS FOR STANDARD MACHINE HARDWARE					
Bolt Size	GR.2 Dry	GR.5 Dry	GR.8 Dry	Metric Size	GR.8.8 Dry
1/4"	66*	9	12	M8	17
5/16"	11	17	25	M10	35
3/8"	20	30	45	M12	60
7/16"	32	50	70	M14	95
1/2"	50	75	110	M16	155
9/16"	70	110	150		
5/8"	100	150	220		
3/4"	175	260	380		
7/8"	170	430	600		
1"	250	640	900		

Note: These torque values are to be used for all hardware. Unless otherwise specified, all torque values must meet this specification.
Note: All torque values are in Ft.-Lbs unless otherwise stated
Note: *In-Lbs

REMEMBER After 5 to 10 hours of snowplow usage, re-torque all Cap Screws!

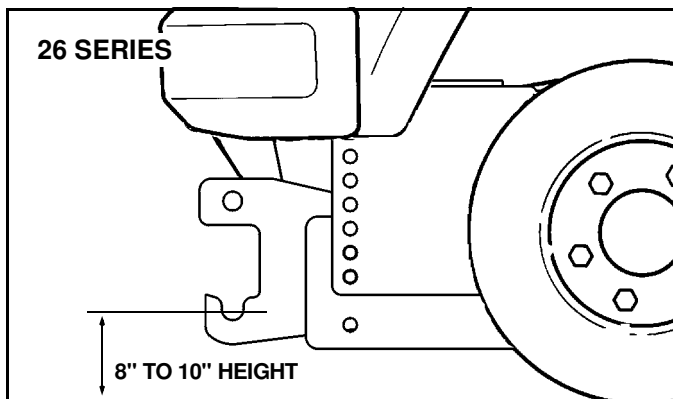

IMPORTANT: Height from the center of the lower Plow mounting holes on the Vehicle Mount Kit to the ground should be between 8" and 10" to ensure proper operation.

PARTS LIST

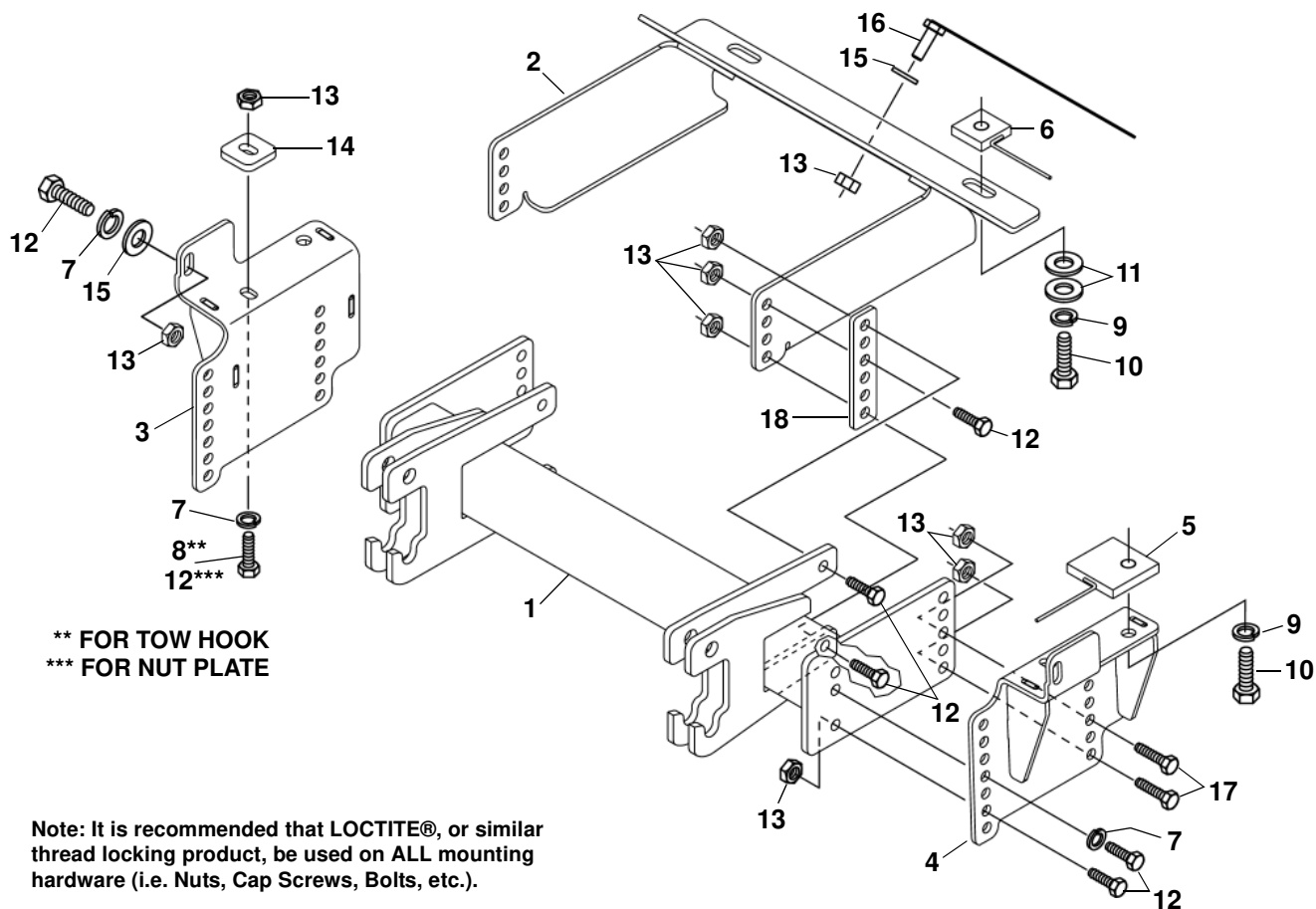

** FOR TOW HOOK
 *** FOR NUT PLATE

Note: It is recommended that LOCTITE®, or similar thread locking product, be used on ALL mounting hardware (i.e. Nuts, Cap Screws, Bolts, etc.).

ITEM	PART NO.	DESCRIPTION	QTY.
1	99100890	Vehicle Center Member.....	1
2		Rear Crossmember Weldment.....	1
3		Weldment, Side, RH.....	1
4		Weldment, Side, LH.....	1
5		Front Nut Plate.....	2
6		Rear Nut Plate.....	2
7		LW, 1/2".....	6
8		HHCS, M12-1.75 x 50mm.....	2
9		LW, 5/8".....	2
10		HHCS, 5/8"-11 x 1-1/2".....	4
11		PW, 5/8".....	4
12		HHCS, 1/2"-13 x 1-1/2".....	14
13		Nylock Nut, 1/2".....	18
14		Spacer.....	2
15		PW, 1/2".....	6
16		Handle Bolt Weldment.....	2
17		HHCS, 1/2"-13 x 1-3/4".....	4
18		Spacer Plate.....	2
19	96109109	Kit, HDWE (Includes Items 7-13, 15, 17) (Not Shown).....	1

SNO-WAY® INTERNATIONAL, INC.



Hartford, WI 53027 USA
 Website: www.snoway.com
 ©2018 Sno-Way® International