

# **SNO-WAY**®

**SNOW & ICE CONTROL EQUIPMENT**

## **ASSEMBLY & INSTALLATION INSTRUCTIONS**

**VEHICLE MOUNT KIT 99100871  
USING  
VEHICLE CENTER MEMBER  
FOR 26 SERIES: 99100890  
FOR 29 SERIES: 99100892**

**TO FIT  
2004 - 2008 FORD F150 4X4  
2004 - 2008 LINCOLN MARK LT 4X4**

Sno-Way®, Down Pressure® and EIS® are registered trademarks of Sno-Way International, Inc.  
ProControl™, MegaBlade™, V-Wing™, E-Z Switch™, Revolution™, MaxAdjust™, SpeedLock™, and QuickJack™  
are trademarks of Sno-Way International, Inc.

©2020 Sno-Way® International

97101221D



1. **THINK SAFETY, ALWAYS WEAR SAFETY GLASSES WHEN PERFORMING THE OPERATIONS PRESCRIBED IN THESE INSTRUCTIONS**
2. **READ ALL INSTRUCTIONS CAREFULLY BEFORE ATTEMPTING INSTALLATION**
3. **BEFORE BEGINNING WORK MAKE SURE TO SET PARKING BRAKE AND CHOCK WHEELS**



## MINIMUM VEHICLE RECOMMENDATIONS

Heavy Duty Alternator  
Heavy Duty Battery

*NOTE: On some vehicles it may be necessary to use a form of load booster to decrease the vehicle's front suspension sag with the snow plow in place. This can be accomplished with the use of supplementary air bags, booster springs, or similar load boosting devices. Since there are different load boosting devices available, it will up to the customer/end user to decide and purchase the product to suit the application, and not the responsibility of Sno-Way International, Inc.*

## ASSEMBLY TOOLS NEEDED

Drill Bits	1/4", 17/32"
Impact Sockets	7/16" – 1-3/8"
Impact Sockets, Metric	10mm - 18mm
Wrenches	7/16" – 1-3/8"
Wrenches, Metric	10mm - 18mm
Torque Wrench	
Rat Tail Pry Bar	
Center Punch and Hammer	

## INSTALLATION NOTES

1. **Unless otherwise specified, mount all Vehicle Mount Kit components to vehicle before tightening any hardware.**
2. **It is recommended that LOCTITE®, or similar thread locking product, be used on ALL mounting hardware (i.e. Nuts, Cap Screws, Bolts, etc.).**
3. Vehicle should be parked on a level surface with a normal vehicle load on the FRONT suspension.
4. Items in parentheses ( ) refer to quantity required for this step. Items in parentheses with a pound sign (#) indicate the part number as found in the parts list on the last page of this document.  
Example: (10) Washer, Lock, 1/2" (#8).
5. It maybe necessary to relocate license plate holder. Check state and local laws for placement, if needed.

## MOUNTING INSTRUCTIONS

1. Detach the rubber splash shield at the bottom edge of the bumper by removing the plastic fasteners. From the top of the bumper, remove the cap screws. Next remove the two hooks from the vehicle frame and retain the hardware for the Vehicle Mount Kit installation. Store the tow hooks separately fir reuse if the Vehicle Mount Kit is removed.
2. If equipped, remove the skid plate and save with hardware for re- installation if the Vehicle Mount Kit is removed. Also, if equipped with fog lights, disconnect the vehicle harness from the back of the fog lights.
3. Remove the four nuts (two per side) from the back of the bumper brackets. Remove the bumper now that all of the hardware is disconnected.
4. Install (1) Side Weldment, LH (#2): Align the tow hook bolts in the vehicle frame with the two front slots in the horizontal lip of the Side Weldment. Use the existing tow hook hardware to secure the Side Weldment

loosely to the bottom of the vehicle frame. Verify that the Side Weldment is tight against the vehicle frame by using a C-clamp to hold the front of the Side Weldment to the frame. The three slots on the horizontal lip of the Side Weldment align with the holes in the bottom of the vehicle frame rail. The hole in the front-most vertical tab in the Side Weldment aligns with the hole in the side of the vehicle frame rail. The rear-most vertical tab on the Side Weldment that has two holes in; the top hole should align with an existing hole in the side of the frame rail, but if not use the hole in the Side Weldment and the lower hole as a template and drill a 17/32" hole(s) through the outer wall of the frame rail. Insert (1) Spacer (#6) between the frame rail and the Side Weldment.

5. Secure the Side Weldment, LH (#2) as follows:
  - In the upper hole of the rear-most vertical tab, install (1) 1/2"-13 x 1-1/2" Cap Screw (#7) with (1) 1/2" Lock Washer (#8) into (1) Nut Plate Weldment (#13) that is inserted into the frame rail.
  - In the lower drilled hole on the same tab, install (1) 1/2"-13 x 1-1/2" Cap Screw (#7) with (1) 1/2" Lock Washer (#8) into (1) Nut Plate Weldment (#4) that is inserted into the frame rail.
  - In the front-most tab with the one hole, install (1) 1/2"-13 x 1-1/2" Cap Screw (#7) with (1) 1/2" Lock Washer (#8) into (1) Nut Plate Weldment (#5) that is inserted into the frame rail.
  - In the rear-most slot in the horizontal lip, install (1) 1/2"-13 x 1-1/2" Cap Screw (#7) with (1) 1/2" Lock Washer (#8) into (1) Nut Plate Weldment (#4) that is inserted into the frame rail.
6. Repeat Step #5 to install (1) Side Weldment, RH (#5).
7. a. **For 26 applications only:** Attach the Vehicle Center Member (#1A) to the Side Weldments, LH (#2) and RH (#3). Insert (4) Spacers (#12), 2 per side, as shown on the Part List on page 3. Secure using (8) 1/2"-13 x 1-3/4" Cap Screws (#11), (2) 1/2" Lock Washers (#8) in the threaded holes and (6) 1/2" Nylock Nuts (#9).

b. **For 29 applications only:** Attach the Vehicle Center Member (#1B) to the Side Weldments, LH (#2) and RH (#3). Insert (4) Spacers (#12), 2 per side, as shown on the Part List on page 3. Secure using (8) 1/2"-13 x 1-3/4" Cap Screws (#11), (2) 1/2" Lock Washers (#8) in the threaded holes and (6) 1/2" Nylock Nuts (#9).

8. With all the components now in place, tighten all hardware. Using the Toque Specification Chart provided, toque all Cap Screws.
9. Reinstall the bumper. Reconnect the fog lamp harness connectors if so equipped. **The bumper will have to be cut (notched) to achieve the desired Vehicle Mount Kit height requirement.**

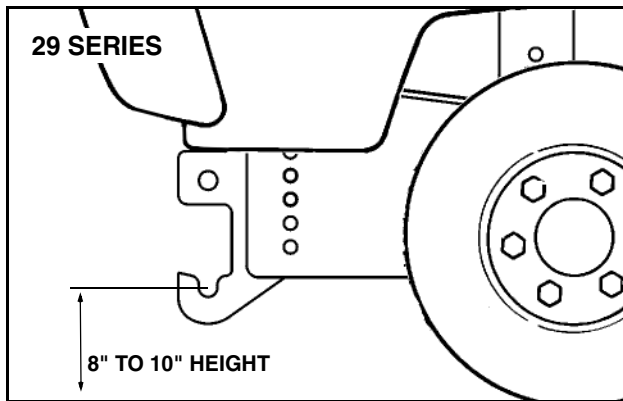
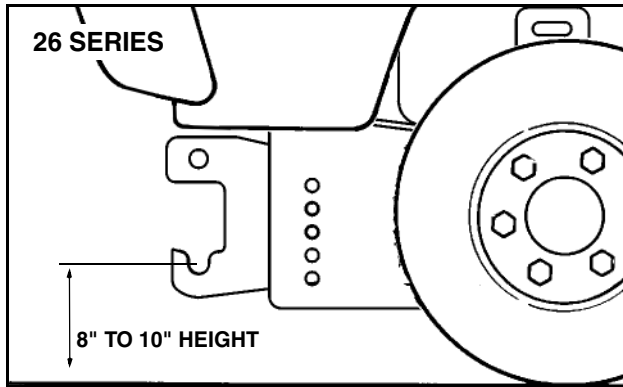

**IMPORTANT:** Height from the center of the lower plow mounting holes on the Vehicle Mount Kit to the ground should be between 8" and 10" to insure proper operation.

**TORQUE SPECIFICATIONS FOR STANDARD MACHINE HARDWARE**

Bolt Size	GR.2 Dry	GR.5 Dry	GR.8 Dry	Metric Size	GR.8.8 Dry
1/4"	66*	9	12	M8	17
5/16"	11	17	25	M10	35
3/8"	20	30	45	M12	60
7/16"	32	50	70	M14	95
1/2"	50	75	110	M16	155
9/16"	70	110	150		
5/8"	100	150	220		
3/4"	175	260	380		
7/8"	170	430	600		
1"	250	640	900		

Note: These torque values are to be used for all hardware. Unless otherwise specified, all torque values must meet this specification.  
 Note: All torque values are in Ft.-Lbs unless otherwise stated  
 Note: \*In-Lbs

**REMEMBER** After 5 to 10 hours of snowplow usage, re-torque all Cap Screws!

# PARTS LIST

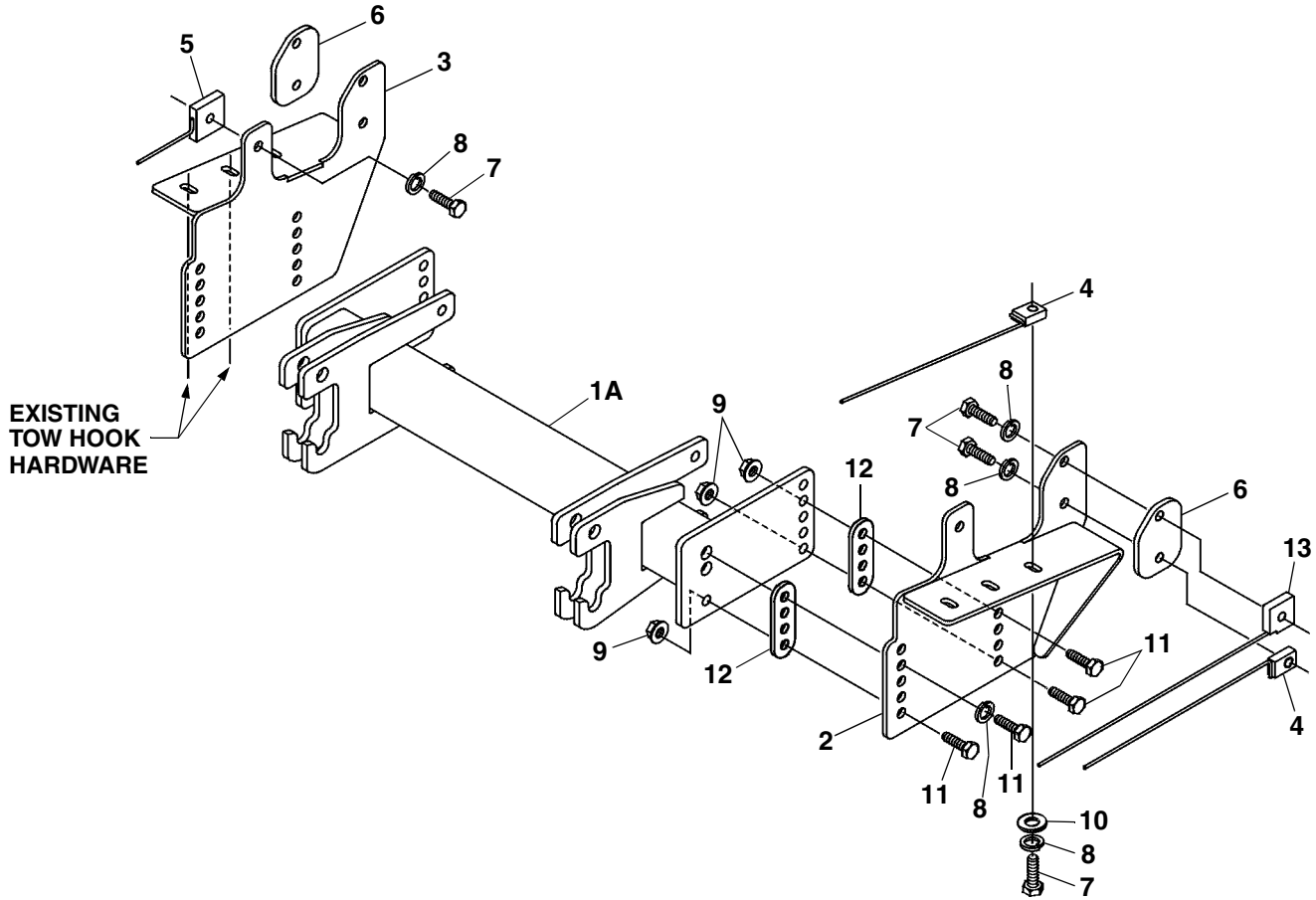

Note: It is recommended that LOCTITE®, or similar thread locking product, be used on ALL mounting hardware (i.e. Nuts, Cap Screws, Bolts, etc.).

ITEM	PART NO.	DESCRIPTION	QTY.
1	99100890	Vehicle Center Mount, 26 Series .....	1
2		Side Weldment, LH .....	1
3		Side Weldment, RH.....	1
4		Nut Plate Weldment .....	4
5		Nut Plate Weldment .....	2
6		Spacer .....	2
7		HHCS, 1/2"-13 x 1-1/2".....	8
8		LW, 1/2" .....	10
9		LN, 1/2".....	6
10		PW, 1/2".....	2
11		HHCS, 1/2"-13 x 1-3/4".....	8
12		Spacer, VCM, 3/8".....	4
13		Nut Plate Weldment .....	2
14	96109011	Kit, HDWE (Not Shown) (Includes Items 4-11) .....	1

SNO-WAY® INTERNATIONAL, INC.



Hartford, WI 53027 USA  
 Website: [www.snoway.com](http://www.snoway.com)  
 ©2020 Sno-Way® International