



**Assembly
&
Installation Instructions**

**FOR
VEHICLE MOUNT KIT 99100878
USING
FOR 1500 MODELS: VEHICLE CENTER MEMBER 99100890
FOR 2500 AND 3500 MODELS: VEHICLE CENTER MEMBER
99100892**

**TO FIT
1988 - 2000 CHEVROLET and GMC WT 1500, 2500 and 3500 PICKUP 4x4
1992 - 1999 CHEVROLET and GMC 1500 BLAZER,
1500 and 2500 SUBURBAN 4x4
1992 - 1999 GMC 1500 YUKON / DENALI 4x4**

©2006 Sno-Way® International

97101230A



1. **THINK SAFETY, ALWAYS WEAR SAFETY GLASSES WHEN PERFORMING THE OPERATIONS PRESCRIBED IN THESE INSTRUCTIONS**
2. **READ ALL INSTRUCTIONS CAREFULLY BEFORE ATTEMPTING INSTALLATION**
3. **BEFORE BEGINNING WORK MAKE SURE TO SET PARKING BRAKE AND CHOCK WHEELS**



MINIMUM VEHICLE RECOMMENDATIONS

Heavy Duty Alternator Heavy Duty Torsion Bars
 Heavy Duty Battery
 Manufacturers Snow Plow Package

ASSEMBLY TOOLS NEEDED

Drill Bits 21/32"
 Sockets 7/16" – 1-1/8"
 Wrenches 7/16" – 1-1/8"
 Torque Wrench
 Center Punch and Hammer
 Hacksaw

NOTE: On some vehicles it may be necessary to use a form of load booster to decrease the vehicle's front suspension sag with the snow plow in place. This can be accomplished with the use of supplementary air bags, booster springs, or similar load boosting devices. Since there are different load boosting devices available, it will up to the customer/end user to decide and purchase the product to suit the application, and not the responsibility of Sno-Way International, Inc.

INSTALLATION NOTES

1. **Unless otherwise specified, mount all Vehicle Mount Kit Components to vehicle before tightening any hardware.**
2. **It is recommended that LOCTITE®, or similar thread locking product, be used on ALL mounting hardware (i.e. Nuts, Cap Screws, Bolts, etc.).**
3. Vehicle should be parked on a level surface with a normal vehicle load on the FRONT suspension.
4. Items in parentheses () refer to quantity required for this step. Items in parentheses with a pound sign (#) indicate the part number as found in the parts list on the last page of this document.
 Example: (2) 5/8" - 11 x 2" Cap Screws (#10).
5. It maybe necessary to relocate license plate holder. Check state and local laws for placement, if applicable.

MOUNTING INSTRUCTIONS

1. Remove the air dam from the front of the vehicle. (Retain with hardware for future use).
2. Remove front bumper and tow hooks. Retain for re-installation.
3. Remove the four existing bolts holding the skid plate, retain hardware and remove corners for clearance. Retain for re-installation in Step 6.

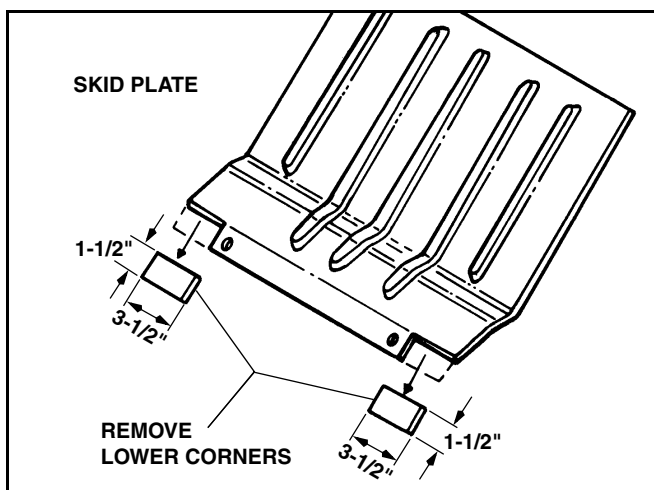

4. Install the Front Mtg Weldment, LH (#2) under the front frame rail of the vehicle, with the upper bracket flange at the outside of the frame rail. Install (3) M14-2.00 x 50mm Cap Screws (#14) and (3) M14 Lock Washers (#15) through the Front Mtg Weldment, LH, into existing holes in the side of the frame rail. Next insert (1) Nut Plate (#5) into the frame. Position a tow hook below the Front Mtg Weldment and secure with (2) 1/2"-13 x 3" Cap Screws (#16), (2) 1/2" Lock Washers (#8), (2) 1/2" Flat Washers (#10) through the slots in the bottom of the Front Mtg Weldment, LH.
5. Repeat Step 4 to install the Front Bracket Assembly, RH (#3).

NOTE: If the holes for mounting the Crossmember Rear Weldment are not present in the vehicle frame, the following will be necessary:

The Vehicle Center Member will have to be assembled to the Front Mtg Weldments, LH and RH. Then the Crossmember Rear Weldment must be assembled to the Vehicle Center Member. Finally, two 21/32 holes will have to be drilled through the frame on the horizontal portion of the frame. Using the two holes in the angled portion of the Crossmember Rear Weldment as a template, drill 17/32" through the angled portion of the frame rail.

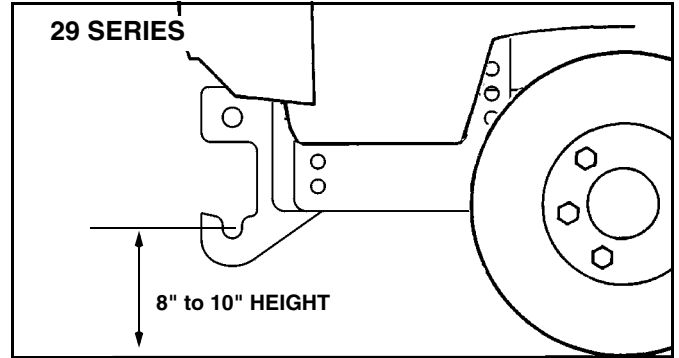
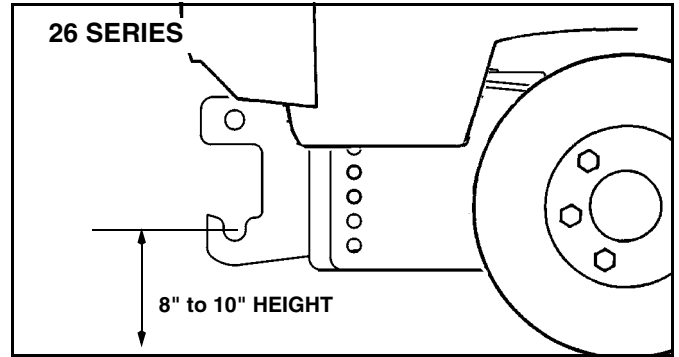
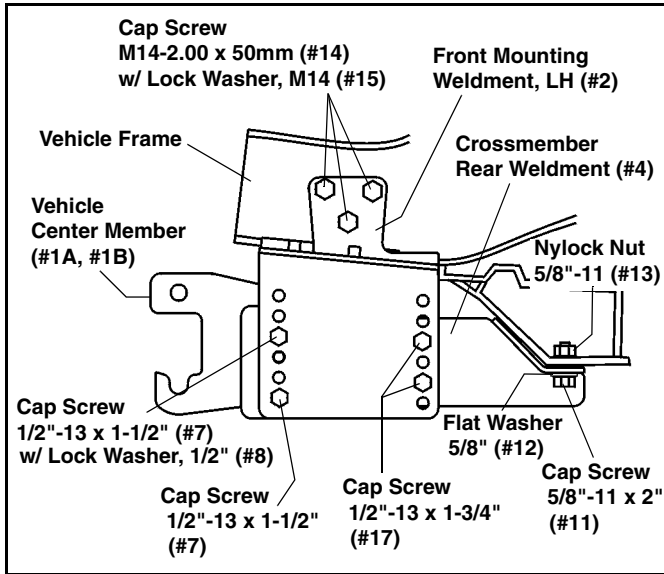

IMPORTANT: Height from the center of the lower pin slots on the Vehicle Mount Kit to the ground should be between 8" and 10" to ensure proper operation. On some vehicles, it may be necessary to use a form of load booster (See NOTE on page 1, Minimum Vehicle Recommendations).

6. Position the Crossmember Rear Weldment (#4) on the vehicle frame crossmember, and attach through the two outer mounting holes with (2) 5/8"-11 x 2" Cap Screws (#11), (2) 5/8" Flat Washers (#12), and (2) 5/8" Nylock Nuts (#13). Through the drilled 17/32" holes, insert (2) Handle Bolt Weldments (#6), with (2) 1/2" Flat Washers (#10), and secure with (2) 1/2" Nylock Nuts (#9).

7. Install the Vehicle Center Member (#1); Secure to the Front Mtg Weldments, LH (#2) and RH (#3) in the front set of vehicle holes, using (4) 1/2"-13 x 1-1/2" Cap Screws (#7), (2) 1/2" Lock Washers (#8) in the threaded holes, and (2) 1/2" Nylock Nuts (#9). Assemble the Vehicle Center member between the Front Mtg Weldments, LH (#2) and RH (#3), and the Crossmember Rear Weldment (#4), in the rear set of vertical holes. Secure using (4) 1/2"-13 x 1-3/4" Cap Screws (#17) and (4) 1/2" Nylock Nuts (#9).

8. Using the Torque Specification Chart provided, torque all Cap Screws starting at the rear and working forward.

REMEMBER After 5 to 10 hours of snowplow usage, re-torque all cap screws.

TORQUE SPECIFICATIONS FOR STANDARD MACHINE HARDWARE					
Bolt Size	GR.2 Dry	GR.5 Dry	GR.8 Dry	Metric Size	GR.8.8 Dry
1/4"	66*	9	12	M8	17
5/16"	11	17	25	M10	35
3/8"	20	30	45	M12	60
7/16"	32	50	70	M14	95
1/2"	50	75	110	M16	155
9/16"	70	110	150		
5/8"	100	150	220		
3/4"	175	260	380		
7/8"	170	430	600		
1"	250	640	900		

These torque values are to be used for all hardware. Unless otherwise specified, all torque values must meet this specification.
All torque values are in Ft.-Lbs unless otherwise stated
*In-Lbs

PARTS LIST

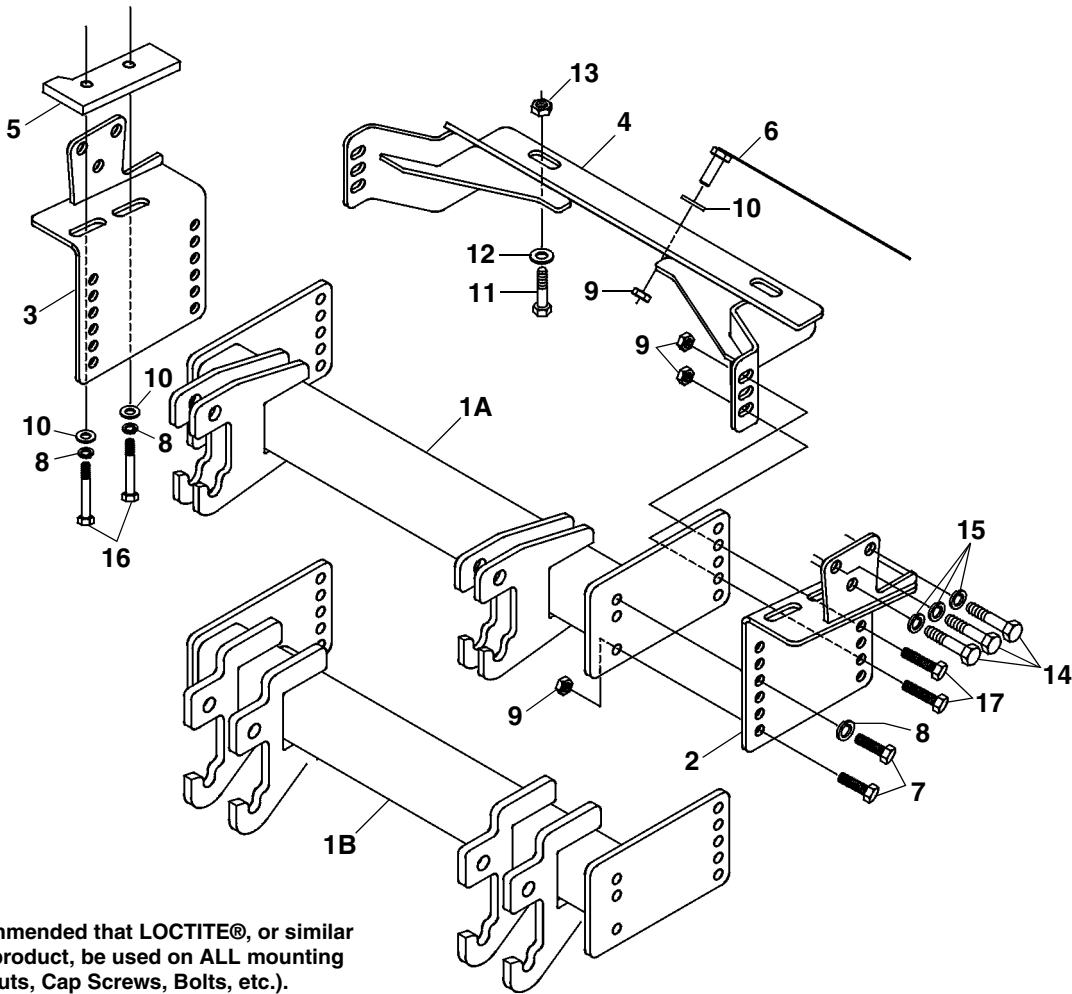

Note: It is recommended that LOCTITE®, or similar thread locking product, be used on ALL mounting hardware (i.e. Nuts, Cap Screws, Bolts, etc.).

ITEM	PART NO.	DESCRIPTION	QTY.
1A	99100890	Vehicle Center Member (991008560)	1
1B	99100892	Vehicle Center Member (991008919)	1
2	96108924*	Front Mtg Weldment, LH	1
3	96108925*	Front Mtg Weldment, RH.....	1
4	96108929*	Crossmember Rear Weldment.....	1
5	96101691*	Nut Plate.....	2
6	96108555*	Handle Bolt Weldment.....	2
7	98009010	Cap Screw, Hex Head, 1/2"-13 x 1-1/2"	4
8	98009012	Washer, Lock, 1/2"	6
9	98009013	Nut, Nylock, 1/2"	8
10	98009011	Washer, Flat, 1/2"	6
11	98009041	Cap Screw, Hex Head, 5/8"-11 x 2"	2
12	98009039	Washer, Flat, 5/8"	2
13	98009038	Nut, Nylock, 5/8"	2
14	98100305	Cap Screw, Hex Head, M14-2.00 x 50mm	6
15	98100306	Washer, Lock, M14.....	6
16	98009017	Cap Screw, Hex Head, 1/2"-13 x 3"	4
17	98100095	Cap Screw, Hex Head, 1/2"-13 x 1-3/4"	4

* Not Available As a Service Part

SNO-WAY® INTERNATIONAL, INC.



Hartford, WI 53027 USA
 Website: www.snoway.com
 ©2006 Sno-Way® International