

SNO-WAY[®]

SNOW & ICE CONTROL EQUIPMENT

Assembly & Installation Instructions

**FOR
VEHICLE MOUNT KIT 99100880
USING
VEHICLE CENTER MEMBER 99100890**

**TO FIT
2000 - 2004 DODGE DAKOTA 4X4
2000 - 2003 DODGE DURANGO 4X4**

26 SERIES PLOW ONLY



1. **THINK SAFETY, ALWAYS WEAR SAFETY GLASSES WHEN PERFORMING THE OPERATIONS PRESCRIBED IN THESE INSTRUCTIONS**
2. **READ ALL INSTRUCTIONS CAREFULLY BEFORE ATTEMPTING INSTALLATION**
3. **BEFORE BEGINNING WORK MAKE SURE TO SET PARKING BRAKE AND CHOCK WHEELS**



MINIMUM VEHICLE RECOMMENDATIONS

Heavy Duty Alternator

Heavy Duty Battery

NOTE: On some vehicles it may be necessary to use a form of load booster to decrease the vehicle's front suspension sag with the snow plow in place. This can be accomplished with the use of supplementary air bags, booster springs, or similar load boosting devices. Since there are different load boosting devices available, it will up to the customer/end user to decide and purchase the product to suit the application, and not the responsibility of Sno-Way International, Inc.

ASSEMBLY TOOLS NEEDED

Impact Sockets

7/16" – 1-3/8"

Metric Sockets

10 – 19 mm

Wrenches

7/16" – 1-3/8"

Metric Wrenches

10 – 19 mm

Torque Wrench

Clamps

INSTALLATION NOTES

1. **Unless otherwise specified, mount all Vehicle Mount Kit Components to vehicle before tightening any hardware.**
2. **It is recommended that LOCTITE®, or similar thread locking product, be used on ALL mounting hardware (i.e. Nuts, Cap Screws, Bolts, etc.).**
3. Vehicle should be parked on a level surface with a normal vehicle load on the FRONT suspension.
4. Items in parentheses () refer to quantity required for this step. Items in parentheses with a pound sign (#) indicate the part number as found in the parts list on the last page of this document.
Example: (2) 5/8" x 1-1/2" Cap Screws (#7).
5. It may be necessary to relocate license plate holder. Check state and local laws for placement, if needed.

MOUNTING INSTRUCTIONS

1. If the vehicle is equipped with bumper lamps, disconnect the light harness before bumper removal.
2. Remove four bumper bolts from the top of bumper brackets located under the vehicle hood. Remove remaining bumper bracket bolts on the side of the vehicle frame. Remove bumper and retain with hardware for later installation.
3. Remove the snap fasteners and air deflector.
4. Remove the four metric nuts on the metric bolts located inside the box frame horn on either side of the vehicle. Retain the nuts in the event that the Vehicle Mount Kit is removed from the vehicle.

NOTE: Only the four M12 serrated button head bolts at the front of each of the frame horns need to be driven out. The bolts near the back of the radiator can remain in place.

5. Clamp the bumper brackets to the frame and drive out the front four metric bolts from both sides. Remove

the clamp and retain the bolts in the event the Vehicle Mount Kit is removed from the vehicle.

6. Install Front Mtg Weldment, LH (#2):
Align the front most holes with the vertical holes (some models have slots) in the bumper bracket (the ones that were just driven out). Sandwich the bumper bracket between the Front Mounting Assembly and the vehicle frame. Secure from the engine side with (2) 7/16"-14 x 1 1/2" Cap Screws (#11), (4) 7/16" Lock Washers (#13) (2 on each side of the frame rail) (2) 1/2" Flat Washers (#10) (on the inside of the frame rail) and (2) 7/16" Nylock Nuts (#12). Secure the holes to the outside of the frame rail using (2) M12-1.75 x 40mm Cap Screws (#16), (2) 1/2" Flat Washers (#10) (if there is a space between the Front Mounting Bracket and the vehicle frame) and then into the threaded hole in the frame rail.

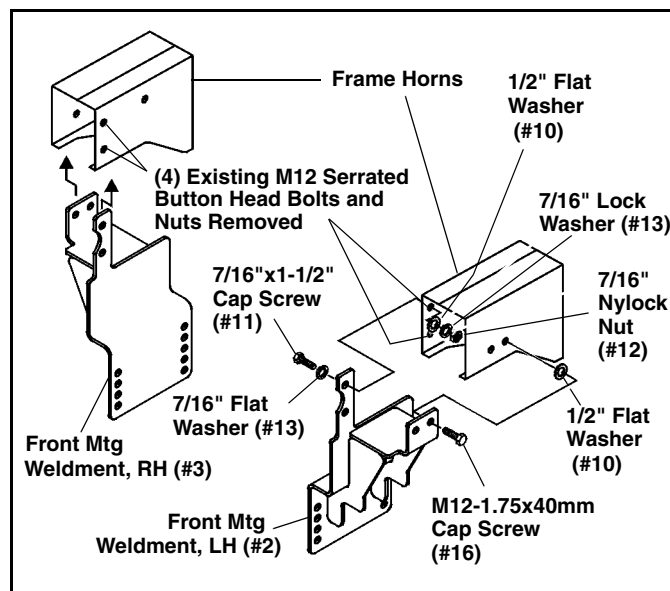
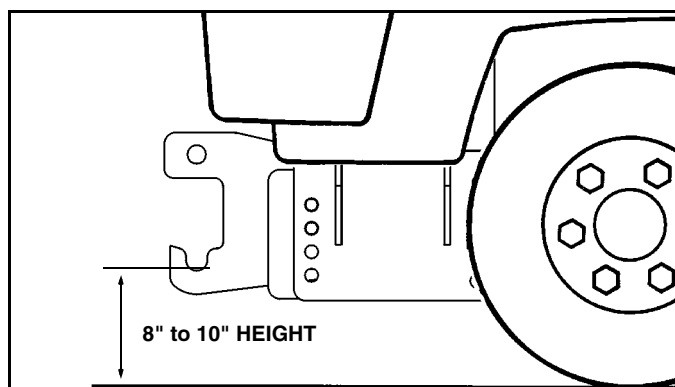

Figure 1

7. Repeat step #6 to install Front Mtg Weldment, RH (#3).

8. Remove the plastic hole covers from each side of the vehicle frame crossmember to provide access for installing the Nut Plate Assemblies (#5).
9. Place the Crossmember Rear Weldment (#4) in position against the vehicle frame crossmember. Insert (2) 5/8"-11 x 2" Hex Head Cap Screws (#6) with (2) 5/8" Lock Washers (#7) through the holes in the slanted surface of the vehicle crossmember and align with the (2) Nut Plate Assemblies (#5) inside the vehicle frame. Secure the top holes using (2) 1/2"-13 x 1-1/2" Hex Head Cap Screws (#8), (2) 1/2" Flat Washers (#10) and (2) 1/2" Nylock Nuts (#9).
10. Install Vehicle Center Member (#1). Secure to the Front Mtg Weldments, LH (#2) and RH (#3) in the front set of vertical holes using (4) 1/2"-13 x 1-1/2" Cap Screws (#8), (2) 1/2" Lock Washers (#14) in the threaded holes, and (2) 1/2" Nylock Nuts (#9). Secure the Vehicle Center Member (#1) between the Crossmember Rear Weldment (#4) and the Front Mtg Weldments, LH (#2) and RH (#3) in the rear set of vertical holes using (4) 1/2"-13 x 1-3/4" Cap Screws (#15) and (4) 1/2" Nylock Nuts (#9).



11. Using the torque specification chart given, torque all bolts.

TORQUE SPECIFICATIONS FOR STANDARD MACHINE HARDWARE					
Bolt Size	GR.2 Dry	GR.5 Dry	GR.8 Dry	Metric Size	GR.8.8 Dry
1/4"	66*	9	12	M8	17
5/16"	11	17	25	M10	35
3/8"	20	30	45	M12	60
7/16"	32	50	70	M14	95
1/2"	50	75	110	M16	155
9/16"	70	110	150		
5/8"	100	150	220		
3/4"	175	260	380		
7/8"	170	430	600		
1"	250	640	900		

Note: These torque values are to be used for all hardware. Unless otherwise specified, all torque values must meet this specification.
 Note: All torque values are in Ft.-Lbs unless otherwise stated
 Note: *In-Lbs

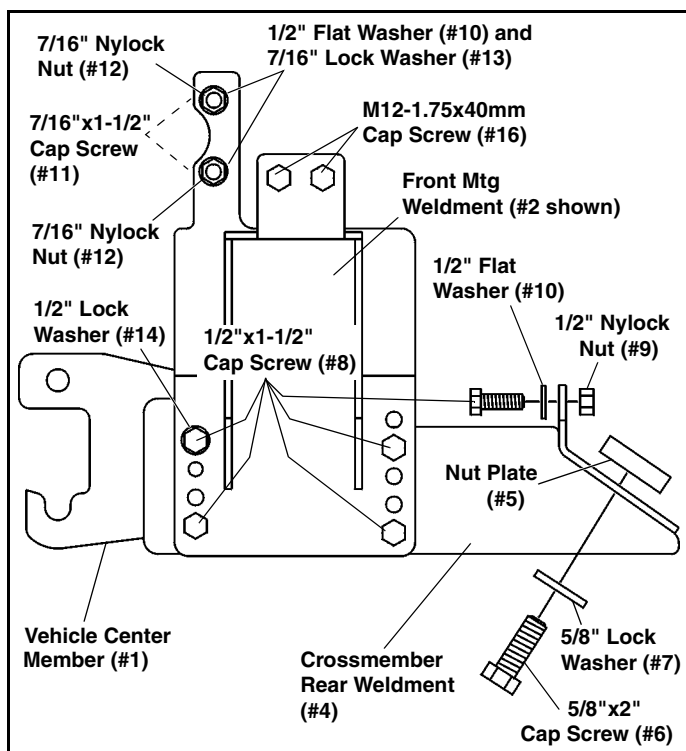

Figure 2

IMPORTANT: Height from the center of the lower Plow mounting holes on the Vehicle Mount Kit to the ground should be between 8" and 10" to insure proper operation.

REMEMBER After 5 to 10 hours of snowplow usage, re-torque all Cap Screws!

12. Re-install the front bumper onto the vehicle. Reinstall the light harness for the bumper lamps, if so equipped.

PARTS LIST

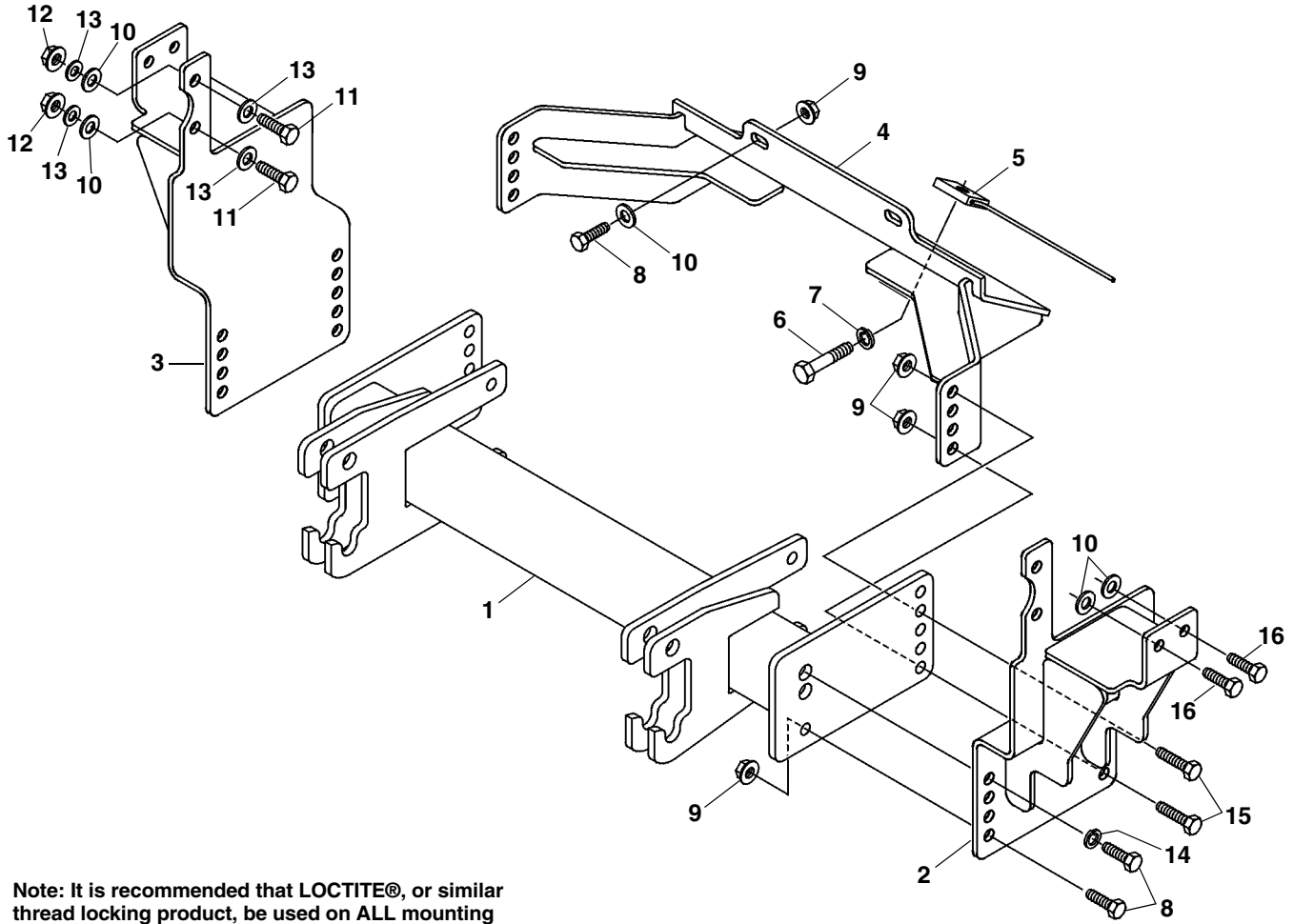

Note: It is recommended that LOCTITE®, or similar thread locking product, be used on ALL mounting hardware (i.e. Nuts, Cap Screws, Bolts, etc.).

ITEM	PART NO.	DESCRIPTION	QTY.
1	99100890	Vehicle Center Member (96108560)	1
2	96108906*	Front Mtg Weldment, LH	1
3	96108907*	Front Mtg Weldment, RH.....	1
4	96108908*	Crossmember Rear Weldment.....	1
5	96103557*	Nut Plate Assembly	2
6	98009041	Hex Head Cap Screw, 5/8"-11 x 2".....	2
7	98009062	Lock Washer, 5/8"	2
8	98009010	Hex Head Cap Screw, 1/2"-13 x 1-1/2"	6
9	98009013	Nylock Nut, 1/2"-13.....	8
10	98009011	Flat Washer, 1/2"	10
11	98009048	Hex Head Cap Screw, 7/16"-14 x 1-1/2"	4
12	98009050	Nylock Nut, 7/16"-14.....	4
13	98009049	Flat Washer, 7/16"	8
14	98009012	Lock Washer, 1/2"	2
15	98100095	Hex Head Cap Screw, 1/2"-13 x 1-3/4"	4
16	98100309	Cap Screw, Hex Head, M12-1.75 x 40mm	4

* Not Available As a Service Part

SNO-WAY® INTERNATIONAL, INC.



Hartford, WI 53027 USA
 Website: www.snoway.com
 ©2008 Sno-Way® International