

SNO-WAY[®]

SNOW & ICE CONTROL EQUIPMENT

Assembly & Installation Instructions

**FOR
VEHICLE MOUNT KIT 99100881
USING
VEHICLE CENTER MOUNT 99100890**

**TO FIT
2004 - LATER DODGE DURANGO 4x4
2005 - LATER DODGE DAKOTA 4x4**



1. **THINK SAFETY, ALWAYS WEAR SAFETY GLASSES WHEN PERFORMING THE OPERATIONS PRESCRIBED IN THESE INSTRUCTIONS**
2. **READ ALL INSTRUCTIONS CAREFULLY BEFORE ATTEMPTING INSTALLATION**
3. **BEFORE BEGINNING WORK MAKE SURE TO SET PARKING BRAKE AND CHOCK WHEELS**



MINIMUM VEHICLE RECOMMENDATIONS

Heavy Duty Alternator
Heavy Duty Battery

NOTE: On some vehicles it may be necessary to use a form of load booster to decrease the vehicle's front suspension sag with the snow plow in place. This can be accomplished with the use of supplementary air bags, booster springs, or similar load boosting devices. Since there are different load boosting devices available, it will up to the customer/end user to decide and purchase the product to suit the application, and not the responsibility of Sno-Way International, Inc.

ASSEMBLY TOOLS NEEDED

Drill Bits	1/4", 17/32"
Impact Sockets	7/16" – 1-3/8"
Metric Sockets	10 mm – 19 mm
Wrenches	7/16" – 1-3/8"
Metric Wrenches	10 mm – 19 mm
Torque Wrench	
Rat Tail Pry Bar	
Clamping Devices	

INSTALLATION NOTES

1. **Unless otherwise specified, mount all Vehicle Mount Kit Components to vehicle before tightening any hardware.**
2. **It is recommended that LOCTITE®, or similar thread locking product, be used on ALL mounting hardware (i.e. Nuts, Cap Screws, Bolts, etc.).**
3. Vehicle should be parked on a level surface with a normal vehicle load on the FRONT suspension.
4. Items in parentheses () refer to quantity required for this step. Items in parentheses with a pound sign (#) indicate the part number as found in the parts list on the last page of this document.
Example: (2) 1/2"-13 x 1-1/2" Cap Screws (#8).
5. It may be necessary to relocate license plate holder. Check state and local laws for placement, if needed.

MOUNTING INSTRUCTIONS

1. Remove the bumper by removing the (8) bolts connecting the front bumper to the vehicle frame. Retain the hardware to use in a later step.

NOTE: The existing hardware that secures the bumper to the truck frame will be used to secure the Side Weldments to the vehicle frame, but you cannot put the washer back on that is used in the existing hardware. The washer will not fit on when the Side Weldment is attached so just remove it and use the nut instead. (In some instances you may have to provide the nut needed to secure the bumper and Side Weldments back onto the vehicle frame rail)

2. Position the Side Weldment, LH (#2) to the inside of the vehicle frame rail, aligning the two front holes in the Side Weldment with the lower two bumper bolt holes.
Loosely secure using the existing bumper bolts. (Item #2 is tapered to fit the frame rail.)
Loosely secure the rear portion of the Side Weldment, LH (#2) using a Shim Plate (#5) (on the upper position), a Rear Outer Plate, (4) 1/2" -13 x 1/2" Cap Screws (#8), (6) 1/2" Flat Washers (#10) and (4) 1/2" Nylock Nuts (#9).
Using the front bottom 2 holes in the Side Weldment as a template, drill 17/32" holes through the bottom of the frame rail. Secure using a Nut Plate (#6) (inserted through the front of the frame rail), (2) 1/2"-13 x 1-1/2" Cap Screws (#8) and (2) 1/2" Lock Washers (#11).
3. Position the Side Weldment, RH (#3) to the inside of the vehicle frame rail and repeat step #2 to secure to the frame rail.
4. Install the Vehicle Center Member:
For Dakotas - Install the Vehicle Center Member by securing in between items #2 and #3. Secure each side using (4) 1/2"-13 x 1-1/2" Cap Screws (#8), (1) 1/2" Lock Washer (#11) and (3) 1/2" Nylock Nuts (#9).
For Durangos - Install the Vehicle Center Member by securing in between items #2 and #3. In the gap between the Vehicle Center Member and the Side Weldments, use a total of (4) Spacers (#7) - 2 per side. Secure each side using (4) 1/2"-13 x 2" Cap Screws (#12), (1) 1/2" Lock Washer (#11) and (3) 1/2" Nylock Nuts (#9).

IMPORTANT: Height from the center of the lower Plow mounting holes on the Vehicle Mount Kit to the ground should be between 8" and 10" to insure proper operation.

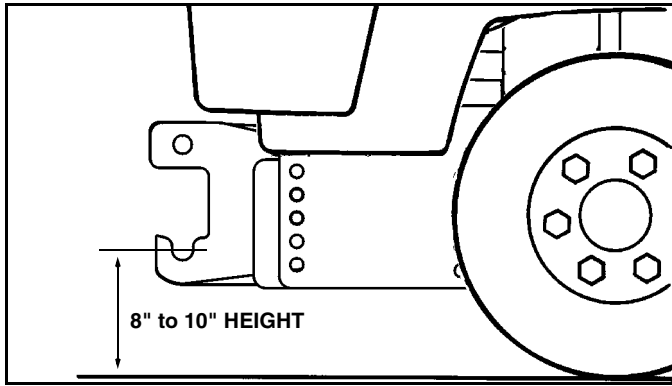

5. Using the torque specification chart provided, torque all cap screws.

TORQUE SPECIFICATIONS FOR STANDARD MACHINE HARDWARE					
Bolt Size	GR.2 Dry	GR.5 Dry	GR.8 Dry	Metric Size	GR.8.8 Dry
1/4"	66*	9	12	M8	17
5/16"	11	17	25	M10	35
3/8"	20	30	45	M12	60
7/16"	32	50	70	M14	95
1/2"	50	75	110	M16	155
9/16"	70	110	150		
5/8"	100	150	220		
3/4"	175	260	380		
7/8"	170	430	600		
1"	250	640	900		

Note: These torque values are to be used for all hardware. Unless otherwise specified, all torque values must meet this specification.
 Note: All torque values are in Ft.-Lbs unless otherwise stated
 Note: *In-Lbs

REMEMBER After 5 to 10 hours of snowplow usage, re-torque all Cap Screws!

6. Reinstall bumper using original hardware.

PARTS LIST

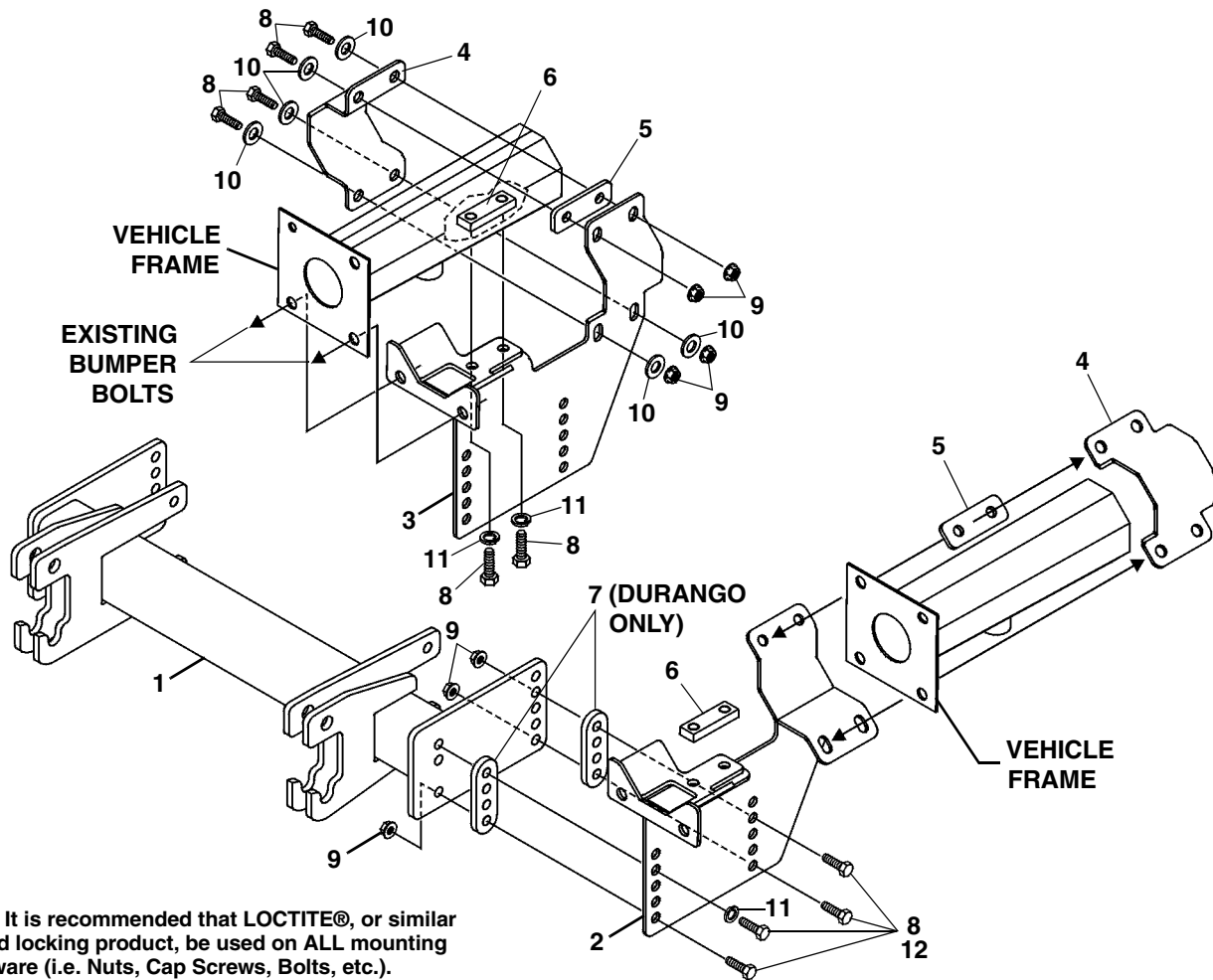

ITEM	PART NO.	DESCRIPTION	QTY.
1	99100890	Vehicle Center Member (96108560)	1
2	96108639*	Side Weldment, LH	1
3	96109051*	Side Weldment, RH.....	1
4	96108640*	Rear Outer Plate	2
5	96108641*	Shim Plate.....	2
6	96100940*	Nut Plate	2
7	96108688*	Spacer.....	4
8	98009010	Cap Screw, Hex Head, 1/2"-13 x 1-1/2"	20
9	98009013	Nut, Nylock, 1/2"	14
10	98009011	Washer, Flat, 1/2".....	14
11	98009012	Washer, Lock, 1/2"	6
12	98100094	Cap Screw, Hex Head, 1/2"-13 x 2"	8

* Not Available As a Service Part

SNO-WAY® INTERNATIONAL, INC.



Hartford, WI 53027 USA
 Website: www.snoway.com
 ©2007 Sno-Way® International

www.storksplows.com