

SNO-WAY®

SNOW & ICE CONTROL EQUIPMENT

ASSEMBLY & INSTALLATION INSTRUCTIONS

**VEHICLE MOUNT KIT 99101087
AND
VEHICLE CENTER MEMBER 99100890**

TO FIT
2009 & Later FORD F150 4x4 (without EcoBoost V6)
2011 & Later FORD F150 4x4 (with EcoBoost V6)

Sno-Way®; Down Pressure® and EIS® are registered trademarks of Sno-Way International, Inc.
ProControl™, MegaBlade™, V-Wing™, E-Z Switch™, Revolution™, MaxAdjust™, SpeedLock™, and
QuickJack™ are trademarks of Sno-Way International, Inc.

©2019 Sno-Way® International

97101721E



1. **THINK SAFETY, ALWAYS WEAR SAFETY GLASSES WHEN PERFORMING THE OPERATIONS PRESCRIBED IN THESE INSTRUCTIONS**
2. **READ ALL INSTRUCTIONS CAREFULLY BEFORE ATTEMPTING INSTALLATION**
3. **BEFORE BEGINNING WORK MAKE SURE TO SET PARKING BRAKE AND CHOCK WHEELS**



MINIMUM VEHICLE RECOMMENDATIONS

Heavy Duty Alternator
 Heavy Duty Battery
 Manufacturers Snow Plow Package

NOTE: On some vehicles it may be necessary to use a form of load booster to decrease the vehicle's front suspension sag with the snow plow in place. This can be accomplished with the use of supplementary air bags, booster springs, or similar load boosting devices. Since there are different load boosting devices available, it will up to the customer/end user to decide and purchase the product to suit the application, and not the responsibility of Sno-Way International,

ASSEMBLY TOOLS NEEDED

Drill Bits	1/4" - 17/32"
Impact Sockets	7/16" – 1-3/8"
Wrenches	7/16" – 1-3/8"
Torque Wrench	
Rat Tail Pry Bar	
Center Punch and Hammer	
C-Clamp	
Hacksaw	
Screwdrivers	

INSTALLATION NOTES

1. **Unless otherwise specified, mount all Vehicle Mount Kit components to vehicle before tightening any hardware.**
2. **It is recommended that LOCTITE®, or similar thread locking product, be used on ALL mounting hardware (i.e. Nuts, Cap Screws, Bolts, etc.).**
3. Vehicle should be parked on a level surface with a normal vehicle load on the FRONT suspension.
4. Items in parentheses () refer to quantity required for this step. Items in parentheses with a pound sign (#) indicate the part number as found in the parts list on the last page of this document.
 Example: (10) Washer, Lock, 1/2" (#8).
5. It maybe necessary to relocate license plate holder. Check state and local laws for placement, if needed.
6. If the subframe is being installed on a 2009 - 2014 F-150 **without** a EcoBoost V6 engine, proceed to the next section.

If the subframe is being installed on a 2011 - 2014 F-150 **with** a EcoBoost V6 engine, "Shim Plate Kit 96114192 is required. Proceed to "MOUNTING INSTRUCTIONS (2011-2014 models with EcoBoost V6 Engine)" on page 3.

If the subframe is being installed on a 2015 & Later F-150 **without** a EcoBoost V6 engine, proceed to "MOUNTING INSTRUCTIONS (2015 & Later models without a EcoBoost V6 engine)" on page 5.

If the subframe is being installed on a 2015 & later F-150 **with** a EcoBoost V6 engine, "Intercooler Support Bracket 96115859 is required. Proceed to "MOUNTING INSTRUCTIONS (2015 & Later models with a EcoBoost V6 engine)" on page 7.

MOUNTING INSTRUCTIONS

(2009 - 2014 models without EcoBoost V6 Engine)

1. Detach the rubber splash shield (if equipped) at the bottom edge of the bumper by removing the plastic fasteners. From the top of the bumper, remove the cap screws. Next remove the two hooks from the vehicle frame and retain the hardware for the Vehicle Mount Kit installation. Store the tow hooks separately for reuse if the Vehicle Mount Kit is removed.
2. If equipped, remove the skid plate and save with hardware for re-installation if the Vehicle Mount Kit is removed. Also, if equipped with fog lights, disconnect the vehicle harness from the back of the fog lights.
3. Remove the four nuts (two per side) from the back of the bumper brackets. Remove the bumper now that all of the hardware is disconnected.
4. Install (1) Side Weldment, LH (#2): Align the tow hook bolts in the vehicle frame with the two front slots in the horizontal lip of the Side Weldment. Use the existing tow hook hardware to secure the Side Weldment loosely to the bottom of the vehicle frame. Verify that the Side Weldment is tight against the vehicle frame by using a C-clamp to hold the front of the Side Weldment to the frame. The three slots on the horizontal lip of the Side Weldment align with the holes in the bottom of the vehicle frame rail. The hole in the center vertical tab in the Side Weldment aligns with a hole in the side of the vehicle frame rail. Using the Side Weldment as a template mark the location of the holes in the front and rear most vertical tabs with a center punch. Remove the side weldment, drill a pilot hole and then a 17/32" dia. hole through the outer wall of the frame.

5. Secure the Side Weldment, LH (#2) as follows:

- In the rear-most tab, install (1) Handle Bolt Weldment, 1/2"-13 x 1 1/2" (#4) with (1) 1/2" Plain Washer (#10) inserted into the frame rail and secure using (1) 1/2" Locknut (#6).
- In the middle tab, install (1) Handle Bolt Weldment, 1/2"-13 x 1 1/4" (#5) with (1) Backing Plate (#7) inserted into the frame rail and secure using (1) 1/2" Locknut (#6).
- In the front-most tab, install (1) Handle Bolt Weldment, 1/2"-13 x 1 1/4" (#5) with (1) 1/2" Plain Washer (#10) inserted into the frame rail and secure using (1) 1/2" Locknut (#6).
- In the third slot from the front in the horizontal lip, install (1) Handle Bolt Weldment, 1/2"-13 x 1 1/2" (#4) with (1) 1/2" Plain Washer (#10) inserted into the frame rail and secure using (1) 1/2" Plain Washer (#10) and (1) 1/2" Locknut (#6).

6. Repeat Step #4 and 5 to install (1) Side Weldment, RH (#3).

7. Attach the Vehicle Center Member (#1) to the Side Weldments, LH (#2) and RH (#3). Insert (4) Spacers (#8), 2 per side, as shown on the Part List. Secure using (8) 1/2"-13 x 2" Cap Screws (#9), (2) 1/2" Lock Washers (#11) in the threaded holes and (6) 1/2" Locknuts (#6).

8. With all the components now in place, tighten all hardware. Using the Torque Specification Chart provided, torque all Cap Screws.

9. Reinstall the bumper. Reconnect the fog lamp harness connectors if so equipped.

IMPORTANT: The bumper will have to be cut (notched) to achieve the desired Vehicle Mount Kit height requirement.

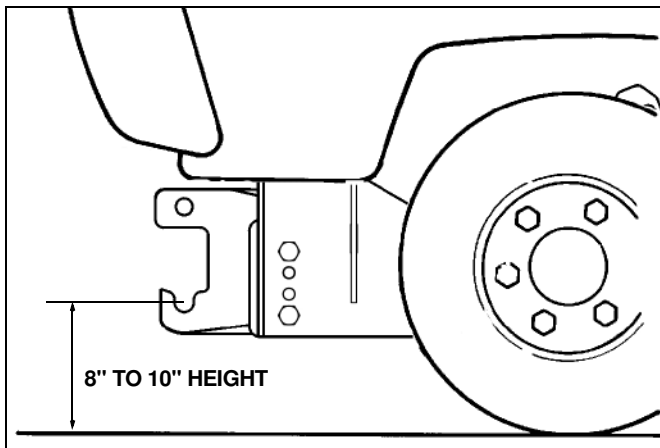

Figure 1

IMPORTANT: Height from the center of the lower plow mounting holes on the Vehicle Mount Kit to the ground should be between 8" and 10" to insure proper operation.

TORQUE SPECIFICATIONS FOR STANDARD MACHINE HARDWARE

Bolt Size	GR.2 Dry	GR.5 Dry	GR.8 Dry	Metric Size	GR.8.8 Dry
1/4"	66*	9	12	M8	17
5/16"	11	17	25	M10	35
3/8"	20	30	45	M12	60
7/16"	32	50	70	M14	95
1/2"	50	75	110	M16	155
9/16"	70	110	150		
5/8"	100	150	220		
3/4"	175	260	380		
7/8"	170	430	600		
1"	250	640	900		

Note: These torque values are to be used for all hardware. Unless otherwise specified, all torque values must meet this specification.
 Note: All torque values are in Ft.-Lbs unless otherwise stated
 Note: *In-Lbs

REMEMBER After 5 to 10 hours of snowplow usage, re-torque all Cap Screws!

MOUNTING INSTRUCTIONS (2011-2014 models with EcoBoost V6 Engine)

1. Detach the rubber splash shield (if equipped) at the bottom edge of the bumper by removing the plastic fasteners. From the top of the bumper, remove the cap screws. Next remove the two hooks from the vehicle frame and retain the hardware for the Vehicle Mount Kit installation. Store the tow hooks separately for reuse if the Vehicle Mount Kit is removed.
2. If equipped, remove the skid plate and save with hardware for re-installation if the Vehicle Mount Kit is removed. Also, if equipped with fog lights, disconnect the vehicle harness from the back of the fog lights.
3. Temporarily remove the top intercooler bracket by removing two fasteners (one per side). Doing this will make step 4 much easier. (See Figure 2)

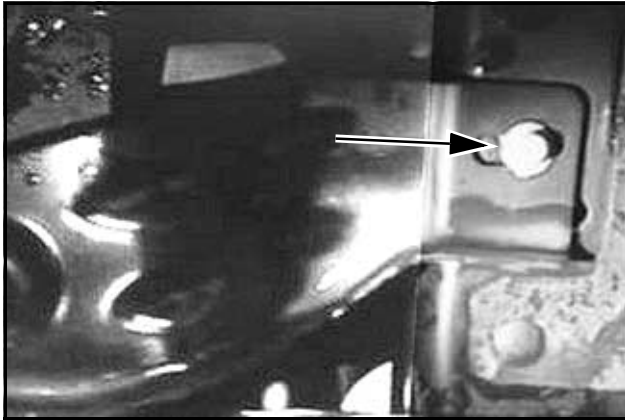

Figure 2

4. Remove the four nuts (two per side) from the back of the bumper brackets. Remove the bumper now that all of the hardware is disconnected.
5. Temporarily remove the bottom intercooler bracket, by removing two fasteners (one per side). Its recommended to have the intercooler securely held in place while the bottom bracket is removed. Then remove all the hardware used in the two holes seen below. (See Figure 3)

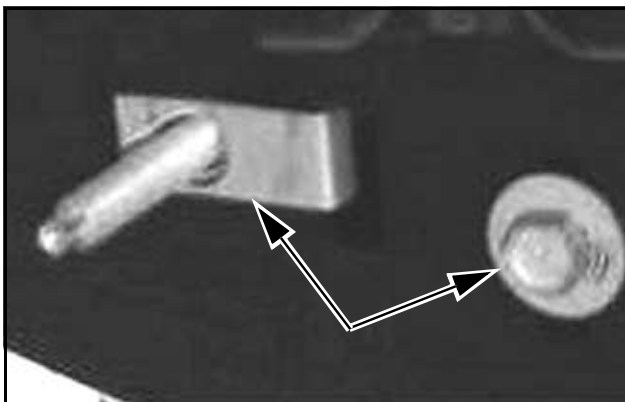

Figure 3

6. Grind the flange at the rear of the bracket away so the side weldments can sit flat against the bracket. Do this on both sides. (See Figure 4)

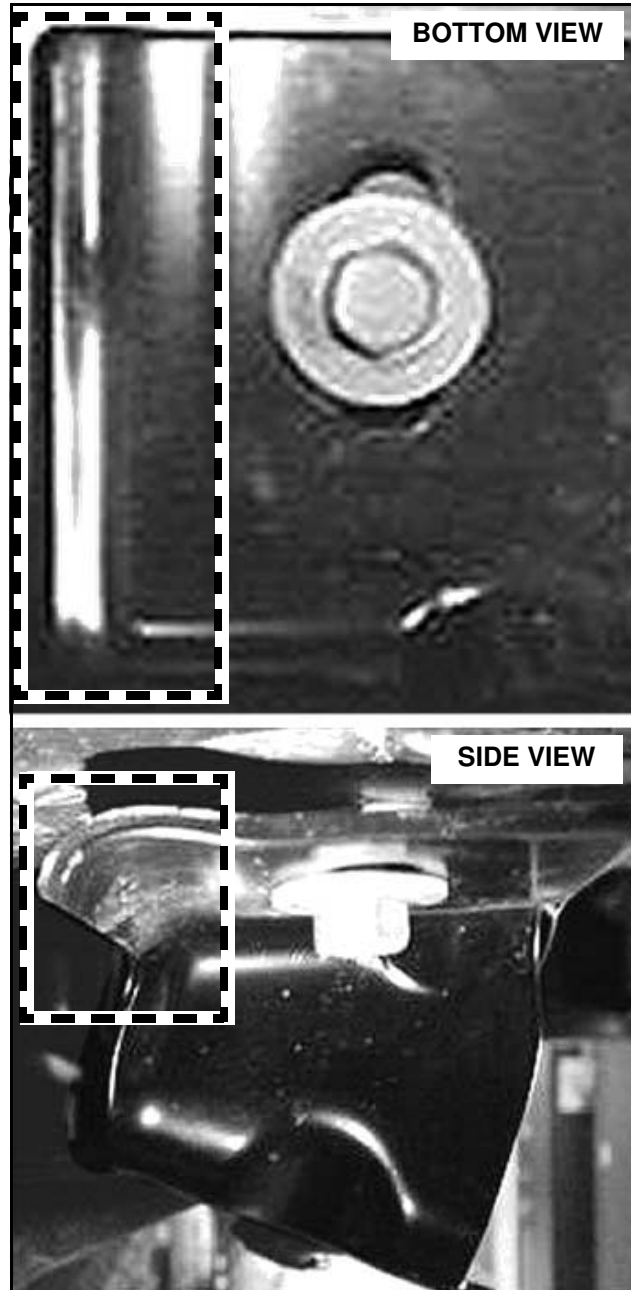

Figure 4

7. Hold the bottom intercooler bracket back to where it was before.

8. Install (1) Side Weldment, LH (#2) and (1) Shim Plate (#12): Align Shim Plate (#12) over the three slots on the horizontal lip of the Side Weldment. Align the tow hook bolts in the vehicle frame with the two front slots in the horizontal lip of the Side Weldment and Shim Plate. Use the existing tow hook hardware to secure the Side Weldment loosely to the bottom of the vehicle frame. Verify that the Side Weldment and Shim Plate is tight against the vehicle frame and bottom intercooler bracket by using a C-clamp to hold the front of the Side Weldment to the frame. The four slots on the horizontal lip of the Side Weldment align with the holes in the bottom of the vehicle frame rail and bottom intercooler bracket. The hole in the center vertical tab in the Side Weldment aligns with a hole in the side of the vehicle frame rail. Using the Side Weldment as a template mark the location of the holes in the front and rear most vertical tabs with a center punch. Remove the side weldment, drill a pilot hole and then a 17/32" dia. hole through the outer wall of the frame.
9. Secure the Side Weldment, LH (#2) as follows:
 - a. In the rear-most tab, install (1) Handle Bolt Weldment, 1/2"-13 x 1-1/2" (#4) with (1) 1/2" Plain Washer (#10) inserted into the frame rail and secure using (1) 1/2" Locknut (#6).
 - b. In the middle tab, install (1) Handle Bolt Weldment, 1/2"-13 x 1-1/4" (#5) with (1) Backing Plate (#7) inserted into the frame rail and secure using (1) 1/2" Locknut (#6).
 - c. In the front-most tab, install (1) Handle Bolt Weldment, 1/2"-13 x 1-1/4" (#5) with (1) 1/2" Plain Washer (#10) inserted into the frame rail and secure using (1) 1/2" Locknut (#6).
 - d. In the third slot from the front in the horizontal lip, install (1) Handle Bolt Weldment, 1/2"-13 x 1-1/2" (#4) with (1) 1/2" Plain Washer (#10) inserted into the frame rail and bottom intercooler bracket, and then secure using (1) 1/2" Plain Washer (#10) and (1) 1/2" Locknut (#6).
10. Repeat Steps 8 & 9 to install (1) Side Weldment, RH (#3).
11. Attach the Vehicle Center Member (#1) to the Side Weldments, LH (#2) and RH (#3). Insert (4) Spacers (#8), 2 per side, as shown on the Part List. Secure using (8) 1/2"-13 x 2" Cap Screws (#9), (2) 1/2" Lock Washers (#11) in the threaded holes and (6) 1/2" Locknuts (#6).
12. With all the components now in place, tighten all hardware. Using the Torque Specification Chart provided, torque all Cap Screws.
13. Reinstall the bumper and the top intercooler bracket that was removed in step 3. Reconnect the fog lamp harness connectors if so equipped.

IMPORTANT: The bumper will have to be cut (notched) to achieve the desired Vehicle Mount Kit height requirement.

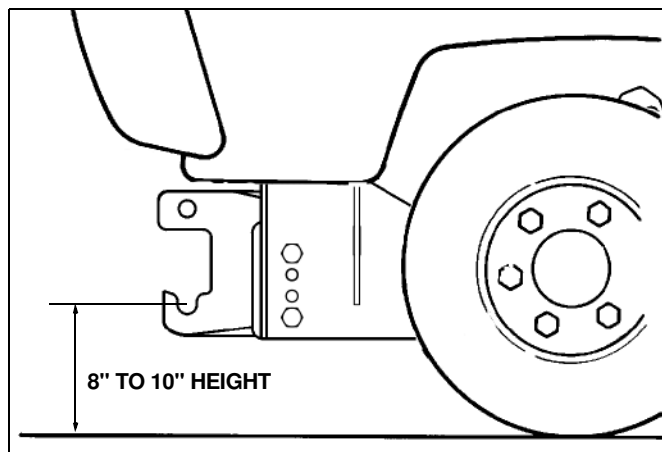

Figure 5

IMPORTANT: Height from the center of the lower plow mounting holes on the Vehicle Mount Kit to the ground should be between 8" and 10" to insure proper operation.

TORQUE SPECIFICATIONS FOR STANDARD MACHINE HARDWARE					
Bolt Size	GR.2 Dry	GR.5 Dry	GR.8 Dry	Metric Size	GR.8.8 Dry
1/4"	66*	9	12	M8	17
5/16"	11	17	25	M10	35
3/8"	20	30	45	M12	60
7/16"	32	50	70	M14	95
1/2"	50	75	110	M16	155
9/16"	70	110	150		
5/8"	100	150	220		
3/4"	175	260	380		
7/8"	170	430	600		
1"	250	640	900		

Note: These torque values are to be used for all hardware. Unless otherwise specified, all torque values must meet this specification.
Note: All torque values are in Ft.-Lbs unless otherwise stated
Note: *In-Lbs

REMEMBER After 5 to 10 hours of snowplow usage, re-torque all Cap Screws!

MOUNTING INSTRUCTIONS (2015 & Later models without EcoBoost Engine)

1. Open the Hood. Remove all the plastic fasteners holding the rubber cover spanning between the radiator and grill. Remove the rubber cover. (See Figure 6)

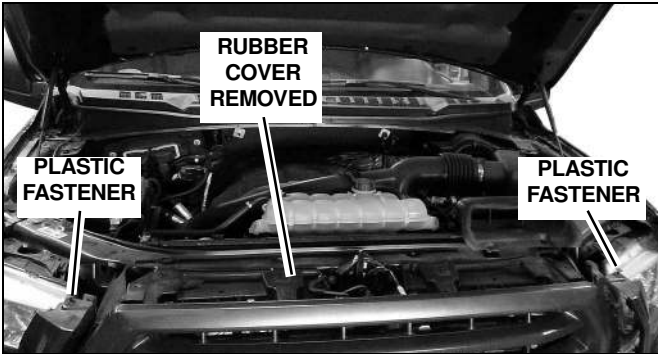

Figure 6

2. Remove the plastic fasteners next to the grill, holding the headlight trim in place. (See Figure 6)
3. Pull the trim away from the headlights and grill just enough to access the remaining 2 screws holding in the grill. Remove 1 screw on each side of the grill. Also disconnect any harnesses running to the grill and any other rubber trim between the headlights and grill. (See Figure 7)

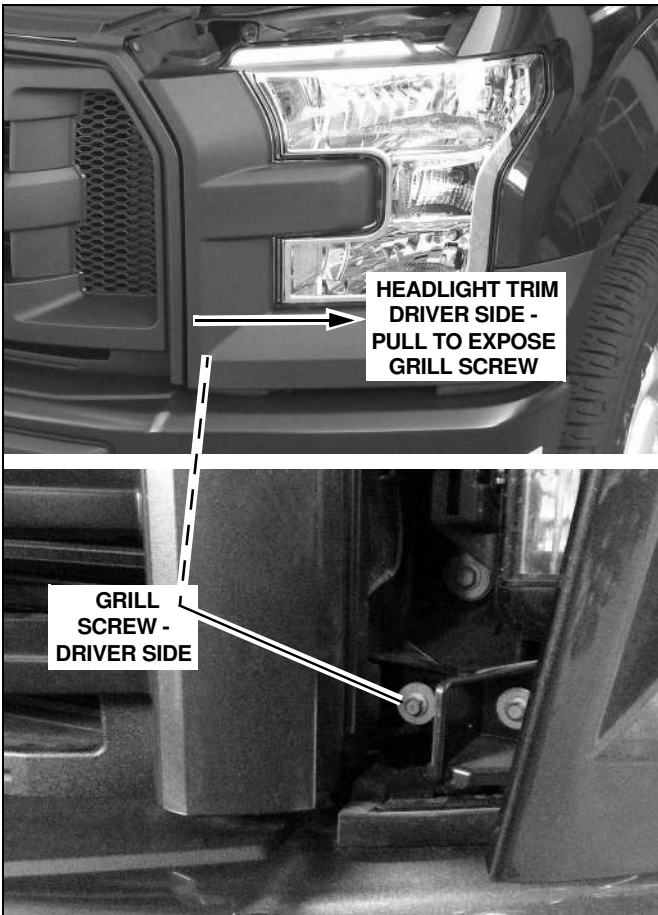

Figure 7

4. Remove the grill by lifting straight up and then out. (See Figure 8)

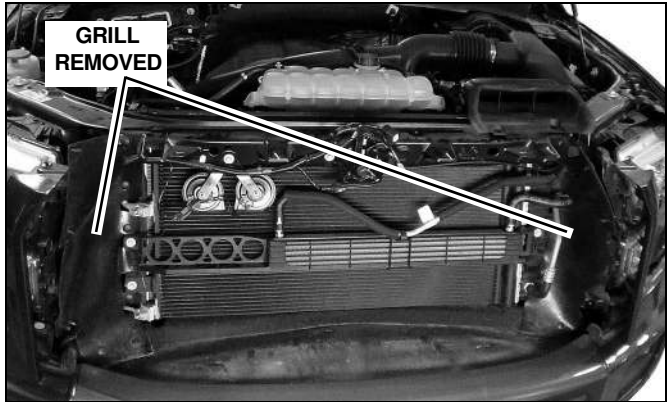

Figure 8

5. Remove the plastic fasteners holding the plastic divider to the bumper and pull the front bumper cover straight out of the bumper. (See Figure 9)

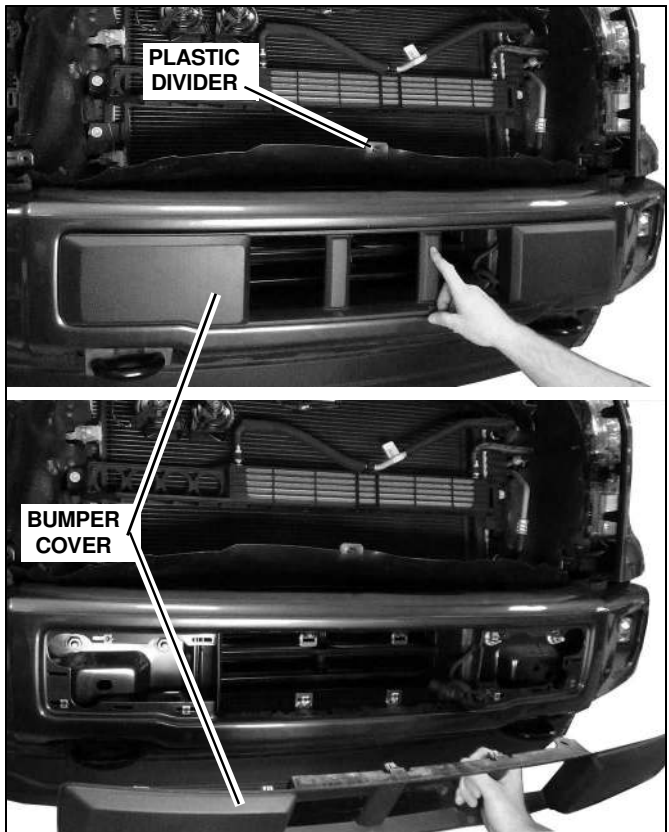

Figure 9

- Disconnect the fog lamps, if equipped and any harnesses attached to the bumper. Remove the 3 nuts on each side, holding the bumper to the truck frame. Remove the bumper. (See Figure 10)

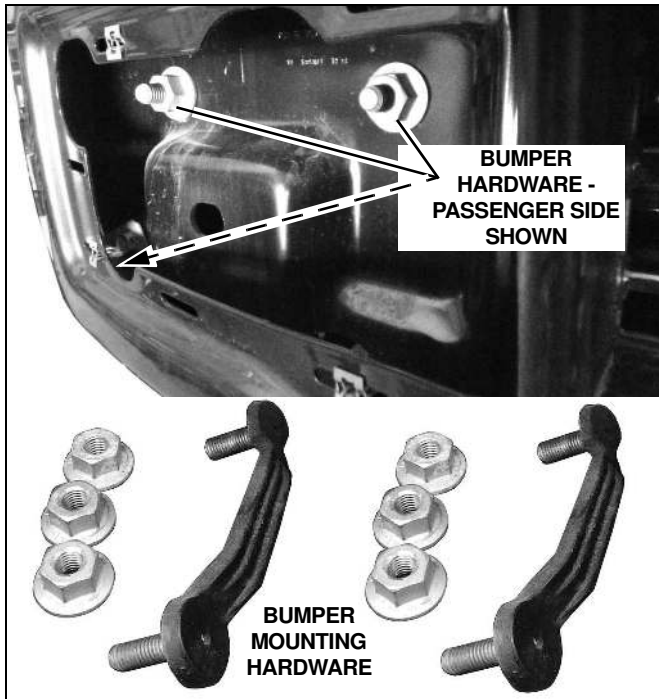

Figure 10

- Unscrew and remove the bottom plastic valance from the bumper. Keep the bottom valance for reinstallation if the Mount Kit is removed. Then cut and remove the narrow lip of the plastic portion of the bumper directly below where the tow hooks protruded from. (See Figure 11)

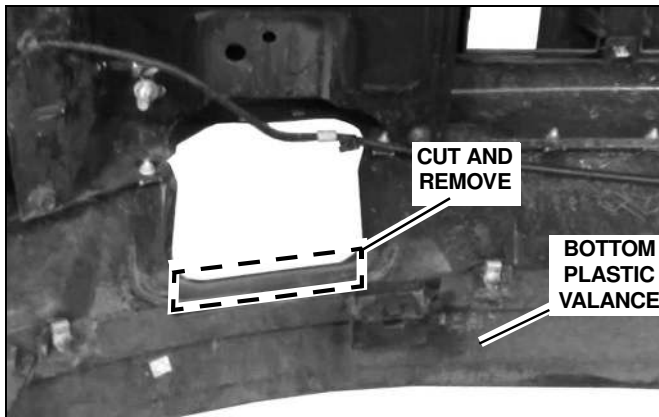

Figure 11

- Remove the tow hooks. Retain the hardware for the Vehicle Mount Kit installation. Store the tow hooks for reuse if the Vehicle Mount Kit is removed.
- Install (1) Side Weldment, LH (#2): Align the tow hook bolts in the vehicle frame with the two front slots in the horizontal lip of the Side Weldment. Use the existing tow hook hardware to secure the Side Weldment loosely to the bottom of the vehicle frame. Verify that the Side Weldment is tight against the vehicle frame by using a C-clamp to hold the front of

the Side Weldment to the frame. Using the Side Weldment as a template mark the location of the remaining holes with a center punch. There are three on the vertical tabs and a slot on the horizontal lip directly behind the tow hook holes. Remove the side weldment, drill a pilot hole and then a 17/32" dia. hole through the outer wall of the frame.

- Secure the Side Weldment, LH (#2) as follows:
 - In the rear-most tab, install (1) Handle Bolt Weldment, 1/2"-13 x 1-1/2" (#4) with (1) 1/2" Plain Washer (#10) inserted into the frame rail and secure using (1) 1/2" Locknut (#6).
 - In the middle tab, install (1) Handle Bolt Weldment, 1/2"-13 x 1-1/4" (#5) with (1) Backing Plate (#7) inserted into the frame rail and secure using (1) 1/2" Locknut (#6).
 - In the front-most tab, install (1) Handle Bolt Weldment, 1/2"-13 x 1-1/4" (#5) with (1) 1/2" Plain Washer (#10) inserted into the frame rail and secure using (1) 1/2" Locknut (#6).
 - In the third slot from the front in the horizontal lip, install (1) Handle Bolt Weldment, 1/2"-13 x 1-1/2" (#4) with (1) 1/2" Plain Washer (#10) inserted into the frame rail and secure using (1) 1/2" Plain Washer (#10) and (1) 1/2" Locknut (#6).
- Repeat Step #9 and 10 to install (1) Side Weldment, RH (#3).
- Attach the Vehicle Center Member (#1) to the Side Weldments, LH (#2) and RH (#3). Insert (4) Spacers (#8), 2 per side, as shown on the Part List. Secure using (8) 1/2"-13 x 2" Cap Screws (#9), (2) 1/2" Lock Washers (#11) in the threaded holes and (6) 1/2" Locknuts (#6).
- With all the components now in place, tighten all hardware. Using the Torque Specification Chart provided, torque all Cap Screws.
- Reinstall the bumper and grill by following steps 1 through 6 in reverse order.

IMPORTANT: The bumper will have to be cut (notched) to achieve the desired Vehicle Mount Kit height requirement.

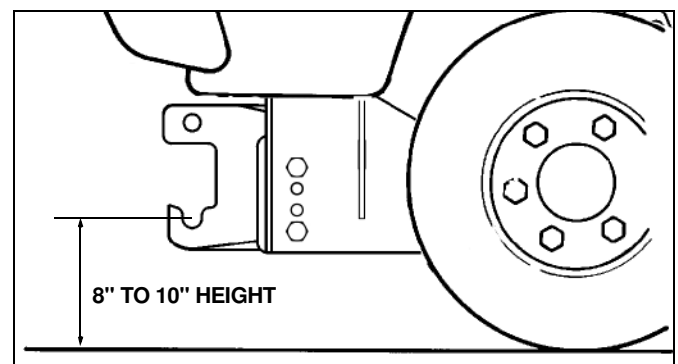

Figure 12

IMPORTANT: Height from the center of the lower plow mounting holes on the Vehicle Mount Kit to the ground should be between 8" and 10" to insure proper operation.

MOUNTING INSTRUCTIONS

(2015 & Later models with EcoBoost V6 Engine)

1. Open the Hood. Remove the rubber cover spanning between the radiator and grill by removing the plastic fasteners holding it in place. (See Figure 13)

TORQUE SPECIFICATIONS FOR STANDARD MACHINE HARDWARE					
Bolt Size	GR.2 Dry	GR.5 Dry	GR.8 Dry	Metric Size	GR.8.8 Dry
1/4"	66*	9	12	M8	17
5/16"	11	17	25	M10	35
3/8"	20	30	45	M12	60
7/16"	32	50	70	M14	95
1/2"	50	75	110	M16	155
9/16"	70	110	150		
5/8"	100	150	220		
3/4"	175	260	380		
7/8"	170	430	600		
1"	250	640	900		

Note: These torque values are to be used for all hardware. Unless otherwise specified, all torque values must meet this specification.
 Note: All torque values are in Ft.-Lbs unless otherwise stated
 Note: *In-Lbs

REMEMBER After 5 to 10 hours of snowplow usage, re-torque all Cap Screws!



Figure 13

2. Remove the plastic fasteners next to the grill, holding the headlight trim in place. (See Figure 13)
3. Pull the trim away from the headlights and grill just enough to access the remaining 2 screws holding in the grill. Remove 1 screw on each side of the grill. Also disconnect any harnesses running to the grill and any other rubber trim between the headlights and grill. (See Figure 14)

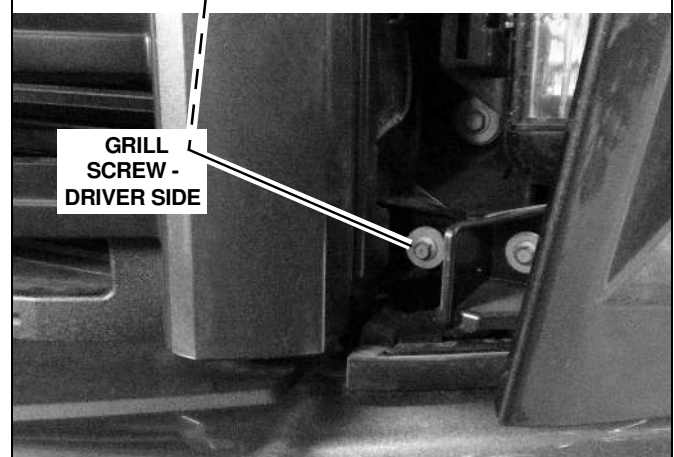

Figure 14

4. Remove the grill by lifting straight up and then out.
(See Figure 15)

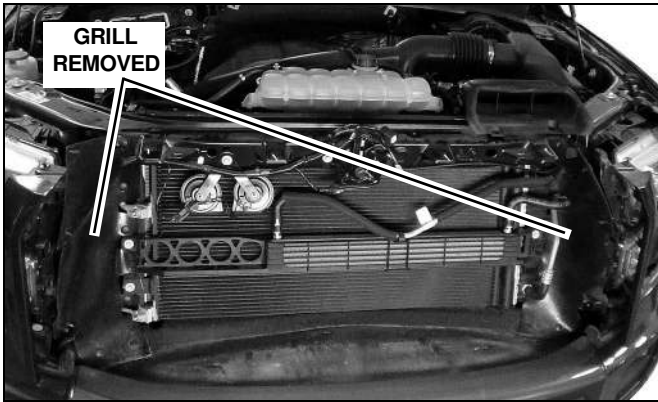

Figure 15

5. Remove the plastic fasteners holding the plastic divider to the bumper and pull the front bumper cover straight out of the bumper. (See Figure 16)

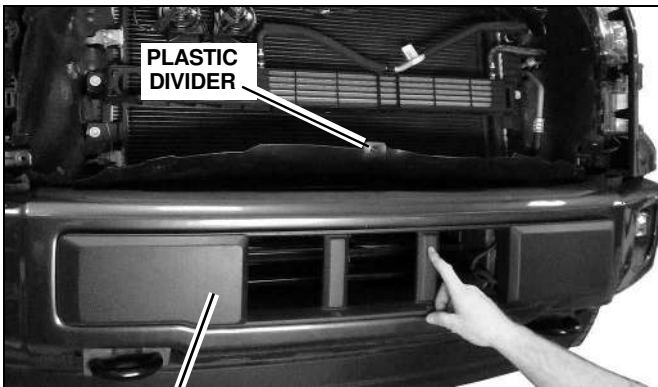

Figure 16

6. Disconnect the fog lamps, if equipped and any harnesses attached to the bumper. Remove the 3 nuts on each side, holding the bumper to the truck frame. Remove the bumper. (See Figure 17)

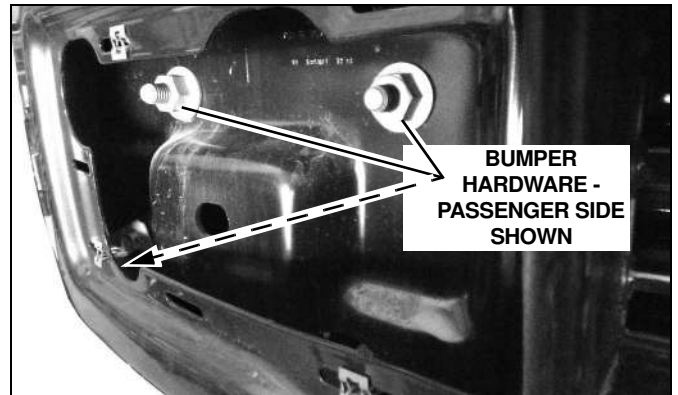

Figure 17

7. Disconnect all harness connections and dismantle any harness mounting fasteners that will prohibit the intercooler air dam from being removed. (See Figure 18)

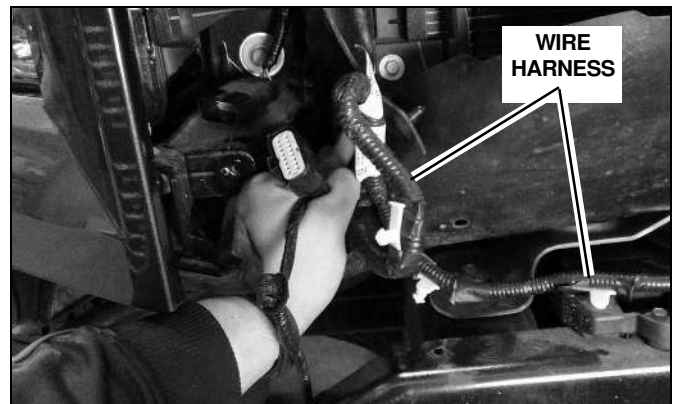

Figure 18

8. Remove the 2 screws from each side of the intercooler air dam holding it to the truck frame. Then remove the intercooler air dam and harnesses attached from the truck. (See Figure 19)

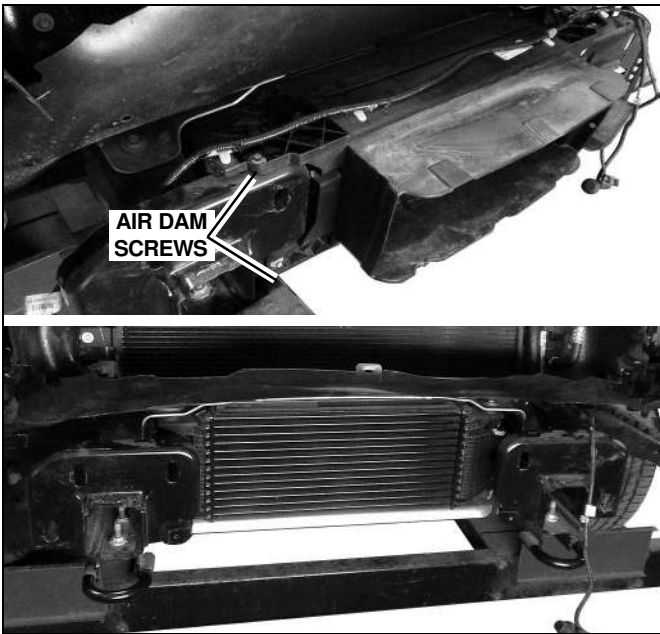

Figure 19

9. Loosen the 2 hose clamps from the passenger side of the intercooler and disconnect. (See Figure 20)

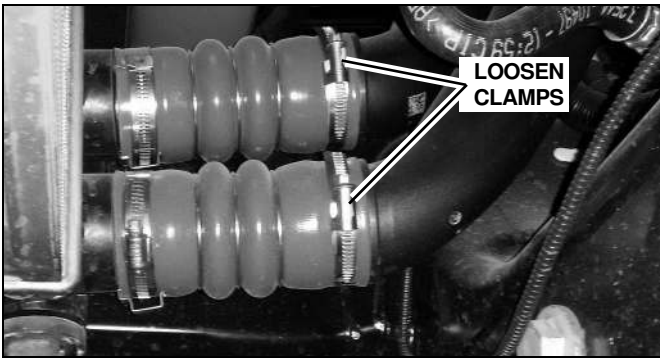

Figure 20

10. Disconnect the 2 hoses on the driver side of the intercooler and the 2 pin connector. (See Figure 21)

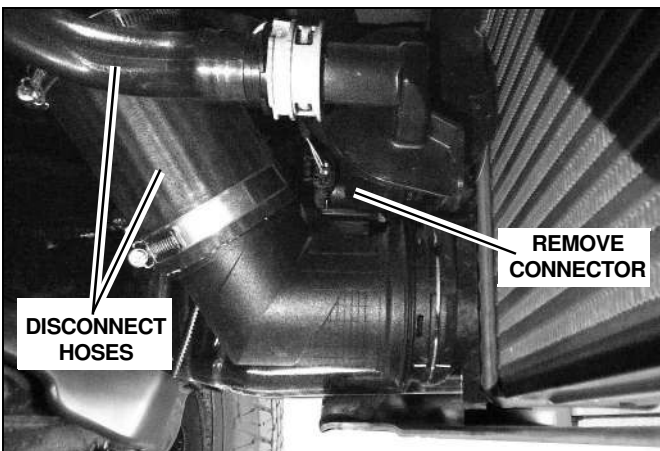

Figure 21

11. Remove the 2 screws for the lower intercooler bracket, then remove the intercooler bracket and intercooler from the truck. Cover the open ends of hose to prevent any contaminants from entering during remainder of subframe install. (See Figure 22)

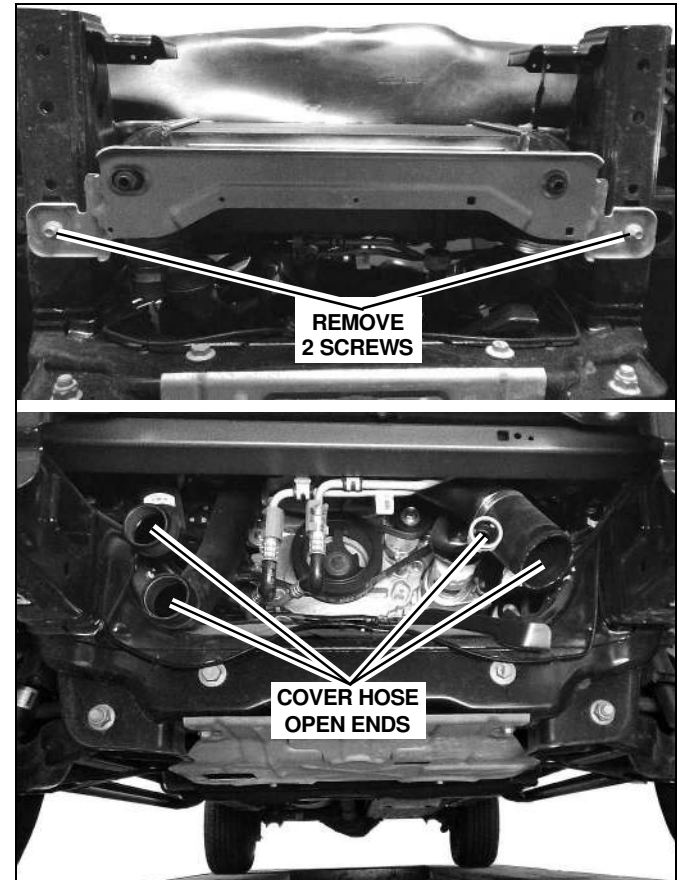

Figure 22

12. Unscrew and remove the bottom plastic valance from the bumper. Keep the bottom valance for reinstallation if the Mount Kit is removed. Then cut and remove the narrow lip of the plastic portion of the bumper directly below where the tow hooks protruded from. (See Figure 23)

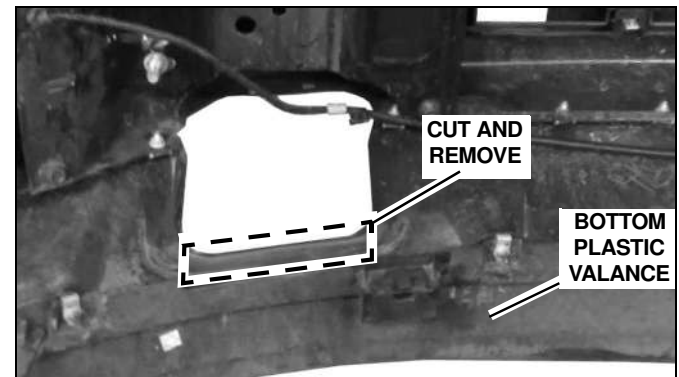

Figure 23

13. Remove the tow hooks. Retain the hardware for the Vehicle Mount Kit installation. Store the tow hooks for reuse if the Vehicle Mount Kit is removed.

14. Install (1) Side Weldment, LH (#2): Align the tow hook bolts in the vehicle frame with the two front slots in the horizontal lip of the Side Weldment. Use the existing tow hook hardware to secure the Side Weldment loosely to the bottom of the vehicle frame. Verify that the Side Weldment is tight against the vehicle frame by using a C-clamp to hold the front of the Side Weldment to the frame. Using the Side Weldment as a template mark the location of the remaining holes with a center punch. There are three on the vertical tabs and a slot on the horizontal lip directly behind the tow hook holes. Remove the side weldment, drill a pilot hole and then a 17/32" dia. hole through the outer wall of the frame.
15. Secure the Side Weldment, LH (#2) as follows:
 - a. In the rear-most tab, install (1) Handle Bolt Weldment, 1/2"-13 x 1-1/2" (#4) with (1) 1/2" Plain Washer (#10) inserted into the frame rail and secure using (1) 1/2" Locknut (#6).
 - b. In the middle tab, install (1) Handle Bolt Weldment, 1/2"-13 x 1-1/4" (#5) with (1) Backing Plate (#7) inserted into the frame rail and secure using (1) 1/2" Locknut (#6).
 - c. In the front-most tab, install (1) Handle Bolt Weldment, 1/2"-13 x 1-1/4" (#5) with (1) 1/2" Plain Washer (#10) inserted into the frame rail and secure using (1) 1/2" Locknut (#6).
 - d. In the third slot from the front in the horizontal lip, install (1) Handle Bolt Weldment, 1/2"-13 x 1-1/2" (#4) with (1) 1/2" Plain Washer (#10) inserted into the frame rail and secure using (1) 1/2" Plain Washer (#10) and (1) 1/2" Locknut (#6).
16. Repeat Step #14 and 15 to install (1) Side Weldment, RH (#3).
17. Attach the Vehicle Center Member (#1) to the Side Weldments, LH (#2) and RH (#3). Insert (4) Spacers (#8), 2 per side, as shown on the Part List. Secure using (8) 1/2"-13 x 2" Cap Screws (#9), (2) 1/2" Lock Washers (#11) in the threaded holes and (6) 1/2" Locknuts (#6).
18. Hold the intercooler in its installed position and re-connect all items that were disconnected in Steps #9 and 10.
19. Install Intercooler Support Bracket (#14). Position the two large slots in item #14 over the mounting studs of the intercooler and align the four holes in item #14 with the four rear holes of items #2 and 3. Take out and re-install the hardware that was installed in those rear holes from Step #17 so the bolts also insert through item #14.
20. With all the components now in place, tighten all hardware. Using the Torque Specification Chart provided, torque all Cap Screws.

21. Depending on the height of which item #1 is installed, the top mounting tab of the inside plates may need to be cut off to avoid interference with the Intercooler Air Dam. Place the Intercooler Air Dam into its install position. If there is an interference, cut away what is interfering and paint the cut area to prevent corrosion. If there is no interference or the interference has been fixed, then bolt the Intercooler Air Dam in place with the hardware removed in Step #8.
22. Reinstall the bumper and grill by following steps 1 through 7 in reverse order.

IMPORTANT: The bumper will have to be cut (notched) to achieve the desired Vehicle Mount Kit height requirement.

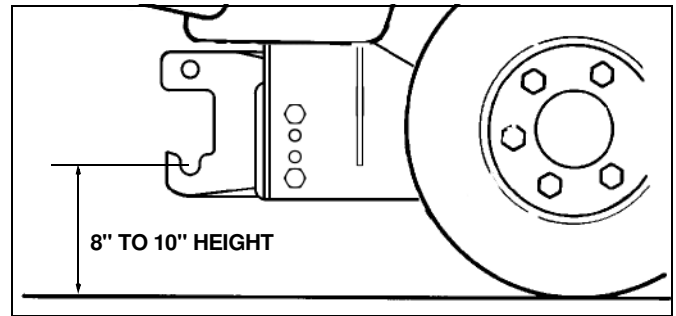

Figure 24

IMPORTANT: Height from the center of the lower plow mounting holes on the Vehicle Mount Kit to the ground should be between 8" and 10" to insure proper operation.

TORQUE SPECIFICATIONS FOR STANDARD MACHINE HARDWARE					
Bolt Size	GR.2 Dry	GR.5 Dry	GR.8 Dry	Metric Size	GR.8.8 Dry
1/4"	66*	9	12	M8	17
5/16"	11	17	25	M10	35
3/8"	20	30	45	M12	60
7/16"	32	50	70	M14	95
1/2"	50	75	110	M16	155
9/16"	70	110	150		
5/8"	100	150	220		
3/4"	175	260	380		
7/8"	170	430	600		
1"	250	640	900		

Note: These torque values are to be used for all hardware. Unless otherwise specified, all torque values must meet this specification.
 Note: All torque values are in Ft.-Lbs unless otherwise stated
 Note: *In-Lbs

REMEMBER After 5 to 10 hours of snowplow usage, re-torque all Cap Screws!

PARTS LIST

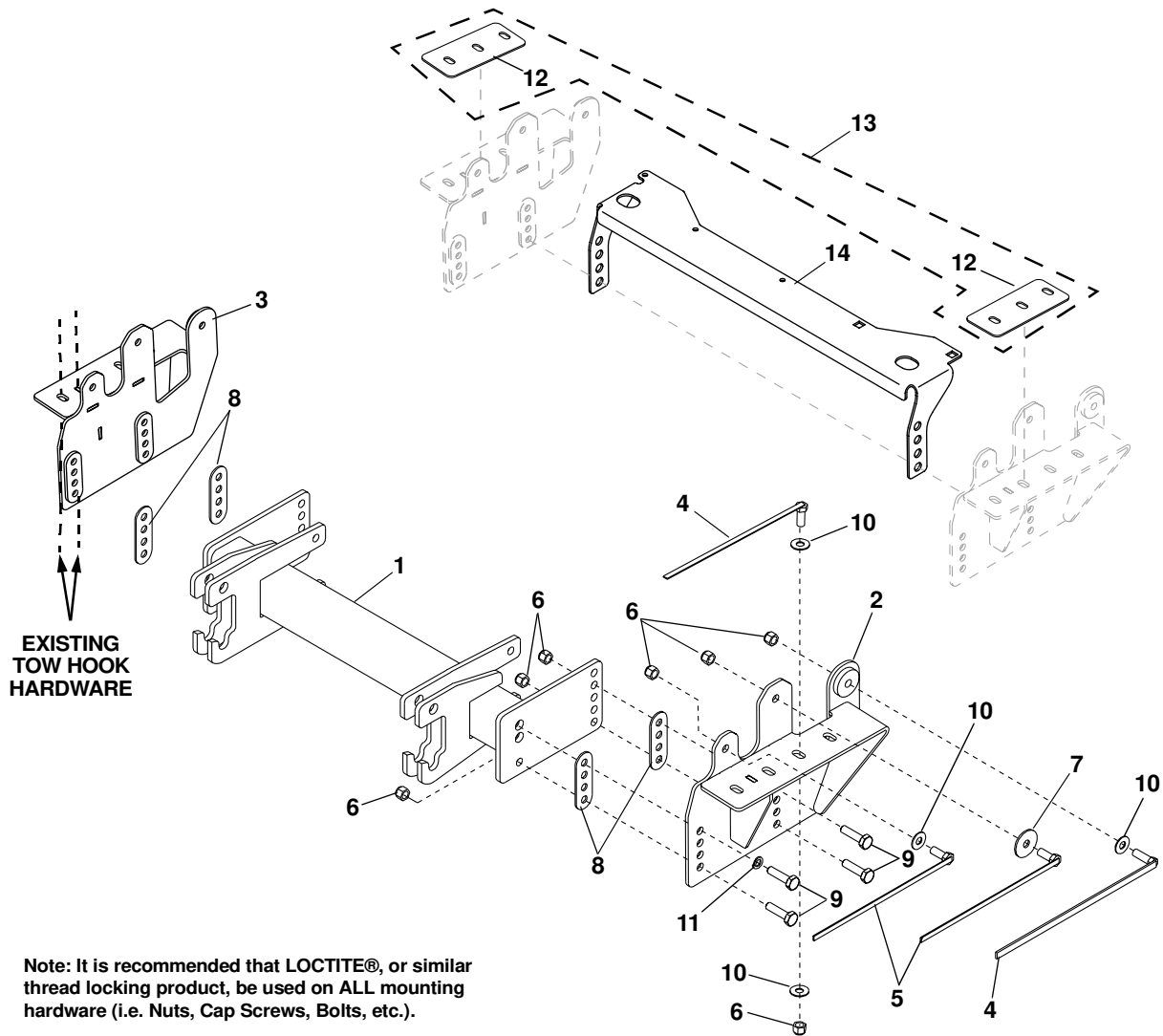

Note: It is recommended that LOCTITE®, or similar thread locking product, be used on ALL mounting hardware (i.e. Nuts, Cap Screws, Bolts, etc.).

ITEM	PART NO.	DESCRIPTION	QTY.
1	99100890	Vehicle Center Mount, 26 Series.....	1
2		Side Weldment, LH.....	1
3		Side Weldment, RH.....	1
4		Handle Bolt Weldment, 1/2"-13 x 1-1/2".....	4
5		Handle Bolt Weldment, 1/2"-13 x 1-1/4".....	2
6		LN, 1/2".....	14
7		Plate, Backing.....	2
8		Spacer, VCM, 1/8".....	4
9		HHCS, 1/2"-13 x 2".....	8
10		PW, 1/2".....	8
11		LW, 1/2".....	2
12		Plate, Shim (Used in Kit 96114192).....	2
13	96114192	Kit, Shim Plate (For 2011-2014 EcoBoost Models).....	1
14	96115839	Intercooler Support Bracket (2015 & Later EcoBoost models).....	1
15	96112507	Hardware Kit (includes items 4-11).....	1

SNO-WAY® INTERNATIONAL, INC.



Hartford, WI 53027 USA
 Website: www.snoway.com
 ©2019 Sno-Way® International