

SNO-WAY®

SNOW & ICE CONTROL EQUIPMENT

ASSEMBLY & INSTALLATION INSTRUCTIONS

FOR

**VEHICLE MOUNT KIT 99100958 USING
FOR 1500 MODELS: VEHICLE CENTER MEMBER
99100890 OR 99101443**

**FOR 2500 AND 3500 MODELS: VEHICLE CENTER MEMBER
99100892 OR 99101429**

TO FIT

1988 - 1999 CHEVROLET & GMC 1500 PICKUP 4X4
1988 - 2000 CHEVROLET & GMC 2500/3500 PICKUP 4X4
1992 - 1999 CHEVROLET 1500/2500 SUBURBAN 4X4, GMC 1500/2500
SUBURBAN 4X4, GMC 1500 YUKON 4X4
1994 - 1999 CHEVROLET TAHOE 4X4

Sno-Way®, Down Pressure® and EIS® are registered trademarks of Sno-Way International, Inc.
ProControl™, MegaBlade™, V-Wing™, E-Z Switch™, Revolution™, MaxAdjust™, SpeedLock™, and QuickJack™
are trademarks of Sno-Way International, Inc.

©2019 Sno-Way® International

97101363E



1. **THINK SAFETY, ALWAYS WEAR SAFETY GLASSES WHEN PERFORMING THE OPERATIONS PRESCRIBED IN THESE INSTRUCTIONS**
2. **READ ALL INSTRUCTIONS CAREFULLY BEFORE ATTEMPTING INSTALLATION**
3. **BEFORE BEGINNING WORK MAKE SURE TO SET PARKING BRAKE AND CHOCK WHEELS**



MINIMUM VEHICLE RECOMMENDATIONS

Heavy Duty Alternator
 Heavy Duty Battery
 Manufacturer's Snow Plow Package

NOTE: On some vehicles it may be necessary to use a form of load booster to decrease the vehicle's front suspension sag with the snow plow in place. This can be accomplished with the use of supplementary air bags, booster springs, or similar load boosting devices. Since there are different load boosting devices available, it will up to the customer/end user to decide and purchase the product to suit the application, and not the responsibility of Sno-Way International, Inc.

ASSEMBLY TOOLS NEEDED

Impact Sockets	7/16" – 1-3/8"
Impact Sockets, Metric	10mm – 18mm
Wrenches	7/16" – 1-3/8"
Wrenches, Metric	10mm - 18mm
Torque Wrench	
Rat Tail Pry Bar	
Cutting Wheel	
Touch-up Paint	

INSTALLATION NOTES

1. **Unless otherwise specified, mount all Vehicle Mount Kit Components to vehicle before tightening any hardware.**
2. **It is recommended that LOCTITE®, or similar thread locking product, be used on ALL mounting hardware (i.e. Nuts, Cap Screws, Bolts, etc.).**
3. Vehicle should be parked on a level surface with a normal vehicle load on the FRONT suspension.
4. Items in parentheses () refer to quantity required for this step. Items in parentheses with a pound sign (#) indicate the part number as found in the parts list on the last page of this document.
 Example: (2) 5/8" - 11 x 2" Cap Screws (#10).
5. It maybe necessary to relocate license plate holder. Check state and local laws for placement, if applicable.

MOUNTING INSTRUCTIONS

1. Remove the air dam from the front of the vehicle. (Retain with hardware for future use).
2. Remove the front bumper and tow hooks. Retain the bumper hardware for re-installation in Step #9. Retain the tow hooks with hardware for re-installation if the Vehicle Mount Kit is removed (*NOTE: The tow hooks cannot be re-installed once the Vehicle Mount Kit is installed*).
3. Remove the four existing bolts holding the skid plate; retain hardware for re-installation if the Vehicle Mount Kit is removed.
4. Install the Side Weldment, LH (#2) under the front frame rail of the vehicle, with the upper flange, with the three holes, located to the outside of the frame rail.
 Install (3) M14-2.00 x 50 mm Cap Screws (#13) and (3) M14 Lock Washers (#14) through the Side Weldment, LH into the existing holes in the side of the frame. (*NOTE: Be careful not to crush any wires or lines that are located inside the frame.*)
 Next, insert (1) Nut Plate (#5) into the front of the frame. Secure with (2) 1/2"-13 x 3" Cap Screws (#15) (if the tow hook can be reinstalled) or (2) 1/2"-13 x 1-1/2" Cap Screws (#7), (2) 1/2" Lock Washers (#8) and (2) 1/2" Flat Hardened Washers (#16) through the slots in the bottom of the Side Weldment, LH and into the Nut Plate.
5. Repeat Step #4 to install the Side Weldment, RH (#3).

*NOTE: If the holes for mounting the Crossmember Rear Weldment are not present in the vehicle frame, the following will be necessary:
 The Vehicle Center Member will have to be assembled to the Front Mtg Weldments, LH and RH. Then the Crossmember Rear Weldment must be assembled to the Vehicle Center Member. Finally, two 21/32 holes will have to be drilled through the frame on the horizontal portion of the frame. Using the two holes in the angled portion of the Crossmember Rear*

Weldment as a template, drill 17/32" through the angled portion of the frame rail.

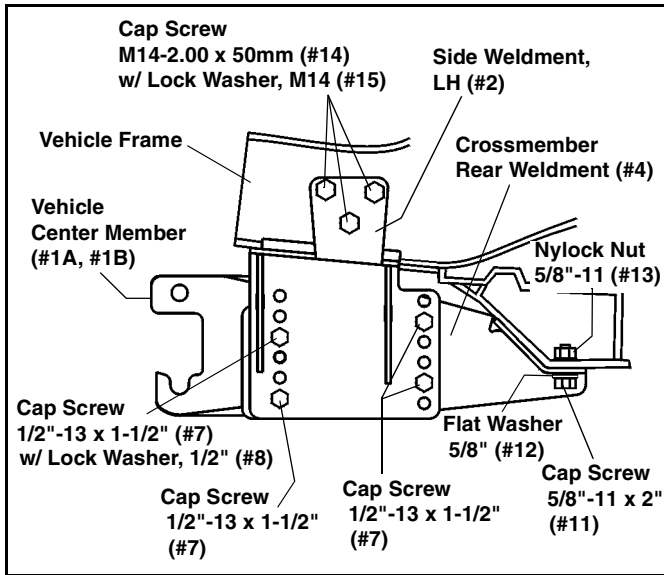

6. Position the Crossmember Rear Weldment (#4) on the vehicle frame crossmember, and attach through the two outer mounting slots with (2) 5/8"-11 x 2" Cap Screws (#10), (2) 5/8" Flat Washers (#11), and (2) 5/8" Nylock Nuts (#12). Through the drilled 17/32" holes, insert (2) Handle Bolt Weldments (#6), with (2) 1/2" Flat Washers (#16), and secure with (2) 1/2" Nylock Nuts (#9).

7. Install the Vehicle Center Member (#1);

- Attach the Vehicle Center Member (#1) to the Side Weldment LH and RH (#2 & #3), using (8) 1/2"-13 x 1-1/2" Cap Screws (#7), (2) 1/2" Lock Washers (#8) in the threaded holes, and (6) 1/2" Nylock Nuts (#9).
- Secure the Vehicle Center Member to the Crossmember Rear Weldment (#4) using (2) Spacer Plates (#17) (between the Crossmember Rear Weldment and the Vehicle Center Member lugs), (4) 1/2"-13 x 1-1/2" Cap Screws (#7) (in the top and bottom holes in the lugs), (2) 1/2"-13 x 1-1/2" Cap Screws (#7) (in one of the middle holes), and (6) 1/2"-13 Nylock Nuts (#9).

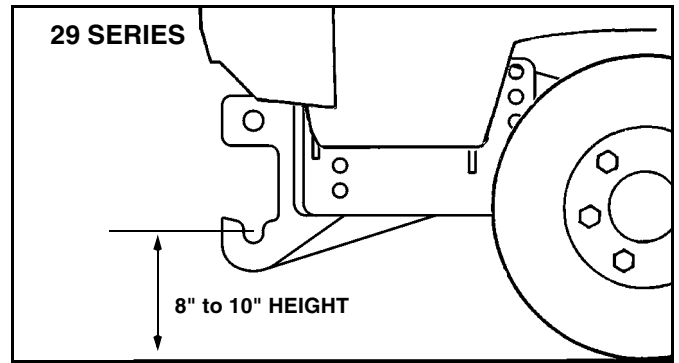

IMPORTANT: Height from the center of the lower pin slots on the Vehicle Mount Kit to the ground should be between 8" and 10" to ensure proper operation. On some vehicles, it may be necessary to use a form of load booster (See NOTE on page 1, Minimum Vehicle Recommendations).

- Using the Torque Specification Chart provided, torque all Cap Screws starting at the rear and working forward.
- Re-install the bumper. (NOTE: Modification to the fascia may be needed.)

REMEMBER After 5 to 10 hours of snowplow usage, re-torque all cap screws.

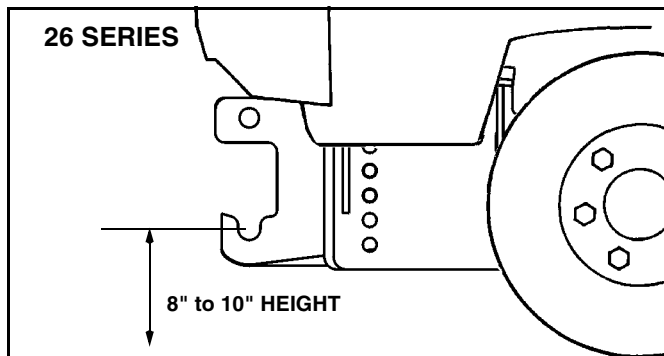

TORQUE SPECIFICATIONS FOR STANDARD MACHINE HARDWARE					
Bolt Size	GR.2 Dry	GR.5 Dry	GR.8 Dry	Metric Size	GR.8.8 Dry
1/4"	66*	9	12	M8	17
5/16"	11	17	25	M10	35
3/8"	20	30	45	M12	60
7/16"	32	50	70	M14	95
1/2"	50	75	110	M16	155
9/16"	70	110	150		
5/8"	100	150	220		
3/4"	175	260	380		
7/8"	170	430	600		
1"	250	640	900		

These torque values are to be used for all hardware. Unless otherwise specified, all torque values must meet this specification.
All torque values are in Ft.-Lbs unless otherwise stated
*In-Lbs

PARTS LIST

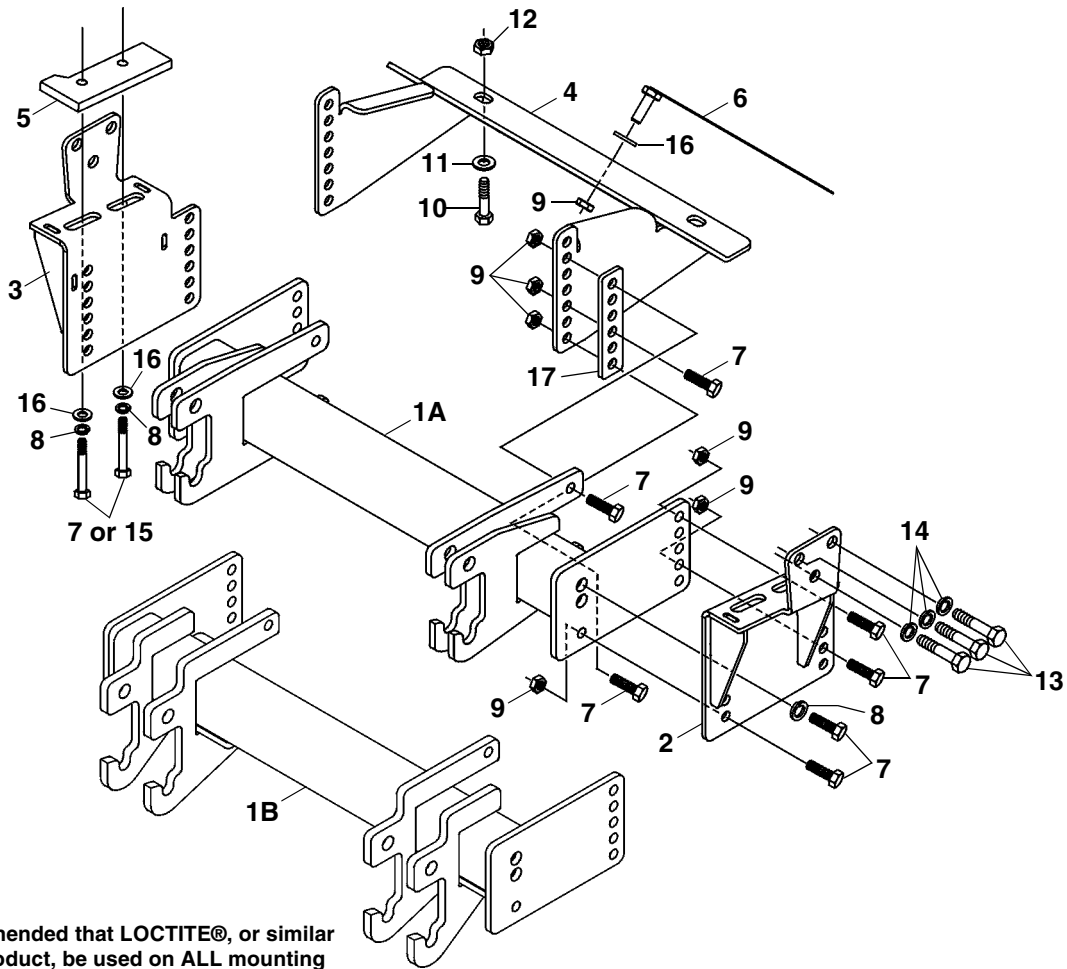

Note: It is recommended that LOCTITE®, or similar thread locking product, be used on ALL mounting hardware (i.e. Nuts, Cap Screws, Bolts, etc.).

ITEM	PART NO.	DESCRIPTION	QTY.
1A	99100890 or 99101443	Vehicle Center Member.....	1
1B	99100892 or 99101429	Vehicle Center Member.....	1
2		Side Weldment, LH.....	1
3		Side Weldment, RH.....	1
4		Crossmember Rear Weldment.....	1
5		Plate, Nut.....	2
6		Handle Bolt Weldment.....	2
7		HHCS, 1/2"-13 x 1-1/2".....	18
8		LW, 1/2".....	6
9		LN, Nylock, 1/2".....	14
10		HHCS, 5/8"-11 x 2".....	2
11		PW, 5/8".....	2
12		LN, Nylock, 5/8".....	2
13		HHCS, M14-2.00 x 50mm.....	6
14		LW, M14.....	6
15		HHCS, 1/2"-13 x 3".....	4
16		PW, 1/2" (A Wide Hardened).....	10
17		Spacer Plate.....	2
18	96111939	Kit, HDWE (Not Shown) (Includes Items 5-17).....	1

SNO-WAY® INTERNATIONAL, INC.



Hartford, WI 53027 USA
 Website: www.snoway.com
 ©2019 Sno-Way® International