

SNO-WAY®

SNOW & ICE CONTROL EQUIPMENT

ASSEMBLY & INSTALLATION INSTRUCTIONS

**MEGABLADE™ VEHICLE MOUNT KIT
99100965**

**TO FIT:
1999-LATER CHEVROLET/GMC SILVERADO/SIERRA 4X4
2500 AND 3500 PICKUP**

Sno-Way®, Down Pressure® and EIS® are registered trademarks of Sno-Way International, Inc.
ProControl™, MegaBlade™, V-Wing™, E-Z Switch™, Revolution™, MaxAdjust™, SpeedLock™, and QuickJack™
are trademarks of Sno-Way International, Inc.

©2009 Sno-Way® International

97101513B



1. **THINK SAFETY, ALWAYS WEAR SAFETY GLASSES WHEN PERFORMING THE OPERATIONS PRESCRIBED IN THESE INSTRUCTIONS**
2. **READ ALL INSTRUCTIONS CAREFULLY BEFORE ATTEMPTING INSTALLATION**
3. **BEFORE BEGINNING WORK MAKE SURE TO SET PARKING BRAKE AND CHOCK WHEELS**



MINIMUM VEHICLE RECOMMENDATIONS

Heavy Duty Alternator
 Heavy Duty Battery
 Manufacturer's Snow Plow Package

NOTE: On some vehicles it may be necessary to use a form of load booster to decrease the vehicle's front suspension sag with the snow plow in place. This can be accomplished with the use of supplementary air bags, booster springs, or similar load boosting devices. Since there are different load boosting devices available, it will up to the customer/end user to decide and purchase the product to suit the application, and not the responsibility of Sno-Way International, Inc.

ASSEMBLY TOOLS NEEDED

Drill Bits	1/4", 17/32" and 21/32"
Impact Sockets	7/16" – 1-3/8"
Impact Sockets, Metric	10mm – 18mm
Wrenches	7/16" – 1-3/8"
Wrenches, Metric	10mm - 18mm
Torque Wrench	
Rat Tail Pry Bar	
Center Punch and Hammer	
Rubber Bands	

INSTALLATION NOTES

1. **Unless otherwise specified, mount all Vehicle Mount Kit Components to vehicle before tightening any hardware.**
2. **It is recommended that LOCTITE®, or similar thread locking product, be used on ALL mounting hardware (i.e. Nuts, Cap Screws, Bolts, etc.).**
3. Vehicle should be parked on a level surface with a normal vehicle load on the FRONT suspension.
4. Items in parentheses () refer to quantity required for this step. Items in parentheses with a pound sign (#) indicate the part number as found in the parts list on the last page of this document.
 Example: (2) 5/8"-11 x 1-1/2" Cap Screws (#7).
5. It may be necessary to relocate license plate holder. Relocate under the driver's side headlight by drilling new holes in the bumper. Check state and local laws for placement, if needed.

MOUNTING INSTRUCTIONS

1. Remove the bumper with the air dam attached. Retain with hardware for replacement at the end of the installation. Typically, the front fascia or air dam of the vehicle will need to be modified to accommodate the Vehicle Mount Kit. In some cases, the fascia or air dam can be removed.
2. Remove splash shield from underneath the vehicle. It may be possible to reinstall the splash shield on the vehicle, above the Vehicle Receiver Member (#1). (If not, retain with hardware for future use.)
3. Remove the tow hooks and retain with hardware for re-installation, if plow is removed.

NOTE: Where 1/2" fasteners are used ensure that a 17/32" drill will pass through the holes. Where 5/8" fasteners are used a 21/32" drill must pass through the hole. Enlarge holes to specified size if drill will not pass through.

4. Position the rear section of the Side Weldment DS (#2) under the lip of the truck's cross frame. NOTE: Holes in Side Weldment DS (#2) should line up with existing holes in truck frame. Secure the Weldment by installing (1) Handle Bolt Weldment 5/8"-11 x 2" x 7" (#6), (1) Plate, Backing (#7), (2) 5/8" Flat Washer (#10) and (1) 5/8" Nylock Nut (#16). For the inner hole use (1) M10-1.5 x 35mm Cap Screw (#11), (1) M10 Lock Washer (#12) and (1) 1/2" Flat Washer (#13).
5. Repeat Step 4 for Side Weldment, PS (#3) installation.

6. **NOTE:** Holes referenced in this step should align with existing holes in the truck frame unless otherwise noted. Align the top inside hole of the Side Weldment, DS (#2), with the upper tow hook hole on the inside of the vehicle frame rail, and align the rear hole in the horizontal plate of the Front Mtg Weldment with the existing lower tow hook hole on the bottom of the vehicle frame rail. Install (1) Plate Backing (#7), Handle Bolt, Weldment 5/8"-11 x 2" x15" (#5) through rear hole in the Side Weldment, DS (#2) horizontal plate and bottom of the frame rail. Align U-Support, Frame Bracket (#4) into frame rail with top inside and outside holes of frame rail. Install (2) 1/2"-13 x 1-3/4" Cap Screws (#17) and (2) 1/2" Nylock Nut (#15). Locate remaining hole in outside rear of Side Weldment, DS (#2). Drill 1/4" pilot hole, and then drill to 21/32" through the side of truck frame; secure with (1) Handle Bolt, Weldment 5/8"-11 x 2" x15" (#5), (2) Flat Washers 5/8" (#10) and (1) 5/8" Nylock Nut (#16).
7. Repeat Step 5 for Side Weldment, PS (#3) installation.
8. Install the Vehicle Receiver Member (#1) found in the power pack assembly to the DS and PS Side Weldments using (8) 5/8"-11 x 1-3/4" Cap Screw (#8) and (8) 5/8" Hardened Washers (#9).
9. Using the Torque Specification Chart given, torque all bolts starting at the rear and working forward.
10. Re-install the bumper onto the vehicle, cutting facia where necessary.

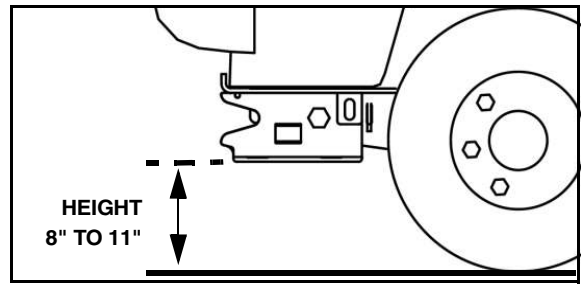

IMPORTANT: Height from the bottom of the Vehicle Receiver Member to the ground should be between 8" and 11" for proper operation.

TORQUE SPECIFICATIONS FOR STANDARD MACHINE HARDWARE					
Bolt Size	GR.2 Dry	GR.5 Dry	GR.8 Dry	Metric Size	GR.8.8 Dry
1/4"	66*	9	12	M8	17
3/8"	20	30	45	M12	60
1/2"	50	75	110	M16	155
5/8"	100	150	220		
7/8"	170	430	600		

Note: These torque values are to be used for all hardware. Unless otherwise specified, all torque values must meet this specification.
 Note: All torque values are in Ft.-Lbs unless otherwise stated
 Note: *In-Lbs

REMEMBER After 5 to 10 hours of snowplow usage, re-torque all Cap Screws!

PARTS LIST

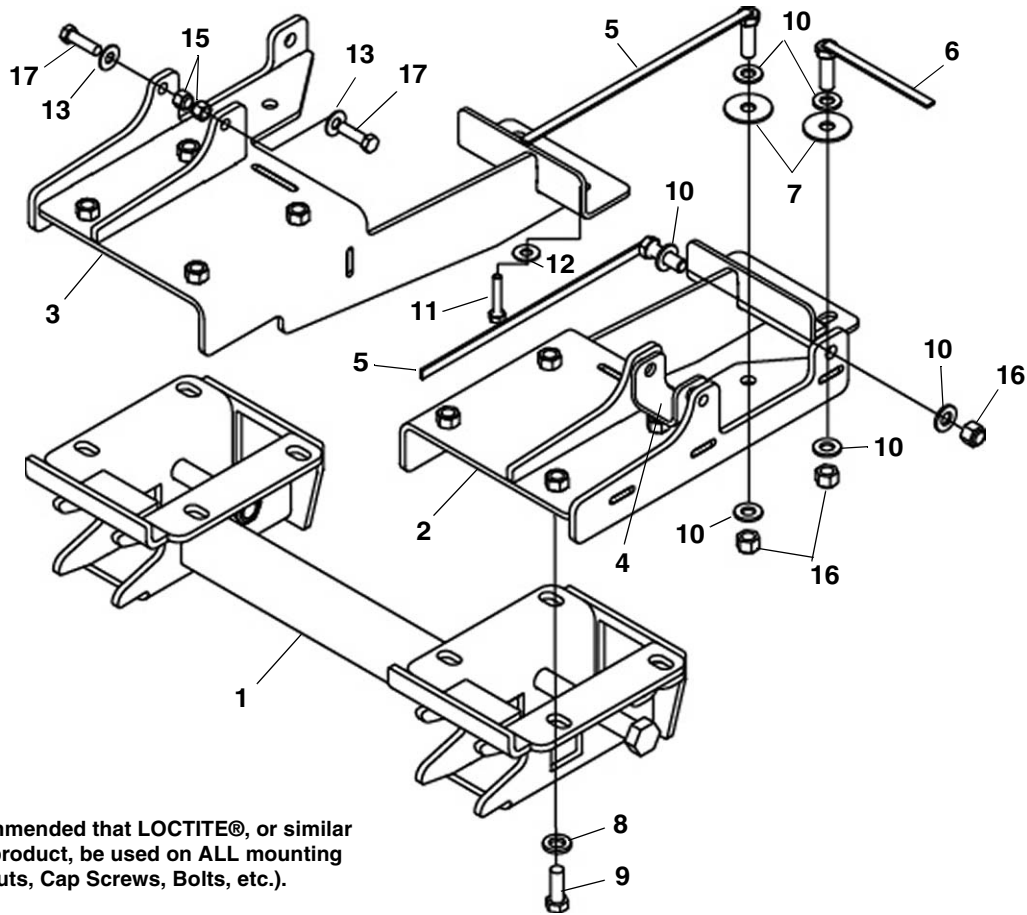

Note: It is recommended that LOCTITE®, or similar thread locking product, be used on ALL mounting hardware (i.e. Nuts, Cap Screws, Bolts, etc.).

ITEM	PART NO.	DESCRIPTION	QTY.
1	96112795*	Weldment, VRM (included in power pack).....	1
2	96111996*	Side Weldment, DS	1
3	96111997*	Side Weldment, PS	1
4	96112326*	Frame, U-Support.....	2
5	96112328*	Handle Bolt Weldment 5/8"-11 x 2" x 15"	4
6	96112347*	Handle Bolt Weldment 5/8"-11 x 2" x 7"	2
7	96112345*	Plate, Backing.....	4
8	98100445	Hex Head Cap Screw, 5/8"-11 x 1-3/4".....	8
9	98100446	Flat Washer, 5/8", .195/.170 Thick, Hardened.....	8
10	98009039	Flat Washer, 5/8"	12
11	98009060	Hex Head Cap Screw, M10-1.5 x 35mm	2
12	98100050	Lock Washer, M10	2
13	98009011	Flat Washer, 1/2"	6
14	98009012	Lock Washer, 1/2"	4
15	98009013	Lock Nut, Nylock, 1/2"-13	4
16	98009038	Lock Nut, Nylock, 5/8"-11	6
17	98100095	Hex Head Cap Screw, 1/2"-13 x 1-3/4" GR8	4

* Not Available As a Service Part

SNO-WAY® INTERNATIONAL, INC.



Hartford, WI 53027 USA
 Website: www.snoway.com
 ©2009 Sno-Way® International