

SNO-WAY®

SNOW & ICE CONTROL EQUIPMENT

ASSEMBLY & INSTALLATION INSTRUCTIONS

**MEGABLADE™ VEHICLE MOUNT KIT
99100966**

TO FIT
1988 - 2000 CHEVROLET/GMC 2500 AND 3500 PICKUP 4X4
1992 - 1999 CHEVROLET/GMC 2500 SUBURBAN 4X4

Sno-Way®, Down Pressure® and EIS® are registered trademarks of Sno-Way International, Inc.
ProControl™, MegaBlade™, V-Wing™, E-Z Switch™, Revolution™, MaxAdjust™, SpeedLock™, and QuickJack™
are trademarks of Sno-Way International, Inc.

©2009 Sno-Way® International

97101514B



1. **THINK SAFETY, ALWAYS WEAR SAFETY GLASSES WHEN PERFORMING THE OPERATIONS PRESCRIBED IN THESE INSTRUCTIONS**
2. **READ ALL INSTRUCTIONS CAREFULLY BEFORE ATTEMPTING INSTALLATION**
3. **BEFORE BEGINNING WORK MAKE SURE TO SET PARKING BRAKE AND CHOCK WHEELS**



MINIMUM VEHICLE RECOMMENDATIONS

Heavy Duty Alternator
 Heavy Duty Battery
 Manufacturers Snow Plow Package

NOTE: On some vehicles it may be necessary to use a form of load booster to decrease the vehicle's front suspension sag with the snow plow in place. This can be accomplished with the use of supplementary air bags, booster springs, or similar load boosting devices. Since there are different load boosting devices available, it will up to the customer/end user to decide and purchase the product to suit the application, and not the responsibility of Sno-Way International, Inc.

ASSEMBLY TOOLS NEEDED

Drill Bits	1/4", 17/32" and 21/32"
Impact Sockets	7/16" – 1-3/8"
Impact Sockets, Metric	10mm – 18mm
Wrenches	7/16" – 1-3/8"
Wrenches, Metric	10mm - 18mm
Torque Wrench	
Rat Tail Pry Bar	
Center Punch and Hammer	
Rubber Bands	

INSTALLATION NOTES

1. **Unless otherwise specified, mount all Subframe Components to vehicle before tightening any hardware.**
2. **It is recommended that LOCTITE®, or similar thread locking product, be used on ALL mounting hardware (i.e. Nuts, Cap Screws, Bolts, etc.).**
3. Vehicle should be parked on a level surface with a normal vehicle load on the FRONT suspension.
4. Items in parentheses () refer to quantity required for this step. Items in parentheses with a pound sign (#) indicate the part number as found in the parts list on the last page of this document.
 Example: (2) 5/8" - 11 x 2" Cap Screws (#10).
5. It may be necessary to relocate license plate holder. Check state and local laws for placement, if applicable.

MOUNTING INSTRUCTIONS

1. Remove air dam from front of vehicle. (Retain with hardware for future use if plow is removed.)
2. Remove tow hooks. (Retain with hardware for future use if plow is removed.)
3. Remove the four existing bolts holding the skid plate, retain hardware and remove corners for clearance. Retain for reinstallation in Step 9.

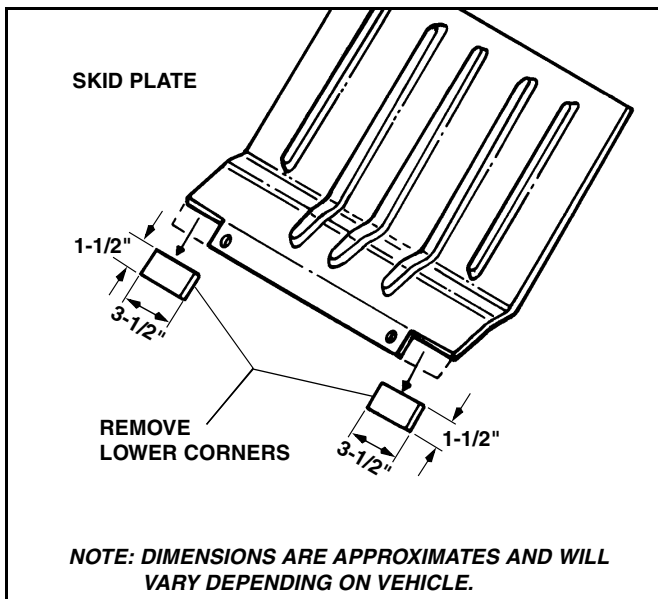

4. Position Side Weldment, DS (#2) to the front frame rails of the truck. Using the (3) M14-2.00 x 50mm Cap Screws (#12), (3) M14 Lock Washers (#13) and (3) 9/16" Flat Washers (#19) provided, bolt the Side Weldment, DS (#2) through the outside of the frame into bumper brackets (NOTE: Bracket holes may need opening to accommodate to frame).
5. Using (1) 1/2"-13 x 1-1/2" Cap Screw (#16), (2) 1/2" Flat A Hardened Washers (#14), (1) Plate Backing (#5) and (1) 1/2" Nylock Nut (#15) bolt through slot in Side Weldment, DS (#2) into truck frame rail.
6. Using (1) 5/8"-11 x 2" Cap Screw (#9), (1) 5/8" Flat Washer (#10) and (1) 5/8" Nylock Nut (#11) bolt through rear section of Side Weldment, DS (#2) and truck engine cross member.

NOTE: If holes for mounting the rear section of the weldment are not present in the engine cross member, the following steps will be necessary: While the weldment is fastened by three outer holes in front section, drill 21/32" or 17/32" holes where necessary. Drill 1/4" pilot holes before drilling final size to make drilling easier. See parts list for hole identification.

7. Using the (1) 1/2"-13 x 1-1/4 x 13" Handle Bolt Weldment (#4), (1) 1/2" Flat Washer (#18), (1) 1/2" Lock Washer (#17) and (1) 1/2"-13 Nylock Nut (#15) bolt through rear section of Weldment, DS (#2) and truck engine cross member.
8. Use the (3) front inner holes in the Side Weldment, DS (#2) as a template, then center punch and drill 1/4" pilot holes through the frame rail in each position. Drop the Side Weldment, DS (#2) out of the way and re-drill the 1/4" pilot holes to 21/32". Using the (1) Handle Bolt Weldment 5/8"-11 x 2" x 7" (#6), (2) 5/8" Flat Washers (#10) and (1) 5/8" Nylock Nut (#11) bolt through rear most hole and into truck frame. Using (2) 5/8"-11 x 2 Cap Screws (#9), (4) 5/8" Flat Washers (#10) and (2) 5/8" Nylock Nuts (#11) bolt through front inner holes.
9. Repeat Step 4 to install the Side Weldment, PS (#3). Re-install the skid plate removed in Step 3.

10. Install the Vehicle Receptacle Member (#1 - Found in Power Pack Assembly) to the DS and PS Side Weldments using (8) 5/8"-11 x 1-3/4" Cap Screws (#7), and (8) 5/8" Hardened Washers (#8).

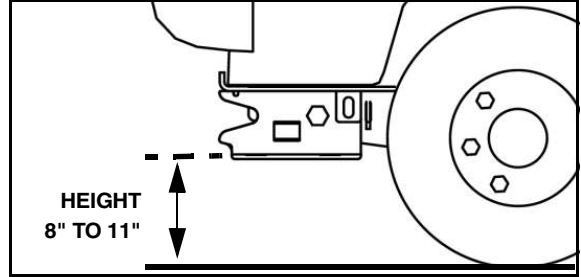

IMPORTANT: Height from the bottom of the Vehicle Receiver Member to the ground should be between 8" and 11" for proper operation.

11. Using the Torque Specification Chart provided, torque all Cap Screws starting at the rear and working forward.

REMEMBER After 5 to 10 hours of snowplow usage, re-torque all cap screws.

TORQUE SPECIFICATIONS FOR STANDARD MACHINE HARDWARE					
Bolt Size	GR.2 Dry	GR.5 Dry	GR.8 Dry	Metric Size	GR.8.8 Dry
1/4"	66*	9	12	M8	17
3/8"	20	30	45	M12	60
1/2"	50	75	110	M16	155
5/8"	100	150	220		
7/8"	170	430	600		

These torque values are to be used for all hardware. Unless otherwise specified, all torque values must meet this specification.
All torque values are in Ft.-Lbs unless otherwise stated
*In-Lbs

PARTS LIST

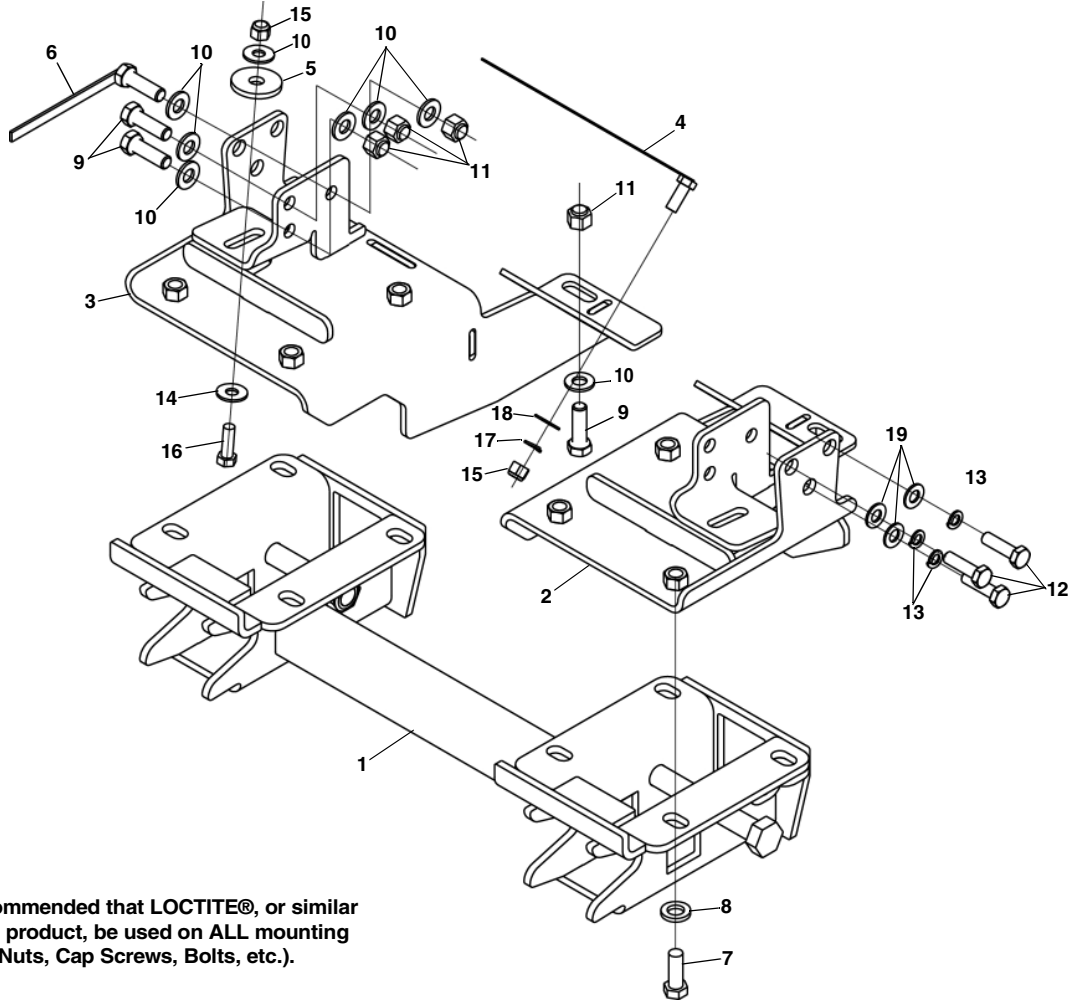

Note: It is recommended that LOCTITE®, or similar thread locking product, be used on ALL mounting hardware (i.e. Nuts, Cap Screws, Bolts, etc.).

ITEM	PART NO.	DESCRIPTION	QTY.
1	96112795*	Weldment, VRM (included in power pack)	1
2	96112027*	Side Weldment, DS	1
3	96112028*	Side Weldment, PS	1
4	96108555	Handle Bolt Weldment 1/2"-13 x 1-1/4" x13"	2
5	96112351	Plate, Backing	2
6	96112347	Handle Bolt Weldment 5/8"-11 x 2" x 7"	2
7	98100445	Hex Head Cap Screw, 5/8"-11 x 1-3/4"	8
8	98100446	Flat Washer, 5/8", .195/.170 Thick, Hardened	8
9	98009041	Hex Head Cap Screw, 5/8"-11 x 2"	6
10	98009039	Flat Washer, 5/8"	14
11	98009038	Lock Nut, Nylock, 5/8"-11	8
12	98100305	Hex Head Cap Screw, M14-2.00 x 50 mm	6
13	98100306	Lock Washer, M14	6
14	98100176	Flat Washer, 1/2" A Hardened	4
15	98009013	Lock Nut, Nylock, 1/2"-13	4
16	98009010	Hex Head Cap Screw, 1/2"-13 x 1-1/2"	2
17	98009012	Lock Washer, 1/2"	2
18	98009011	Flat Washer, 1/2"	2
19	98009131	Flat Washer, 9/16	6

* Not Available As a Service Part

SNO-WAY® INTERNATIONAL, INC.



Hartford, WI 53027 USA
 Website: www.snoway.com
 ©2009 Sno-Way® International