

# **SNO-WAY**®

**SNOW & ICE CONTROL EQUIPMENT**

## **ASSEMBLY & INSTALLATION INSTRUCTIONS**

**MEGABLADE™ VEHICLE MOUNT KIT  
99100968**

**TO FIT  
1999-2002 DODGE 2500 - 3500 PICKUP**

Sno-Way®, Down Pressure® and EIS® are registered trademarks of Sno-Way International, Inc.  
ProControl™, MegaBlade™, V-Wing™, E-Z Switch™, Revolution™, MaxAdjust™, SpeedLock™, and QuickJack™  
are trademarks of Sno-Way International, Inc.

©2009 Sno-Way® International

97101518B



1. THINK SAFETY, ALWAYS WEAR SAFETY GLASSES WHEN PERFORMING THE OPERATIONS PRESCRIBED IN THESE INSTRUCTIONS
2. READ ALL INSTRUCTIONS CAREFULLY BEFORE ATTEMPTING INSTALLATION
3. BEFORE BEGINNING WORK MAKE SURE TO SET PARKING BRAKE AND CHOCK WHEELS



### MINIMUM VEHICLE RECOMMENDATIONS

Heavy Duty Alternator  
 Heavy Duty Battery  
 Manufacturers Snow Plow Package

*NOTE: On some vehicles it may be necessary to use a form of load booster to decrease the vehicle's front suspension sag with the snow plow in place. This can be accomplished with the use of supplementary air bags, booster springs, or similar load boosting devices. Since there are different load boosting devices available, it will up to the customer/end user to decide and purchase the product to suit the application, and not the responsibility of Sno-Way International, Inc.*

### ASSEMBLY TOOLS NEEDED

Drill Bits	1/4", 17/32" and 21/32"
Impact Sockets	7/16" – 1-3/8"
Impact Sockets, Metric	10mm – 18mm
Wrenches	7/16" – 1-3/8"
Wrenches, Metric	10mm - 18mm
Torque Wrench	
Center Punch and Hammer	
Rat Tail Pry Bar	
Rubber Bands	

### INSTALLATION NOTES

1. Unless otherwise specified, mount all Subframe Components to vehicle before tightening any hardware.
2. It is recommended that LOCTITE®, or similar thread locking product, be used on ALL mounting hardware (i.e. Nuts, Cap Screws, Bolts, etc.).
3. Vehicle should be parked on a level surface with a normal vehicle load on the FRONT suspension.
4. Items in parentheses ( ) refer to quantity required for this step. Items in parentheses with a pound sign (#) indicate the part number as found in the parts list on the last page of this document.  
 Example: (2) 5/8" - 11 x 2" Cap Screws (#10).
5. It maybe necessary to relocate license plate holder. Check state and local laws for placement, if applicable.

### MOUNTING INSTRUCTIONS

*NOTE: The air dam may need to be cut for the Vehicle Mount Kit and Vehicle Center Member to be installed.*

1. On one side, remove the two front bumper bolts and the stud plate from the bumper. In the top front hole, insert a 1/2" bolt (not supplied) and tighten securely with a standard nut. One of the existing vehicle bumper bolts will replace the 1/2" bolt after the Vehicle Mount Kit is installed. Repeat this procedure for the other side.
2. Install the Front Weldment, DS (#2) as follows:

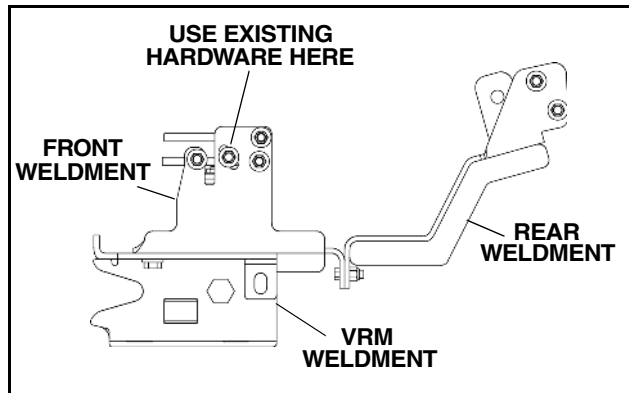

- a. Attach the Front Weldment to the outside of the frame rail, re-installing the bumper support brackets with existing hardware in the middle of the weldment. In the front most hole secure using (1) 1/2" – 13 x 1-1/2" Cap Screw (#11), (2) 1/2" Flat Washers (#9) and (1) 1/2" Nylock Nut (#10).
- b. If the two rear holes are not present, ensure that the Front Weldment, DS is parallel to ground, center punch and drill 1/4" pilot holes. Next center punch and pilot drill two holes to 1/4" in plate contacting horizontal radiator support. Drop the Front Weldment, DS out of the way and re-drill pilot holes to 17/32".

- c. Re-install Front Weldment, DS (#2), inserting through the front of the frame rail (2) Handle Bolt Weldment 1/2"-13 x 1-1/4" x 6" (#12), (2) 1/2" Flat Washers (#9) and then secure on the outside of the rail using (2) 1/2" Flat Washers (#9) and (2) 1/2" Nylock Nut (#10).

*NOTE: Note: Upon re-installation, it may be necessary to install Shim Plate (#13).*

- d. Next secure the holes in the horizontal radiator support by inserting (2) Handle Bolt Weldments 1/2"-13 x 2" x 7" (#14) with (2) 1/2" Flat Washers (#9) then secure using (2) 1/2" Flat Washers (#9) and (2) 1/2" Nylock Nut (#10).

3. Repeat Step 2a through 2d for Front Weldment, PS (#3).

4. With all mounting hardware secured loosely, install Rear Weldment, DS (#4) as follows:

- a. Attach to Front Weldment, DS (#2) using (2) 1/2" Nylock Nut (#10) and (2) 1/2" - 13 x 1-1/2" Cap Screws (#11).
- b. Position Rear Weldment, DS (#4) to contact bottom of truck frame. Center punch and pilot drill 1/4" holes using Rear Weldment, DS (#4) as a template. Drop the Rear Weldment, DS (#4) and drill to 17/32". Top hole to align with 1" hole in frame, if 1" hole is not present, one of the 17/32" holes will need to be enlarged to accommodate 1/2" U-Bolt (#8).

- c. Re-install Rear Weldment, DS (#4) adding (1) 1/2" U-Bolt (#8) (Hint: To insure the bolt doesn't fall into the frame, hold it in place with a rubber band), (2) 1/2" Flat Washers (#9) and (2) 1/2" Nylock Nuts (#10).

*NOTE: Some interference between the sway bar and the Rear Weldments may occur. If there is interference minor modifications may be needed. See Part List Page for location of possible interference.*

5. Repeat steps 4a through 4c for Rear Weldment, PS (#5).

6. Install the Vehicle Receiver Member (#1 - found in Power Pack Assembly) to the DS and PS Side Weldments using (8) 5/8"-11 x 1-3/4" Cap Screw (#6) and (8) 5/8" Hardened Washers (#7).

- 7. Using the torque specification chart provided, torque all cap screws.
- 8. Replace the 1/2" bolts installed in Step 1 with the existing bumper bolts. Tighten to manufacturers specifications.

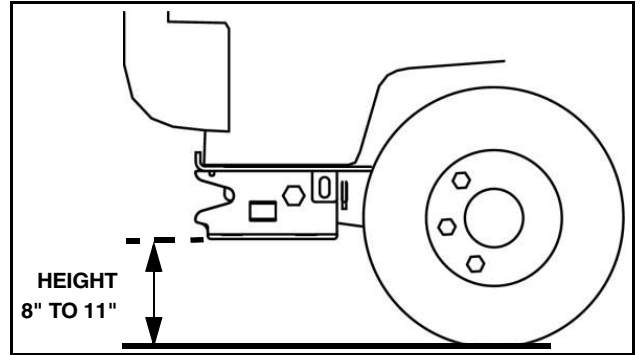

**IMPORTANT: Height from the bottom of the Vehicle Receiver Member (VRM) to the ground should be between 8" and 11" to ensure proper operation.**

TORQUE SPECIFICATIONS FOR STANDARD MACHINE HARDWARE					
Bolt Size	GR.2 Dry	GR.5 Dry	GR.8 Dry	Metric Size	GR.8.8 Dry
1/4"	66*	9	12	M8	17
3/8"	20	30	45	M12	60
1/2"	50	75	110	M16	155
5/8"	100	150	220		
7/8"	170	430	600		

Note: These torque values are to be used for all hardware. Unless otherwise specified, all torque values must meet this specification.  
Note: All torque values are in Ft.-Lbs unless otherwise stated  
Note: \*In-Lbs

**REMEMBER After 5 to 10 hours of snowplow usage, re-torque all Cap Screws!**

# PARTS LIST

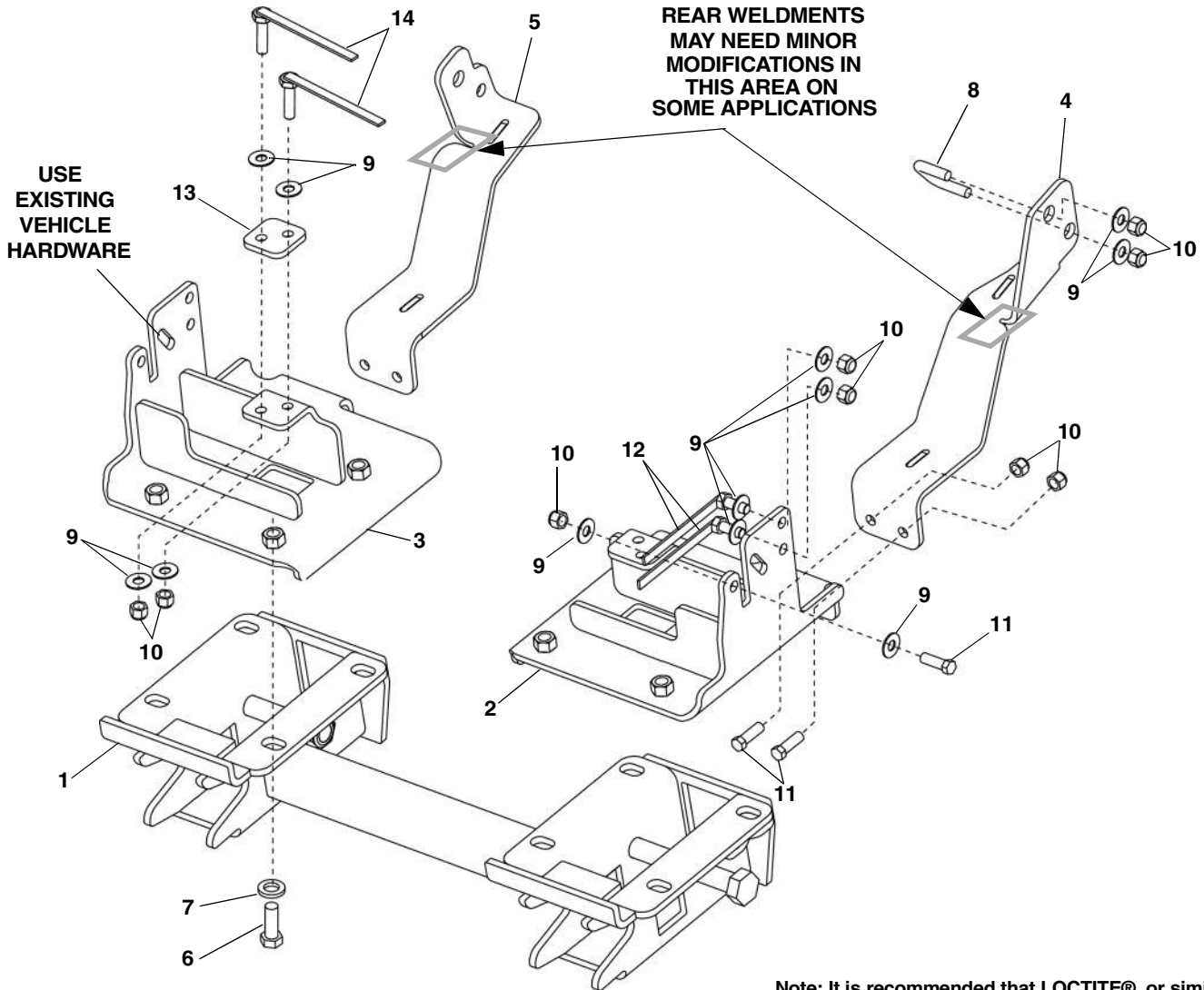

Note: It is recommended that LOCTITE®, or similar thread locking product, be used on ALL mounting hardware (i.e. Nuts, Cap Screws, Bolts, etc.).

ITEM	PART NO.	DESCRIPTION	QTY.
1	96112795*	Weldment, VRM (included in power pack).....	1
2	96111399*	Front Weldment, DS .....	1
3	96111400*	Front Weldment, PS .....	1
4	96112099*	Rear Weldment, DS .....	1
5	96112100*	Rear Weldment, PS .....	1
6	98100445	Hex Head Cap Screw, 5/8"-11 x 1-3/4".....	8
7	98100446	Flat Washer, 5/8", .195/.170 Thick, Hardened .....	8
8	98100271	U-Bolt, 1/2" .....	2
9	98009011	Flat Washer, 1/2" .....	24
10	98009013	Lock Nut, 1/2"-13, Nylock Insert .....	18
11	98009010	Hex Head Cap Screw, 1/2"-13 x 1-1/2".....	6
12	96110511	Handle Bolt Weldment 1/2"-13 x 1-1/4" x 6" .....	4
13	96112355	Plate, Shim .....	2
14	96112356	Handle Bolt Weldment, 1/2"-13 x 2" x 7" .....	4

\* Not Available As a Service Part

SNO-WAY® INTERNATIONAL, INC.



Hartford, WI 53027 USA  
 Website: www.snoway.com  
 ©2009 Sno-Way® International