

SNO-WAY®

SNOW & ICE CONTROL EQUIPMENT

ASSEMBLY & INSTALLATION INSTRUCTIONS

**MEGABLADE™ VEHICLE MOUNT KIT
99100977**

TO FIT
2008- DODGE 4500 - 5500 PICKUP 4X2 & 4X4
2008- STERLING BULLET 45, 55 4X2 & 4X4

Sno-Way®, Down Pressure® and EIS® are registered trademarks of Sno-Way International, Inc.
ProControl™, MegaBlade™, V-Wing™, E-Z Switch™, Revolution™, MaxAdjust™, SpeedLock™, and QuickJack™
are trademarks of Sno-Way International, Inc.

©2009 Sno-Way® International

97101519B



1. THINK SAFETY, ALWAYS WEAR SAFETY GLASSES WHEN PERFORMING THE OPERATIONS PRESCRIBED IN THESE INSTRUCTIONS
2. READ ALL INSTRUCTIONS CAREFULLY BEFORE ATTEMPTING INSTALLATION
3. BEFORE BEGINNING WORK MAKE SURE TO SET PARKING BRAKE AND CHOCK WHEELS



MINIMUM VEHICLE RECOMMENDATIONS

Heavy Duty Alternator
 Heavy Duty Battery
 Manufacturers Snow Plow Package

NOTE: On some vehicles it may be necessary to use a form of load booster to decrease the vehicle's front suspension sag with the snow plow in place. This can be accomplished with the use of supplementary air bags, booster springs, or similar load boosting devices. Since there are different load boosting devices available, it will up to the customer/end user to decide and purchase the product to suit the application, and not the responsibility of Sno-Way International, Inc.

ASSEMBLY TOOLS NEEDED

Drill Bits	1/4" and 21/32"
Impact Sockets	7/16" – 1-3/8"
Impact Sockets, Metric	10mm – 18mm
Wrenches	7/16" – 1-3/8"
Wrenches, Metric	10mm - 18mm
Torque Wrench	
Center Punch and Hammer	
Rat Tail Pry Bar	

INSTALLATION NOTES

1. Unless otherwise specified, mount all Subframe Components to vehicle before tightening any hardware.
2. It is recommended that LOCTITE®, or similar thread locking product, be used on ALL mounting hardware (i.e. Nuts, Cap Screws, Bolts, etc.).
3. Vehicle should be parked on a level surface with a normal vehicle load on the FRONT suspension.
4. Items in parentheses () refer to quantity required for this step. Items in parentheses with a pound sign (#) indicate the part number as found in the parts list on the last page of this document.
 Example: (2) 5/8" - 11 x 2" Cap Screws (#10).
5. It maybe necessary to relocate license plate holder. Check state and local laws for placement, if applicable.

MOUNTING INSTRUCTIONS

1. Remove the truck tow hooks and brackets by removing (2) M16 bolts and nuts (per side) from the frame rail. Retain hardware for installation in later step.

NOTE: The tow hooks must remain off the vehicle. They may be reinstalled if the Vehicle Mount Kit is removed from the vehicle.

2. Install the Side Weldment, DS (#2): Line up the holes in the Side Weldment with the holes from the tow hook bolts just removed. Secure loosely with tow hook hardware. Use the rear most hole in the Side Weldment, DS as a template, drill a 1/4" pilot hole, and then drill to 21/32". Insert (1) Handle Bolt Weldment, 5/8"-11 x 1-1/2" x 15" (#4) with (1) 5/8" Flat Washer (#7) into the frame and through the hole just drilled. Secure using (1) 5/8" Flat Washer (#7) and (1) 5/8" Nylock Nut (#8). Secure all hardware loosely.
3. Now secure the front tow hook holes with the existing tow hook hardware, but insert (2) 5/8" Lock Washers (#9) (1 per hole location) on the inside of the frame between the Side Weldment and the existing tow hook nut. Secure all hardware loosely.
4. Repeat Step #2 and #3 for the Side Weldment PS (#3).

5. Install the VRM (Vehicle Receiver Member) (#1) found in Power Pack Assembly) to the DS and PS Weldments, using (8) 5/8"-11 x 1-3/4" Cap Screws (#5) and (8) 5/8" Hardened Flat Washers (#6) securing loosely.
6. With all components in place, tighten all hardware. The mounting hardware for the VRM should be tightened first, followed by the Side weldment hardware.

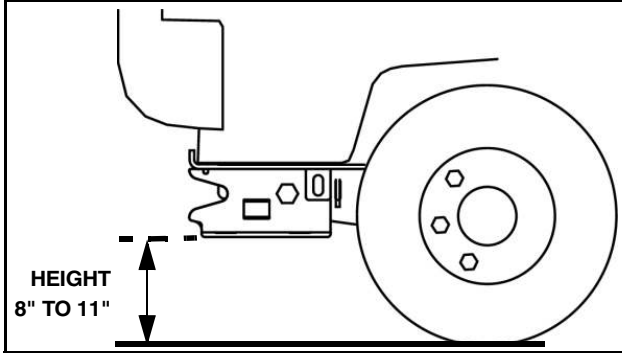

IMPORTANT: Height from the bottom of the Vehicle Receiver Member (VRM) to the ground should be between 8" and 11" to ensure proper operation.

7. Using the Torque Specification chart provided, torque all cap screws.
8. Bumper cutting shouldn't be necessary, but if you run into the black air dam, remove from vehicle or cut as necessary.

TORQUE SPECIFICATIONS FOR STANDARD MACHINE HARDWARE					
Bolt Size	GR.2 Dry	GR.5 Dry	GR.8 Dry	Metric Size	GR.8.8 Dry
1/4"	66*	9	12	M8	17
3/8"	20	30	45	M12	60
1/2"	50	75	110	M16	155
5/8"	100	150	220		
7/8"	170	430	600		

Note: These torque values are to be used for all hardware. Unless otherwise specified, all torque values must meet this specification.
 Note: All torque values are in Ft.-Lbs unless otherwise stated
 Note: *In-Lbs

REMEMBER After 5 to 10 hours of snowplow usage, re-torque all Cap Screws!

PARTS LIST

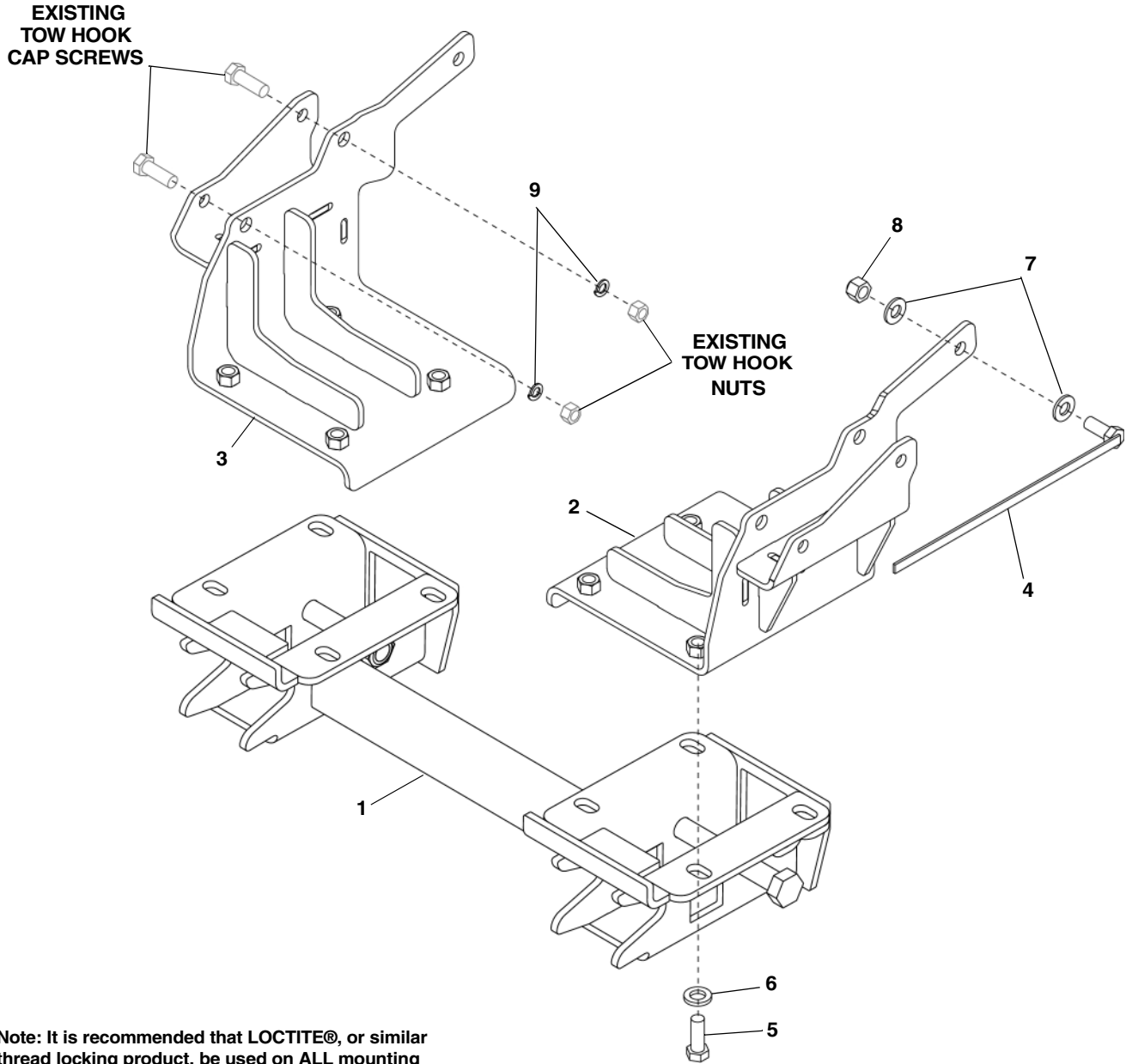

Note: It is recommended that LOCTITE®, or similar thread locking product, be used on ALL mounting hardware (i.e. Nuts, Cap Screws, Bolts, etc.).

ITEM	PART NO.	DESCRIPTION	QTY.
1	96112795*	Weldment, VRM (included in power pack).....	1
2	96112141*	Side Weldment, DS	1
3	96112140*	Side Weldment, PS	1
4	96112277*	Handle Blot Weldment, 5/8"-11 x 1-1/2" x 15"	2
5	98100445	Hex Head Cap Screw, 5/8"-11 x 1-3/4"	8
6	98100446	Flat Washer, 5/8", .195/.170 Thick, Hardened	8
7	98009039	Flat Washer, 5/8"	4
8	98009038	Lock Nut, 5/8"-11, Nylock	2
9	98009062	Lock Washer, 5/8"	4

* Not Available As a Service Part

SNO-WAY® INTERNATIONAL, INC.



Hartford, WI 53027 USA
 Website: www.snoway.com
 ©2009 Sno-Way® International