

# **SNO-WAY**®

**SNOW & ICE CONTROL EQUIPMENT**

## **ASSEMBLY & INSTALLATION INSTRUCTIONS**

**MEGABLADE™ VEHICLE MOUNT KIT  
99101012**

TO FIT  
2010 DODGE 2500 - 3500 4X4

Sno-Way®, Down Pressure® and EIS® are registered trademarks of Sno-Way International, Inc.  
ProControl™, MegaBlade™, V-Wing™, E-Z Switch™, Revolution™, MaxAdjust™, SpeedLock™, and QuickJack™  
are trademarks of Sno-Way International, Inc.

©2010 Sno-Way® International

97101635A



1. THINK SAFETY, ALWAYS WEAR SAFETY GLASSES WHEN PERFORMING THE OPERATIONS PRESCRIBED IN THESE INSTRUCTIONS
2. READ ALL INSTRUCTIONS CAREFULLY BEFORE ATTEMPTING INSTALLATION
3. BEFORE BEGINNING WORK MAKE SURE TO SET PARKING BRAKE AND CHOCK WHEELS



### MINIMUM VEHICLE RECOMMENDATIONS

Heavy Duty Alternator  
 Heavy Duty Battery  
 Manufacturers Snow Plow Package

*NOTE: On some vehicles it may be necessary to use a form of load booster to decrease the vehicle's front suspension sag with the snow plow in place. This can be accomplished with the use of supplementary air bags, booster springs, or similar load boosting devices. Since there are different load boosting devices available, it will up to the customer/end user to decide and purchase the product to suit the application, and not the responsibility of Sno-Way International, Inc.*

### ASSEMBLY TOOLS NEEDED

Drill Bits	1/4", 17/32", 21/32"
Impact Sockets	7/16" – 1-3/8"
Impact Sockets, Metric	10mm – 18mm
Wrenches	7/16" – 1-3/8"
Wrenches, Metric	10mm - 18mm
Torque Wrench	
Center Punch and Hammer	
Rat Tail Pry Bar	
Locking Pliers	

### INSTALLATION NOTES

*NOTE: Items designated "DS" refer to the Driver Side or Left Hand Side of the vehicle. Items designated "PS" refer to the Passenger Side or Right Hand Side of the vehicle.*

1. Unless otherwise specified, mount all Subframe Components to vehicle before tightening any hardware.
2. It is recommended that LOCTITE®, or similar thread locking product, be used on ALL mounting hardware (i.e. Nuts, Cap Screws, Bolts, etc.).
3. Vehicle should be parked on a level surface with a normal vehicle load on the FRONT suspension.
4. Items in parentheses ( ) refer to quantity required for this step. Items in parentheses with a pound sign (#) indicate the part number as found in the parts list on the last page of this document.  
 Example: (2) 5/8" - 11 x 2" Cap Screws (#10).
5. It maybe necessary to relocate license plate holder. Check state and local laws for placement, if applicable.

### MOUNTING INSTRUCTIONS

1. Remove the mounting hardware connecting the truck bumper to the driver side of the truck frame. Some vehicles have brackets that are bolted on and some are welded secure. If you have a version that is welded, grind area clear for sub-frame clearance (Refer to photo below).

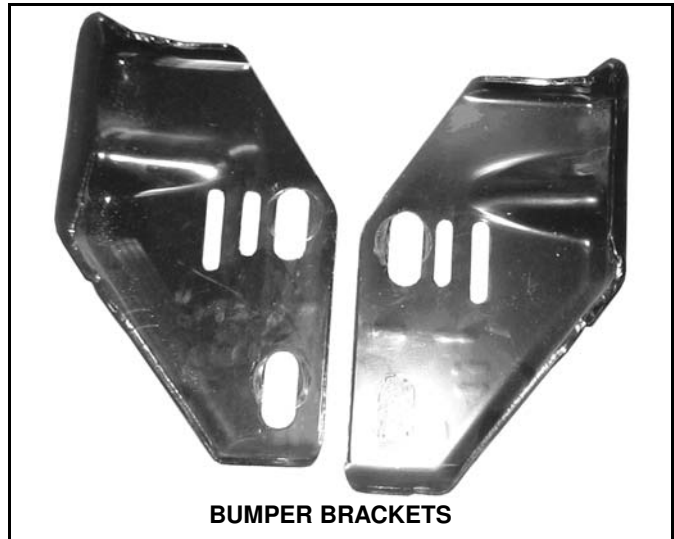

*NOTE: It may be necessary to remove radiator or inter-cooler fasteners.*

2. Place Side Weldment, DS (#2) up against the bumper bracket, aligning the two front holes in the Side Weldment, DS with the bumper mounting holes. Loosely secure (1) Side Weldment, DS (#2) to the bumper and frame using (2) 1/2" – 13 x 4-1/2" Cap Screws (#7), (4) Flat Washers, 1/2" A Wide (#11) (2 on each side of frame), and (2) 1/2" – 13 Nylock Nuts (#15). Loosely secure (2) 5/8" – 11 x 4-1/2" Cap Screws (#6), (4) Flat Washers, 5/8" B Regular (#9) (2 on each side of frame), and (2) 5/8"-11 Nylock Nut (#12) in the rear holes of the Side Weldment, DS.

3. Repeat Step 2 on the passenger side of the truck to install the Side Weldment, PS (#3).
4. Using (2) 1/2" – 13 x 1-1/2", Cap Screws (#8) Align the two rear horizontal holes of Side Weldment, DS with Rear Weldment, DS. Clamp parts together using a locking Pliers. Using the Rear Weldment, DS as a template, center punch and drill a 1/4" pilot hole where the weldment meets the truck frame. Remove Rear Weldment, DS and enlarge the 1/4" pilot hole to 21/32".
5. Loosely Attach (1) Rear Weldment, DS (#4) to Side Weldment, DS with (2) 1/2" – 13 x 1-1/2" Cap Screws (#8) and (2) 1/2" – 13 Nylock Nuts (#15). Depending on the gap between the power steering pump bracket and engine cross member, washers (not included) may be needed. These washers would be placed between items 2 & 4 (Refer to drawing at bottom of page).
6. Insert (1) 5/8" – 11 x 4-1/2" Cap Screw (#6) through (1) Flat Washer, 5/8" B Regular (#9), (1) Rear Weldment, DS (#4), and both sides of the truck frame. Then attach (1) Flat Washer, 5/8" B Wide (#10) and (1) 5/8"-11 Nylock Nut (#12) to the cap screw.
7. Repeat Steps 4, 5 and 6 on the passenger side of the truck to install the Rear Weldment, PS (#5)
8. Install the Vehicle Receiver Member (VRM)( #1) found in Power Pack Assembly to the DS and PS Side Weldments using (8) Flat Washers, 5/8", .195/.170 Thick, Hardened (#14) and (8) 5/8"-11 x 1-3/4" Cap Screws (#15), securing hardware loosely.
9. With all components in place, tighten all hardware. The mounting hardware for the VRM should be tightened first followed by the Weldment, Side hardware and finally the Weldment, Rear hardware.

**IMPORTANT: DO NOT over-tighten the upper mounting hardware for the Rear Weldments, as over-tightening could crush the frame rails!**

10. Using the torque specification chart provided, torque all cap screws.

TORQUE SPECIFICATIONS FOR STANDARD MACHINE HARDWARE					
Bolt Size	GR.2 Dry	GR.5 Dry	GR.8 Dry	Metric Size	GR.8.8 Dry
1/4"	66*	9	12	M8	17
3/8"	20	30	45	M12	60
1/2"	50	75	110	M16	155
5/8"	100	150	220		
7/8"	170	430	600		

Note: These torque values are to be used for all hardware. Unless otherwise specified, all torque values must meet this specification.  
 Note: All torque values are in Ft.-Lbs unless otherwise stated  
 Note: \*In-Lbs

**REMEMBER: After 5 to 10 hours of snowplow usage, re-torque all Cap Screws!**

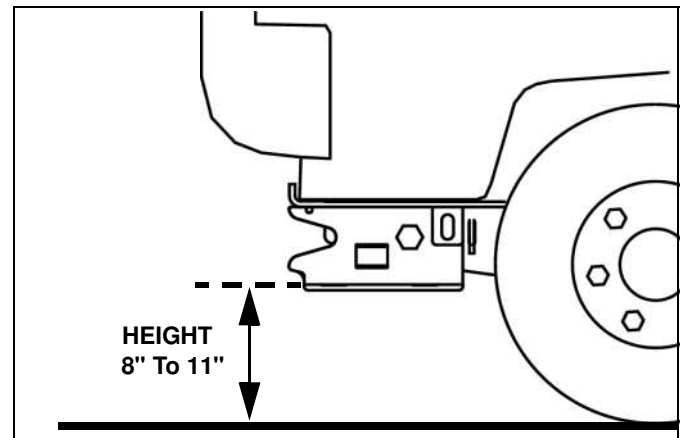

**IMPORTANT: Height from the bottom of the VRM to the ground should be between 8" and 11" to ensure proper operation.**

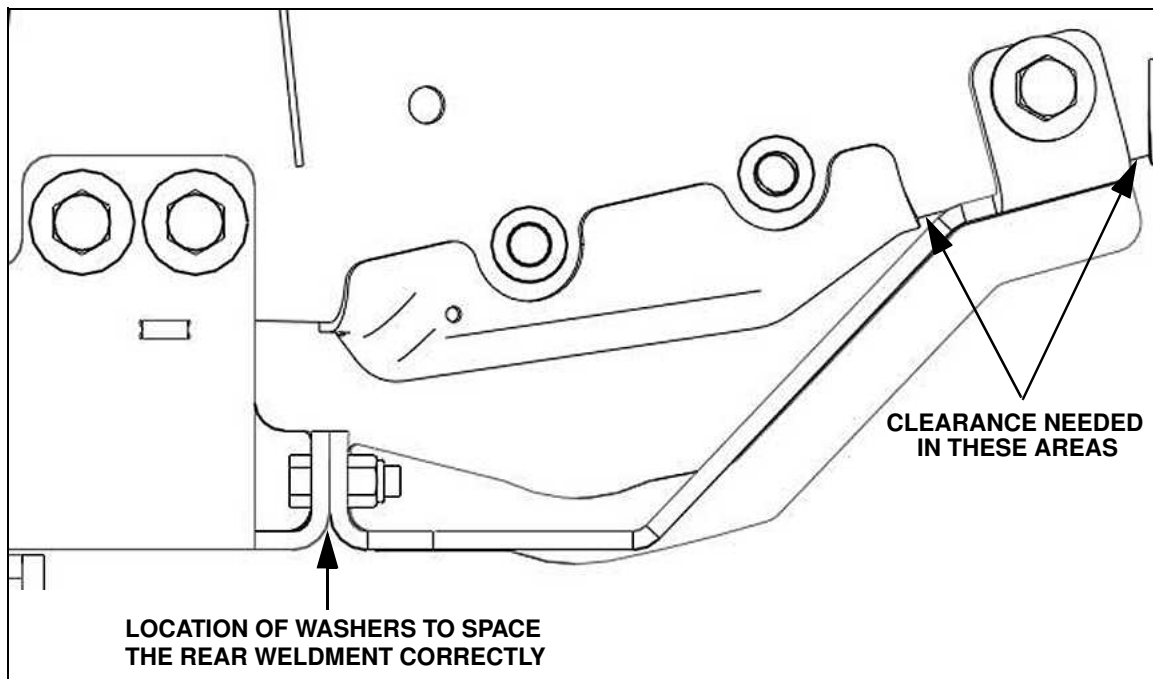

# PARTS LIST

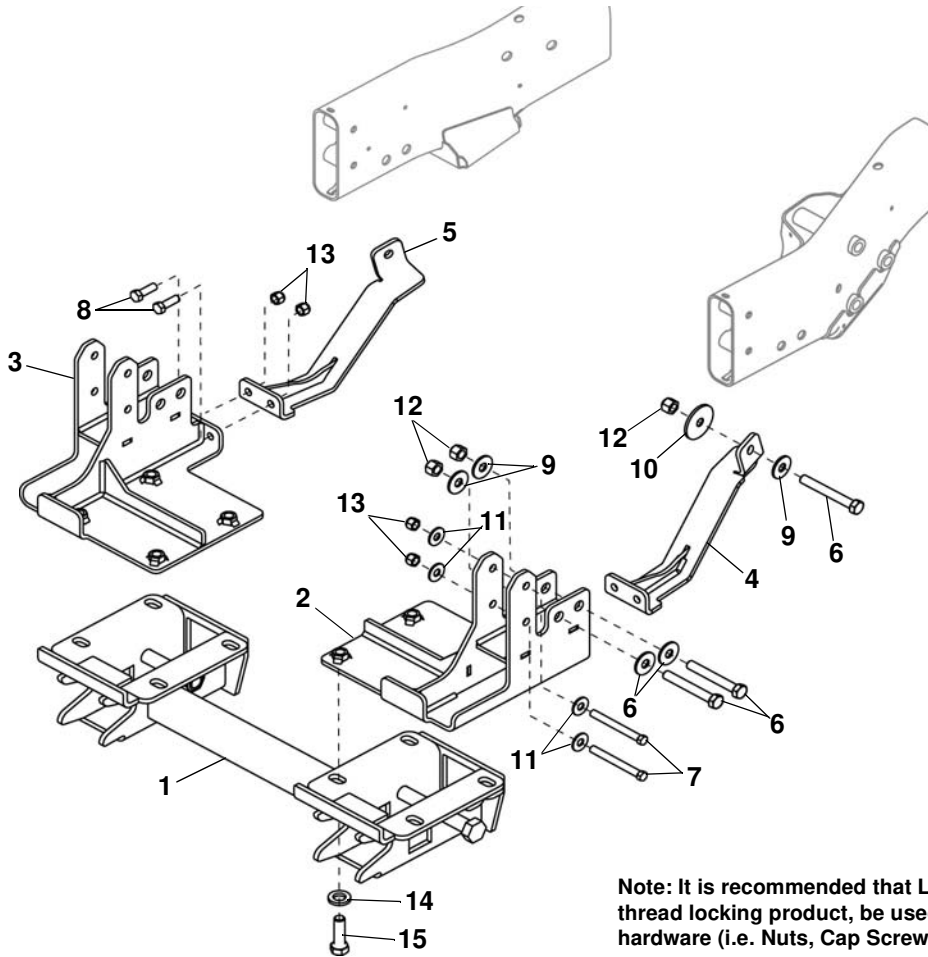

Note: It is recommended that LOCTITE®, or similar thread locking product, be used on ALL mounting hardware (i.e. Nuts, Cap Screws, Bolts, etc.).

ITEM	PART NO.	DESCRIPTION	QTY.
1	98112795*	Weldment, VRM (included in power pack) .....	1
2	96113273*	Side Weldment, DS.....	1
3	96113274*	Side Weldment, PS.....	1
4	96113373*	Rear Weldment, DS .....	1
5	96113374*	Rear Weldment, PS .....	1
6	98009111	Hex Head Cap Screw, 5/8"-11x4-1/2" .....	6
7	98009055	Hex Head Cap Screw, 1/2"-13x4-1/2" .....	4
8	98009010	Hex Head Cap Screw, 1/2"-13x1-1/2" .....	4
9	98009039	Flat Washer, 5/8", B Regular.....	10
10	98100107	Flat Washer, 5/8", B Wide .....	2
11	98100176	Flat Washer, 1/2" A Wide .....	8
12	98009038	Lock Nut, 5/8" -11, Nylock Insert.....	6
13	98009013	Lock Nut, 1/2"-13, Nylock Insert.....	8
14	98100446	Flat Washer, 5/8", .195/.170 Thick, Hardened .....	8
15	98100445	Hex Head Cap Screw, 5/8"-11x1-3/4" .....	8

\* Not Available As a Service Part

SNO-WAY® INTERNATIONAL, INC.



Hartford, WI 53027 USA  
 Website: www.snoway.com  
 ©2010 Sno-Way® International