

SNO-WAY®

SNOW & ICE CONTROL EQUIPMENT

ASSEMBLY & INSTALLATION INSTRUCTIONS

**VEHICLE MOUNT KIT 99101049
USING
VEHICLE CENTER MEMBER 99100892**

**TO FIT
2011 - 2019 CHEVROLET SILVERADO 2500/3500 4X4
2011 - 2019 GMC SIERRA 2500/3500 4X4**

Sno-Way®, Down Pressure® and EIS® are registered trademarks of Sno-Way International, Inc.
ProControl™, MegaBlade™, V-Wing™, E-Z Switch™, Revolution™, MaxAdjust™, SpeedLock™, and QuickJack™
are trademarks of Sno-Way International, Inc.

©2019 Sno-Way® International

97101654E

www.storksplows.com



1. **THINK SAFETY, ALWAYS WEAR SAFETY GLASSES WHEN PERFORMING THE OPERATIONS PRESCRIBED IN THESE INSTRUCTIONS**
2. **READ ALL INSTRUCTIONS CAREFULLY BEFORE ATTEMPTING INSTALLATION**
3. **BEFORE BEGINNING WORK MAKE SURE TO SET PARKING BRAKE AND CHOCK WHEELS**



MINIMUM VEHICLE RECOMMENDATIONS

Heavy Duty Alternator
 Heavy Duty Battery
 Manufacturer's Snow Plow Package

NOTE: On some vehicles it may be necessary to use a form of load booster to decrease the vehicle's front suspension sag with the snow plow in place. This can be accomplished with the use of supplementary air bags, booster springs, or similar load boosting devices. Since there are different load boosting devices available, it will up to the customer/end user to decide and purchase the product to suit the application, and not the responsibility of Sno-Way International, Inc.

ASSEMBLY TOOLS NEEDED

Impact Sockets	7/16" – 1-3/8"
Impact Sockets, Metric	10mm – 18mm
Wrenches	7/16" – 1-3/8"
Wrenches, Metric	10mm - 18mm
Torque Wrench	
Rat Tail Pry Bar	
Cutting Wheel	
Touch-up Paint	

INSTALLATION NOTES

1. **Unless otherwise specified, mount all Vehicle Mount Kit Components to vehicle before tightening any hardware.**
2. **It is recommended that LOCTITE®, or similar thread locking product, be used on ALL mounting hardware (i.e. Nuts, Cap Screws, Bolts, etc.).**
3. Vehicle should be parked on a level surface with a normal vehicle load on the FRONT suspension.
4. Items in parentheses () refer to quantity required for that step. Items with a pound sign (#) indicate the part number as found in the parts list on the last page of this document. Example: (2) of item #7.
5. It maybe necessary to relocate license plate holder. Relocate under the driver's side headlight by drilling new holes in the bumper.

MOUNTING INSTRUCTIONS

1. Remove the bumper with the air dam attached and disconnect the fog lights if present. Retain with hardware for replacement at the end of the installation. Typically, the front fascia or air dam of the vehicle will need to be modified or removed to accommodate the Vehicle Mount Kit.

NOTE: 2015 & Later models require more modification because of the manufacturer's integration of metal into the bumper. Details of the modification can be seen in step 14.

2. Remove splash shield from underneath the vehicle. It is possible to reinstall the splash shield on the vehicle, above the Vehicle Center Member (#1), but modifications may be needed. (Otherwise retain with hardware for future use.)
3. Remove the tow hooks and retain with hardware for re-installation.

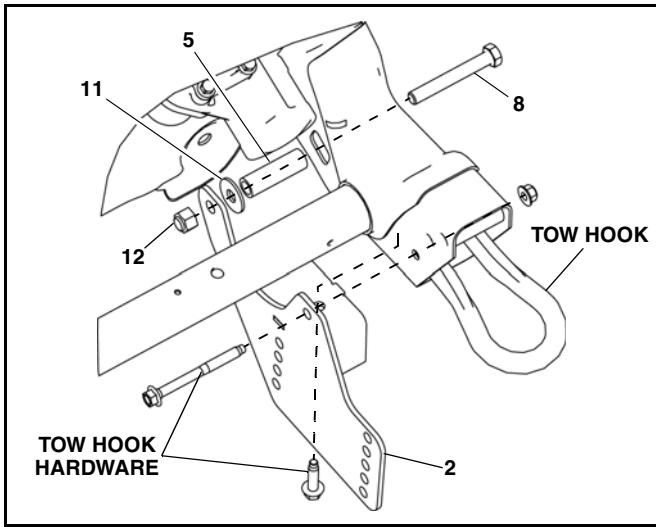

Figure 1

4. Insert (1) of item #8 through the hole opposite the square cut out on the driver side frame rail. (See Figure 1.)
5. Slide (1) of item #5 & #11 over item #8, while item #8 is within the truck frame
6. Loosely attach item #2 to item #8 using Item #12.
7. Fit item #2 to the driver side frame rail by aligning the hole and slot of item #2 to the holes from which the tow hook hardware was removed.
8. Loosely attach the tow hook and item #2 with the previously removed tow hook hardware.
9. Repeat steps 4 through 8 to install item #3 on the passenger side.

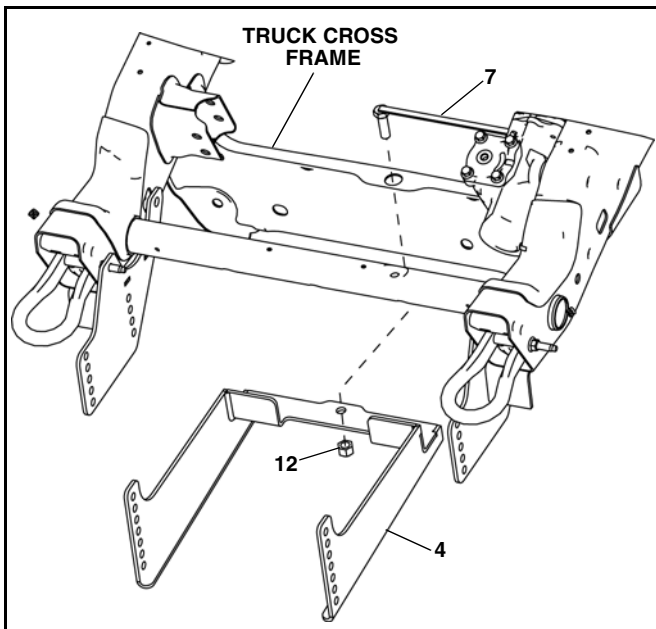

Figure 2

10. Position item #4 under the truck's cross frame. Insert item #7 into the cross frame through the top and into the hole located in the middle. Slide item #4 over item #7 and loosely attach with item #12. (See Figure 2.)

NOTE: The hole that item #7 slides through may be slightly blocked by the splash shield and may need to be drilled or ground open to allow the bolt to pass through.

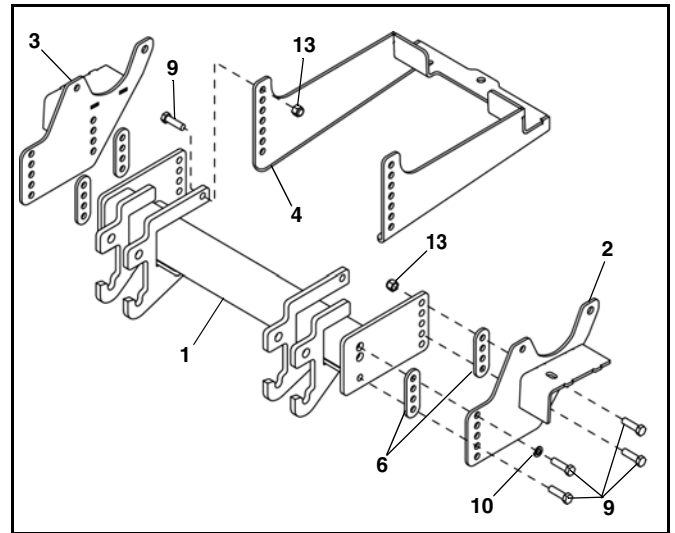

Figure 3

11. Attach item #1 to item #2 & #3, using (8) of item #9, (4) of item #6, (2) of item #10, and (6) of item #13. (See Figure 3.)
12. Secure item #1 to item #4 using (4) of item #9 and (4) of item #13.
13. Using the Torque Specification Chart (See Page 6), torque all bolts starting at the rear and working forward.
14. If installing on a 2014 or earlier model, skip to step 15. (See Page 6.)

If installing on a 2015 and later model, further modifications to the bumper are required and are different between the Sierra and Silverado models. (See page 3 for Sierra or page 5 for Silverado models.)

FOR 2015 & LATER GMC SIERRA PICKUPS

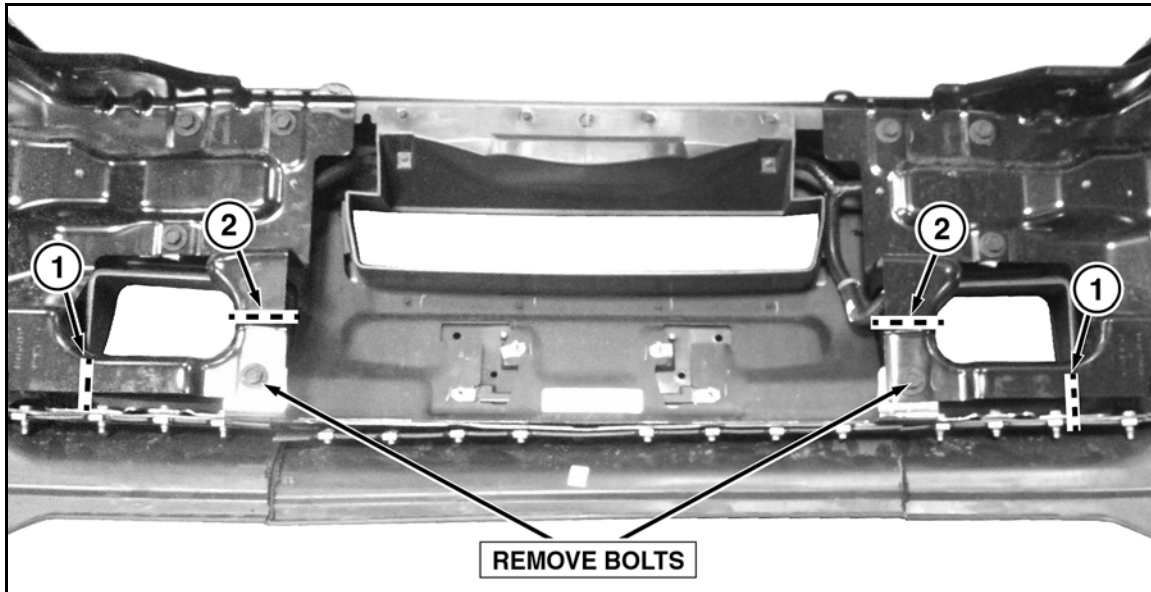

Figure 4

- A. Cut #1 at the bottom of the radius of the metal. (See Figure 4.)
- B. Cut #2 just above the horizontal bend, then remove the bolts holding the sections of metal in place. (See Figure 4.)

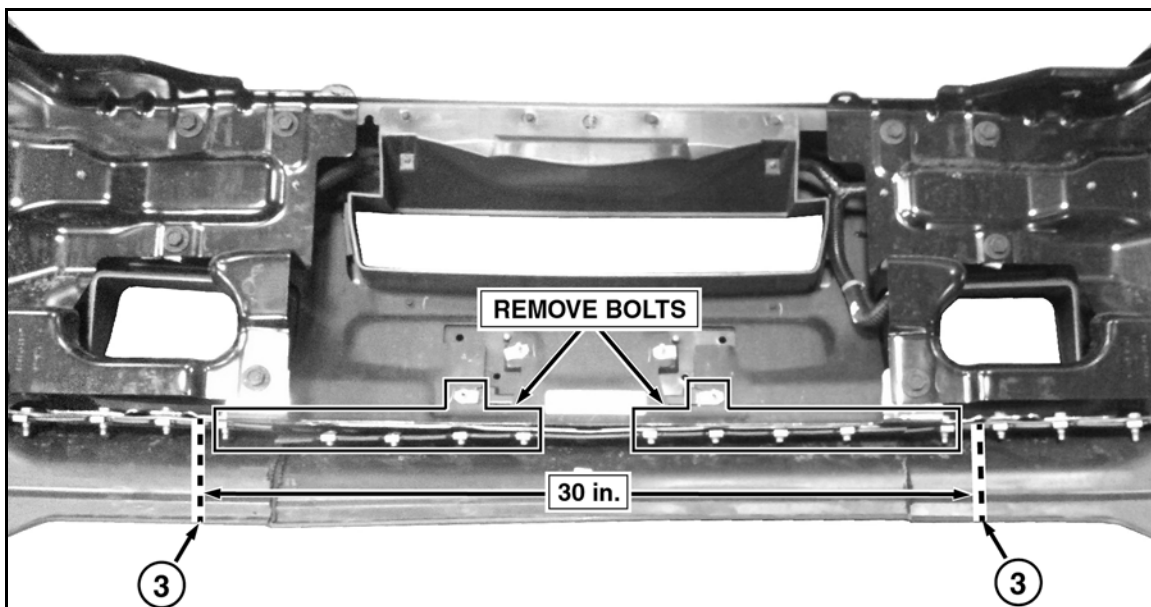

Figure 5

- C. Cut #3 is 30 in. wide on center. Cut straight up the lower plastic valance, then cut into only the metal that that lower valance is bolted to. Then remove the 12 bolts holding the plastic portion of the bumper into integrated metal. (See Figure 5.)

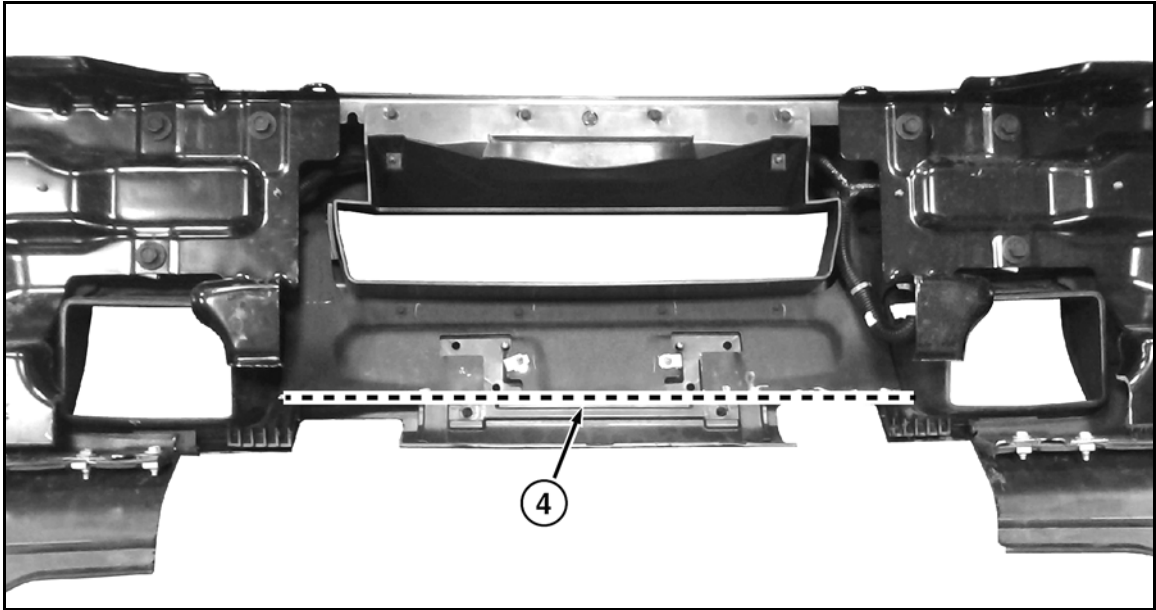

Figure 6

- D. Cut #4 - Be sure to cut #4 only into the integrated metal and not the plastic portion of the bumper (See Figure 6).
 Note: For picture clarity, Step F is already shown completed in Figure 6.
- E. Dress all exposed cut metal edges on the bumper with touch-up paint to prevent corrosion.

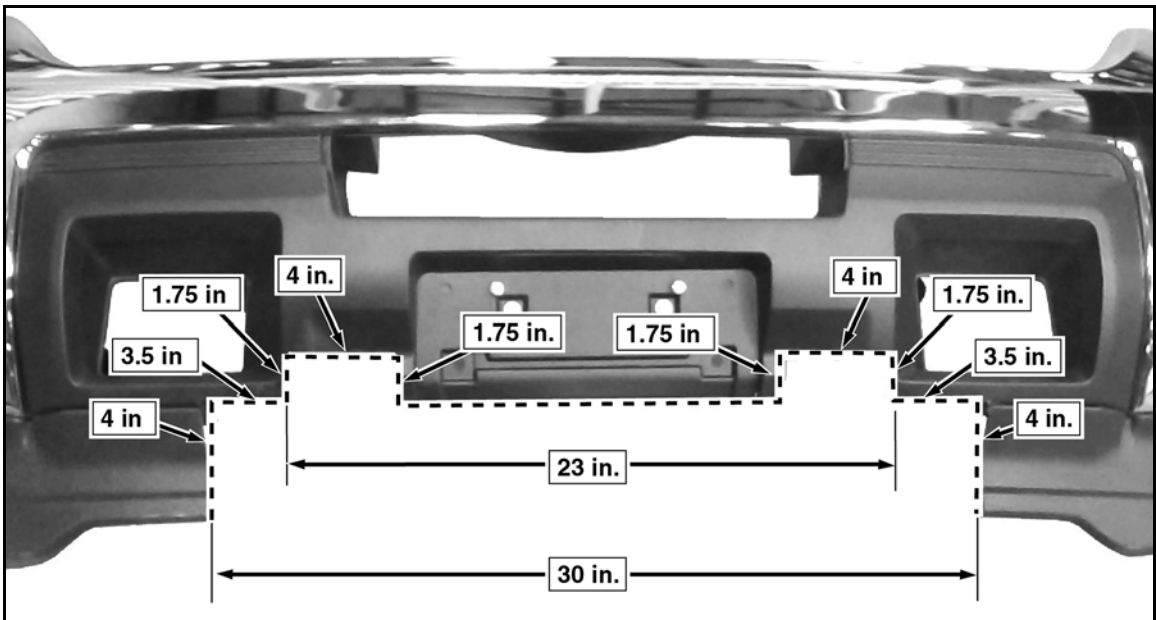

Figure 7

- F. Steps A-E removes the interfering integrated metal in the bumper. The remaining plastic can be modified and cut as usual for the VMK. See Figure 7 for reference of how to cut the plastic for setting the VCM to 10 in. Keep in mind height dimensions 4 in. & 1.75 in. may vary depending on the ride height of the truck.

FOR 2015 & LATER CHEVEROLET SILVERADO PICKUPS

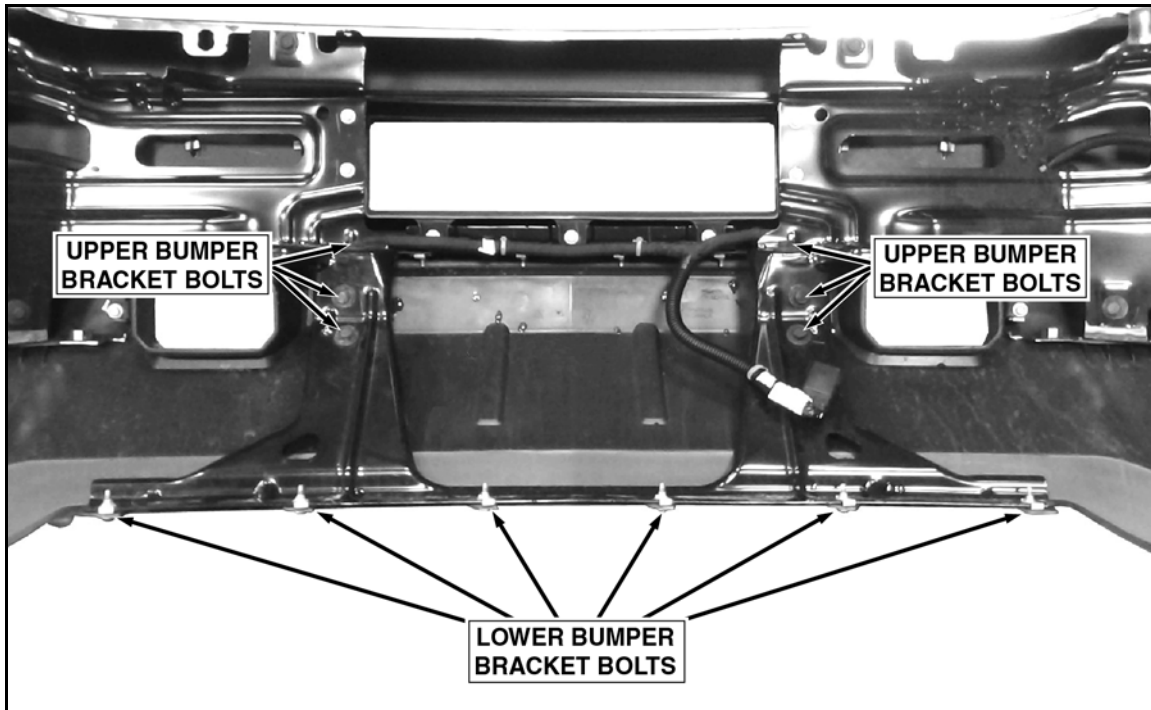

Figure 8

G. Remove 6 bolts (3 each side) holding the upper bumper bracket to the main bumper flanges. (See Figure 8.)

H. Remove 6 bolts holding the lower bumper bracket to the lower plastic portion of the bumper. (See Figure 8.)

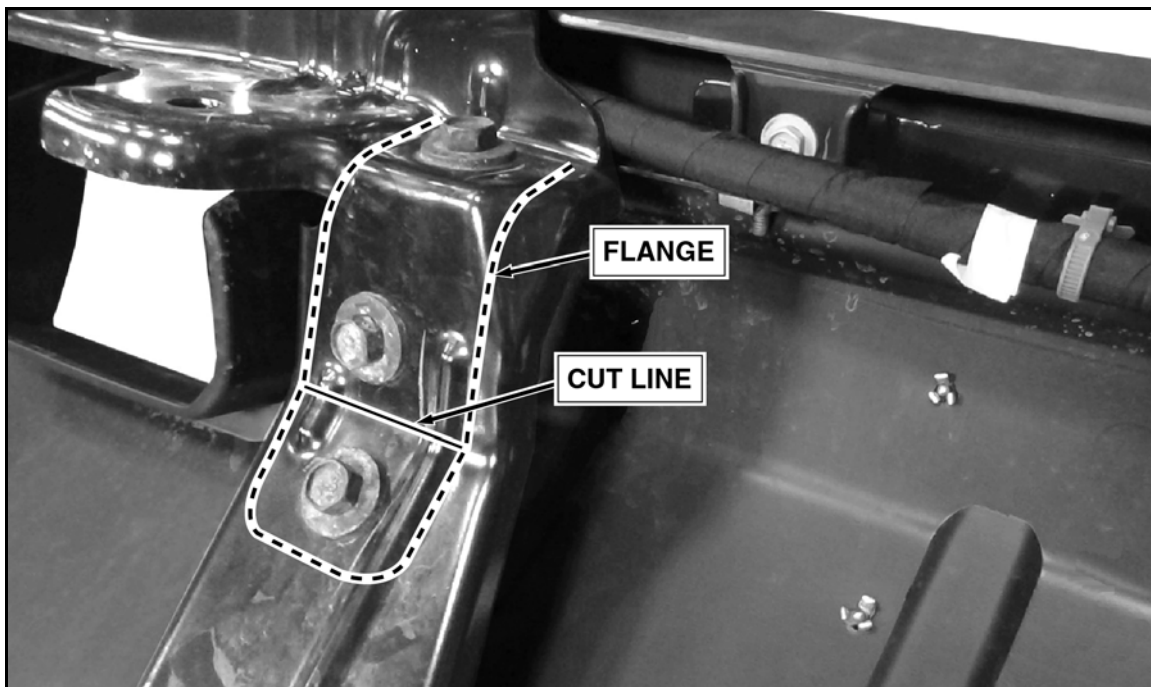

Figure 9

I. Depending on the height at which the VCM is set, the lower portion of both main bumper flanges (shown outlined above) may need to be cut. If cutting is required, cut the lower portion of each flange as shown above. (See Figure 9.)

J. Dress all exposed cut metal edges on the bumper with touch-up paint to prevent corrosion.

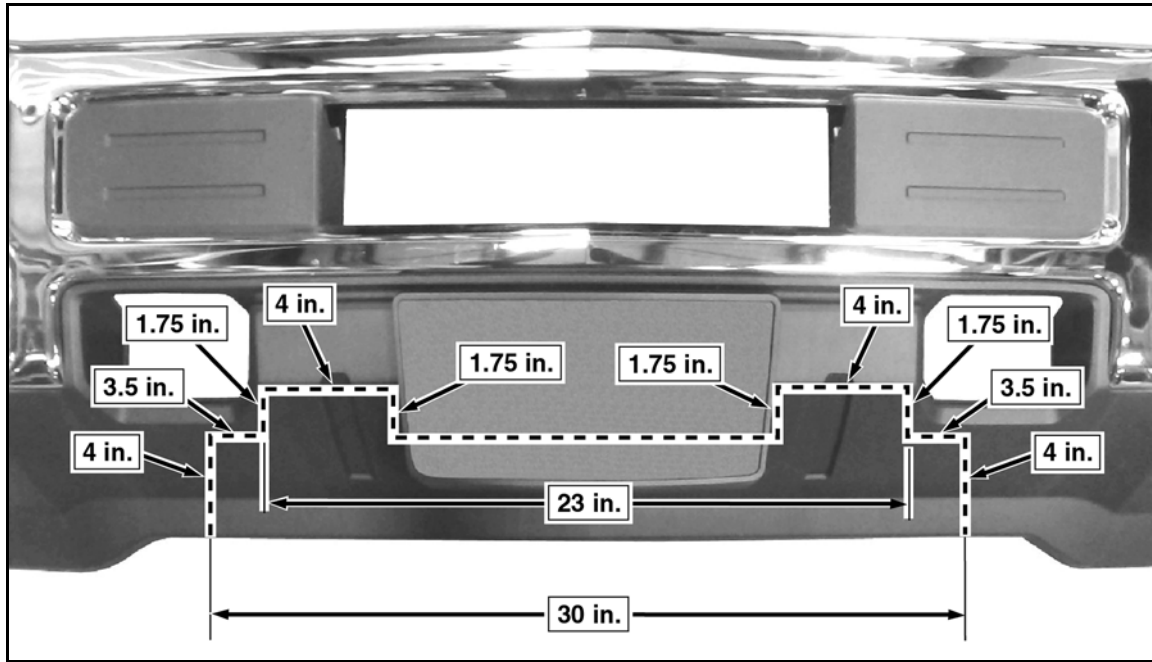

Figure 10

K. Steps G-J removes the interfering bumper bracket from the rear of the bumper. The remaining plastic can be modified and cut as usual for the VMK. See Figure 10 for reference of how to cut the plastic for setting the VCM to 10 in. Keep in mind height dimensions 4 in. & 1.75 in. may vary depending on the ride height of the truck.

15. Re-install the bumper onto the vehicle and reconnect the fog lights if present.

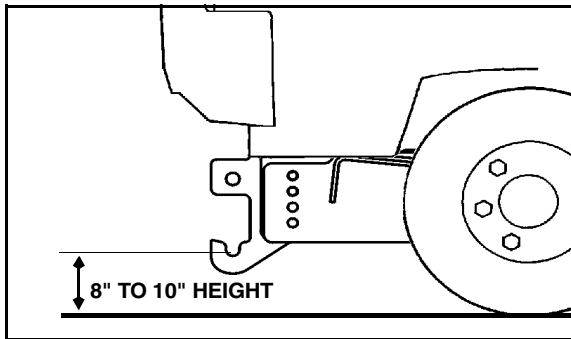

Figure 11

IMPORTANT: Height from the bottom of the lower pin slots on the Vehicle Mount Kit to the ground should be between 8" and 10" for proper operation.

16. Using the Torque Specification Chart below, torque all bumper bolts.

TORQUE SPECIFICATIONS FOR STANDARD MACHINE HARDWARE					
Bolt Size	GR.2 Dry	GR.5 Dry	GR.8 Dry	Metric Size	GR.8.8 Dry
1/4"	66*	9	12	M8	17
5/16"	11	17	25	M10	35
3/8"	20	30	45	M12	60
7/16"	32	50	70	M14	95
1/2"	50	75	110	M16	155
9/16"	70	110	150		
5/8"	100	150	220		
3/4"	175	260	380		
7/8"	170	430	600		
1"	250	640	900		

Note: These torque values are to be used for all hardware. Unless otherwise specified, all torque values must meet this specification.
 Note: All torque values are in Ft.-Lbs unless otherwise stated
 Note: *In-Lbs

REMEMBER After 5 to 10 hours of snowplow usage, re-torque all Cap Screws!

PARTS LIST

Note: It is recommended that LOCTITE®, or similar thread locking product, be used on ALL mounting hardware (i.e. Nuts, Cap Screws, Bolts, etc.).

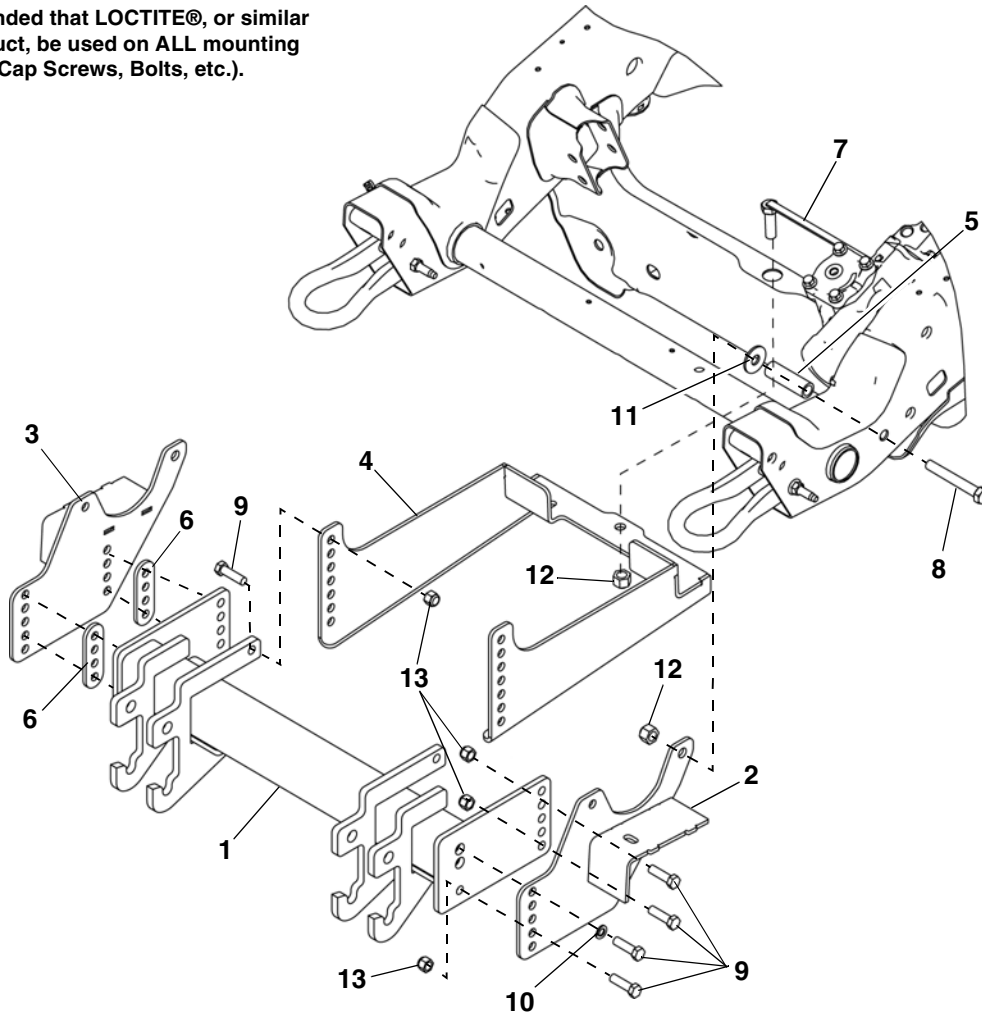

ITEM	PART NO.	DESCRIPTION	QTY.
1	99100892	Vehicle Center Member	1
2		Front Mtg Weldment, DS	1
3		Front Mtg Weldment, PS	1
4		Crossmember Rear Weldment	1
5		Spacer, Tube	2
6		Spacer, VCM, 1/4"	4
7		Handle Bolt Weldment, 5/8"-11 x 2"	1
8		HHCS, 5/8"-11 x 5"	2
9		HHCS, 1/2"-13 x 1-3/4"	12
10		LW, 1/2"	2
11		PW, 5/8", B Regular	2
12		LN, 5/8"-11, Nylock Insert	3
13		LN, 1/2"-13, Nylock Insert	10
14	96113544	Kit, HDWE (Not Shown) (Includes Items 5-13)	1

SNO-WAY® INTERNATIONAL, INC.



Hartford, WI 53027 USA
 Website: www.snoway.com
 ©2019 Sno-Way® International