



**Assembly
&
Installation Instructions**

**FOR
VEHICLE MOUNT KIT 99101050
AND
VEHICLE CENTER MEMBER 99100891**

**TO FIT
2010 DODGE 2500 - 3500 4x4**

©2012 Sno-Way® International

97101645B



1. **THINK SAFETY, ALWAYS WEAR SAFETY GLASSES WHEN PERFORMING THE OPERATIONS PRESCRIBED IN THESE INSTRUCTIONS**
2. **READ ALL INSTRUCTIONS CAREFULLY BEFORE ATTEMPTING INSTALLATION**
3. **BEFORE BEGINNING WORK MAKE SURE TO SET PARKING BRAKE AND CHOCK WHEELS**



MINIMUM VEHICLE RECOMMENDATIONS

Heavy Duty Alternator
 Heavy Duty Battery
 Manufacturer's Snow Plow Package

NOTE: On some vehicles it may be necessary to use a form of load booster to decrease the vehicle's front suspension sag with the snow plow in place. This can be accomplished with the use of supplementary air bags, booster springs, or similar load boosting devices. Since there are different load boosting devices available, it will up to the customer/end user to decide and purchase the product to suit the application, and not the responsibility of Sno-Way International, Inc.

ASSEMBLY TOOLS NEEDED

Drill Bits	1/4", 17/32", 21/32"
Impact Sockets	7/16" - 1-3/8"
Metric Sockets	10mm - 18mm
Wrenches	7/16" - 1-3/8"
Metric Wrenches	10mm - 18mm
Torque Wrench	
Center Punch and Hammer	
Hacksaw	
Clamping Devices ("C" or bar type)	
Rat Tail Pry Bar	

INSTALLATION NOTES

1. **Unless otherwise specified, mount all Vehicle Mount Kit Components to vehicle before tightening any hardware.**
2. **It is recommended that LOCTITE®, or similar thread locking product, be used on ALL mounting hardware (i.e. Nuts, Cap Screws, Bolts, etc.).**
3. Vehicle should be parked on a level surface with a normal vehicle load on the FRONT suspension.
4. Items in parentheses () refer to quantity required for this step. Items in parentheses with a pound sign (#) indicate the part number as found in the parts list on the last page of this document.
 Example: (2) 1/2" Lock Washers (#9).
5. It maybe necessary to relocate license plate holder. Check state and local laws for placement, if needed.

MOUNTING INSTRUCTIONS

1. Remove the mounting hardware connecting the truck bumper to the driver side of the truck frame. Place the Front Mtg Weldment, DS (#3) up against the bumper bracket, aligning the two front holes in the Front Mtg Weldment with the bumper mounting holes. Temporarily secure using (2) 1/2"-13 x 4-1/2" Cap Screws (#15), (4) 1/2" Flat Washers (#16) (2 on each side of the frame), and (2) 1/2"-13 Nylock Nuts (#11). Using the bottom hole in the Front Mtg Weldment as a template, center punch and drill 17/32" holes. **(DO NOT drill through both sides of the frame rail.)** Repeat the process on the passenger side of the truck to install the Front Mtg Weldment, PS (#2).
2. Remove both Front Mtg Weldments, DS (#3) and PS (#2), and the truck bumper. Re-align the Front Mtg Weldment, DS (#3), with the previously drilled holes in the driver side of the frame. For both DS and PS Weldment installation perform the following steps:

Position Shim Plate (#7) between the bottom of the truck frame and the Front Mtg Weldment. Install a 1/2"-13 x 1-1/2" Cap Screw (#9), and 1/2" Lock Washer (#10), through the Front Mtg Weldment, Shim Plate and the truck frame, securing loosely using a Wire Nut (#8) inserted from the front end of the truck frame rail.

Place second Shim Plate (#6) between the rear mounting hole in frame and the Front Mtg Weldment. Secure loosely using a 5/8"-11 x 4-1/2" Cap Screw (#17), and 5/8" Flat Washer (#13), through the Front Mtg Weldment, Shim Plate and the truck frame. Secure loosely using a 5/8" Flat Washer (#13) and 5/8"-11 Nylock Nut (#14). Re-install the truck bumper using the hardware from step #1.

3. Install the Vehicle Center Member (#1) between the Front Mtg Weldments (#2 and #3) using (8) 1/2"-13 x 1-1/2" Cap Screws (#9), (2) 1/2" Lock Washers (#10) on Cap Screws used in the threaded holes, and (6) 1/2"-13 Nylock Nuts (#11).
4. Assemble the Rear Mtg Weldments, DS (#4) and PS (#5), onto the rear most line of holes on the Front Mtg Weldments (#2 and #3). Then secure each side using (2) 1/2"-13 x 1-1/2" Cap Screws (#9), and (2) 1/2"-13 Nylock Nuts (#11). The rear mount supports of the Rear Mtg Weldments should contact the outside and bottom of the truck frame. If necessary adjust the vertical mounting location of the Rear Mtg Weldments on the Front Mtg Weldments for proper alignment. With the Rear Mtg Weldments in position, use the rear mounting holes as a template, then center punch and drill 1/4" pilot holes through one side of the frame rail in each location. Drop the Rear Mtg Weldments out of the way and re-drill the pilot holes to 21/32". Install Rear Mtg Weldments, DS (#4) and PS (#5), using (1) 5/8"-11 x 4" Cap Screw (# 15), (1) 5/8" Flat Washer (#13), and (1) 5/8" Nylock Nut (#14), per side.

5. With all components in place, tighten all hardware.
The mounting hardware for the Front Mtg Weldments should be tightened first then the remaining hardware.
(DO NOT over-tighten the upper mounting hardware for the Rear Mtg Weldments, as over-tightening could crush the frame rails!)
6. Using the torque specification chart provided, torque all cap screws.

TORQUE SPECIFICATIONS FOR STANDARD MACHINE HARDWARE					
Bolt Size	GR.2 Dry	GR.5 Dry	GR.8 Dry	Metric Size	GR.8.8 Dry
1/4"	66*	9	12	M8	17
5/16"	11	17	25	M10	35
3/8"	20	30	45	M12	60
7/16"	32	50	70	M14	95
1/2"	50	75	110	M16	155
9/16"	70	110	150		
5/8"	100	150	220		
3/4"	175	260	380		
7/8"	170	430	600		
1"	250	640	900		

Note: These torque values are to be used for all hardware. Unless otherwise specified, all torque values must meet this specification.
Note: All torque values are in Ft.-Lbs unless otherwise stated
Note: *In-Lbs

REMEMBER After 5 to 10 hours of snowplow usage, re-torque all Cap Screws!

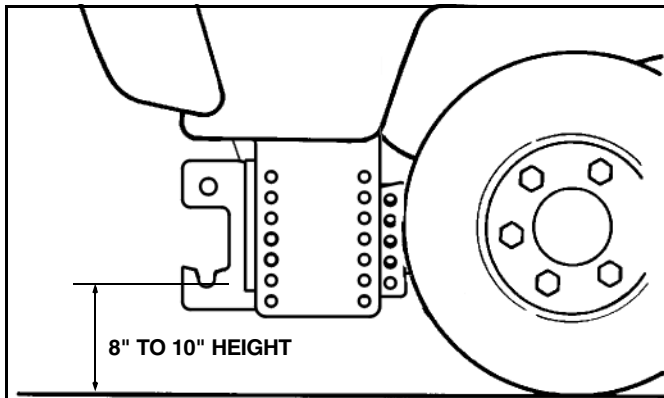

IMPORTANT: Height from the bottom of the lower pin slots on the Subframe to the ground should be between 8" and 10" to ensure proper operation.

PARTS LIST

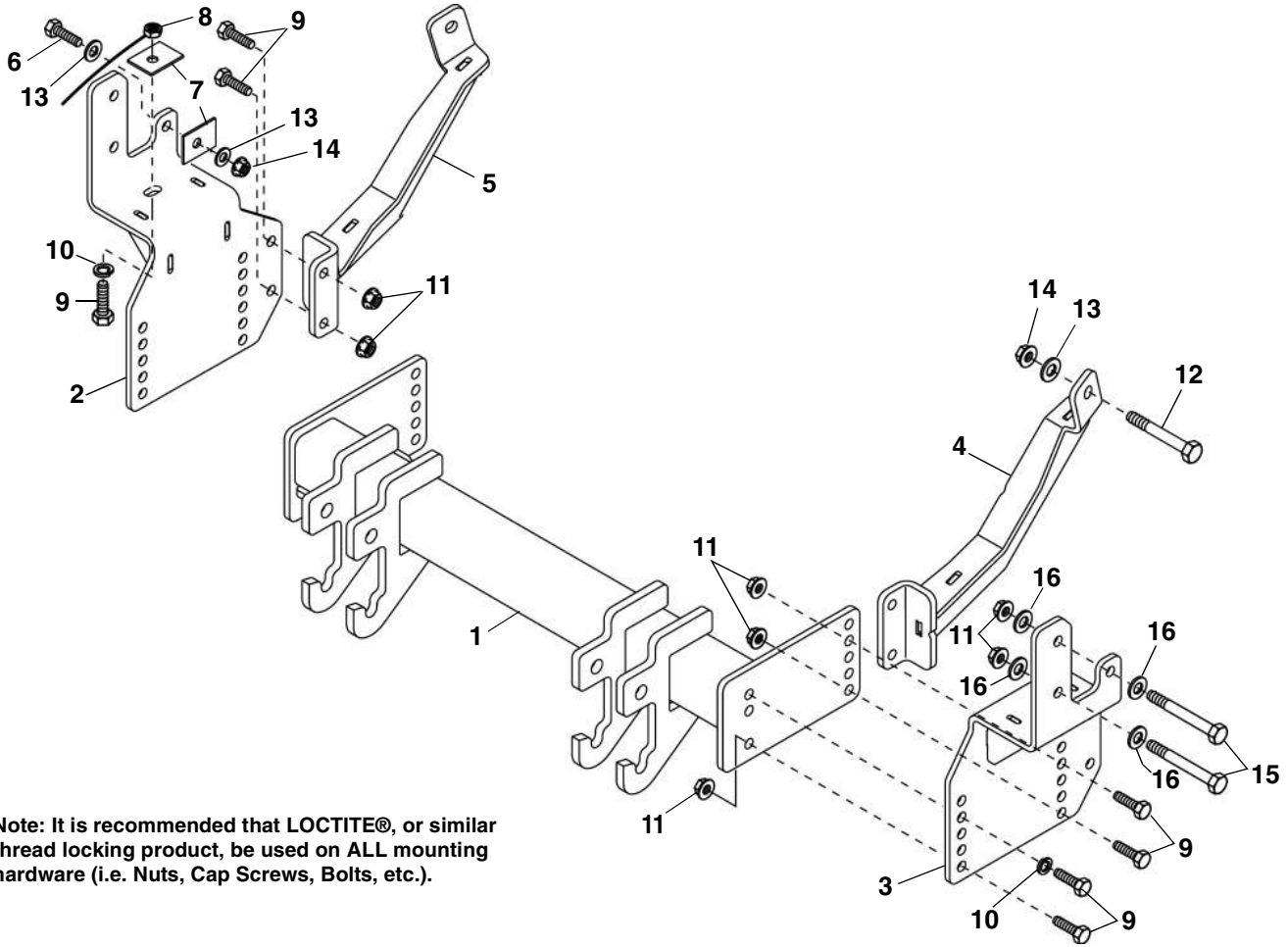

Note: It is recommended that LOCTITE®, or similar thread locking product, be used on ALL mounting hardware (i.e. Nuts, Cap Screws, Bolts, etc.).

ITEM	PART NO.	DESCRIPTION	QTY.
1	99100891	Vehicle Center Member.....	1
2		Front Mtg Weldment, PS.....	1
3		Front Mtg Weldment, DS.....	1
4		Rear Mtg Weldment, DS.....	1
5		Rear Mtg Weldment, PS.....	1
6		Hex Head Cap Screw, 5/8"-11 x 4-1/2".....	2
7		Shim Plate.....	4
8		Nut Wire Assembly.....	2
9		Hex Head Cap Screw, 1/2"-13 x 1-1/2".....	14
10		Lock Washer, 1/2".....	4
11		Nylock Nut, 1/2"-13.....	14
12		Hex Head Cap Screw, 5/8"-11 x 4".....	2
13		Flat Washer, 5/8".....	6
14		Nylock Nut, 5/8"-11.....	4
15		Hex Head Cap Screw, 1/2"-13 x 4-1/2".....	4
16		Flat Washer, 1/2".....	8
17	96113522	Kit, HDWE (Includes Items 6, 9-16) (Not Shown).....	1

SNO-WAY® INTERNATIONAL, INC.



Hartford, WI 53027 USA
 Website: www.snoway.com
 ©2012 Sno-Way® International