

# **SNO-WAY**®

**SNOW & ICE CONTROL EQUIPMENT**

## **ASSEMBLY & INSTALLATION INSTRUCTIONS**

**VEHICLE MOUNT KIT 99101079**

**TO FIT  
2011 & LATER FORD EXPLORER 4x4**

Sno-Way®, Down Pressure® and EIS® are registered trademarks of Sno-Way International, Inc.  
ProControl™, MegaBlade™, V-Wing™, E-Z Switch™, Revolution™, MaxAdjust™, SpeedLock™, and QuickJack™  
are trademarks of Sno-Way International, Inc.

©2011 Sno-Way® International

97101709A



1. **THINK SAFETY, ALWAYS WEAR SAFETY GLASSES WHEN PERFORMING THE OPERATIONS PRESCRIBED IN THESE INSTRUCTIONS**
2. **READ ALL INSTRUCTIONS CAREFULLY BEFORE ATTEMPTING INSTALLATION**
3. **BEFORE BEGINNING WORK MAKE SURE TO SET PARKING BRAKE AND CHOCK WHEELS**



### MINIMUM VEHICLE RECOMMENDATIONS

Heavy Duty Alternator  
Heavy Duty Battery

***NOTE:** On some vehicles it may be necessary to use a form of load booster to decrease the vehicle's front suspension sag with the snow plow in place. This can be accomplished with the use of supplementary air bags, booster springs, or similar load boosting devices. Since there are different load boosting devices available, it will up to the customer/end user to decide and purchase the product to suit the application, and not the responsibility of Sno-Way International, Inc.*

### ASSEMBLY TOOLS NEEDED

Drill Bits	1/4", 17/32"
Impact Sockets	7/16" – 1-3/8"
Metric Sockets	10 mm – 18 mm
Wrenches	7/16" – 1-3/8"
Metric Wrenches	10 mm – 18 mm
Torque Wrench	
Rat Tail Pry Bar	
Center Punch and Hammer	
**Rubber Bands**	

### INSTALLATION NOTES

1. **Unless otherwise specified, mount all Vehicle Mount Kit Components to vehicle before tightening any hardware.**
2. **It is recommended that LOCTITE®, or similar thread locking product, be used on ALL mounting hardware (i.e. Nuts, Cap Screws, Bolts, etc.).**
3. Vehicle should be parked on a level surface with a normal vehicle load on the FRONT suspension.
4. Items in parentheses ( ) refer to quantity required for this step. Items with a pound sign (#) indicate the part number as found in the parts list on the last page of this document.  
Example: (2) of item #8.
5. It may be necessary to relocate license plate holder. Check state and local laws for placement, if needed.

### MOUNTING INSTRUCTIONS

1. Remove the front bumper cover (fascia), splash guard and skid plate. Retain the skid plate and splash guard for re-installation if the Vehicle Mount Kit is removed.
2. Remove the lower air dam located just beneath the radiator and frame rails. See Figure 1.

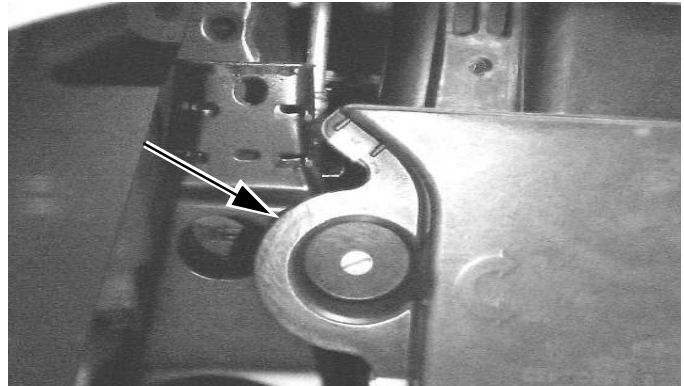

Figure 1

3. Draw a straight line, from front to back, between the two slots located under the front of the frame. Do this for both the Driver side and Passenger side. See Figure 2.

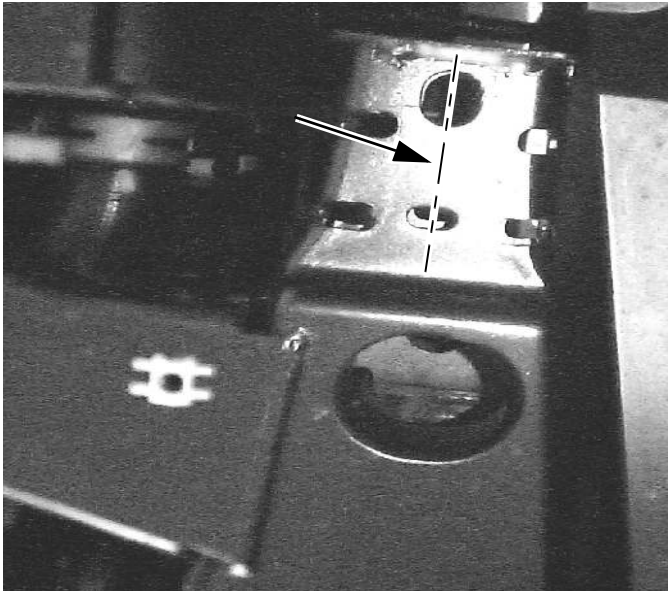

Figure 2

4. Place item #2 to the Driver Side vehicle frame rail: Mate the front and bottom plate of the weldment to the front and bottom surface of the frame rail.
5. Align the center of the hole in the bottom plate over the line that was drawn in step 3.
6. Draw a mark across the line to show the holes center. Also, mark where the center of the rear hole in the frame will be drilled.
7. While the weldment is still mated to the frame rail, mark where to grind/drill the front of the frame rail for the front 1/2" hole of the subframe.
8. Remove item #2 from the frame rail.
9. Using the center marks created in step 6, center punch, drill 1/4" pilot holes, then drill to 17/32". (DO NOT drill through both sides of the frame rails).
10. Grind/drill the front end of the frame rail enough for the 1/2" hole of the subframe.
11. Loosely attach item #2 to the Driver side frame rail using (1) of item #8, (2) of item #7, (1) of item #5.
12. Insert (1) of item #4 through (1) of item #6, item (#2), Truck Frame Rail, and into (1) of item #9.
13. Insert (1) of item #4 through (1) of item #6, (1) of item #7, item #2, Truck Frame Rail, and into (1) of item #9.
14. Repeat steps 4 through 13 to install item #3 on the passenger side.
15. Secure item #1 to items #2 & #3 using (8) of item #4 and (8) of item #5.

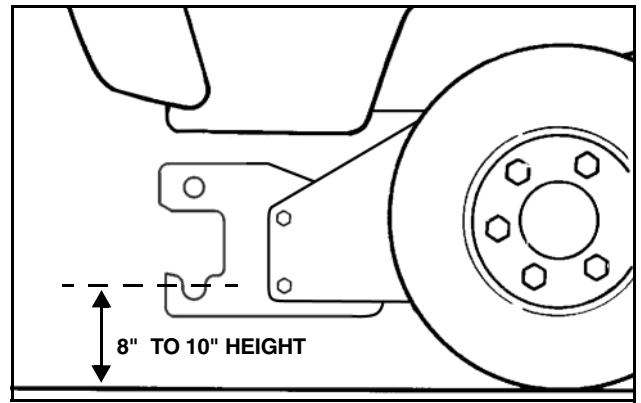

Figure 3

**NOTE: Height from the center of the lower Plow Mounting holes on the Vehicle Mount Kit to the ground should be between 8" and 10" to ensure proper operation.**

16. Using the Torque Specification Chart provided, torque all Cap Screws.

TORQUE SPECIFICATIONS FOR STANDARD MACHINE HARDWARE					
Bolt Size	GR.2 Dry	GR.5 Dry	GR.8 Dry	Metric Size	GR.8.8 Dry
1/4"	66*	9	12	M8	17
5/16"	11	17	25	M10	35
3/8"	20	30	45	M12	60
7/16"	32	50	70	M14	95
1/2"	50	75	110	M16	155
9/16"	70	110	150		
5/8"	100	150	220		
3/4"	175	260	380		
7/8"	170	430	600		
1"	250	640	900		

Note: These torque values are to be used for all hardware. Unless otherwise specified, all torque values must meet this specification.  
 Note: All torque values are in Ft.-Lbs unless otherwise stated  
 Note: \*In-Lbs

**REMEMBER After 5 to 10 hours of snowplow usage, re-torque all Cap Screws!**

17. Re-install front bumper cover (fascia).
18. Re-install the lower air dam, which was removed in step 2. Some modifications will need to be made to the lower air dam before being reassembled onto the vehicle.

# PARTS LIST

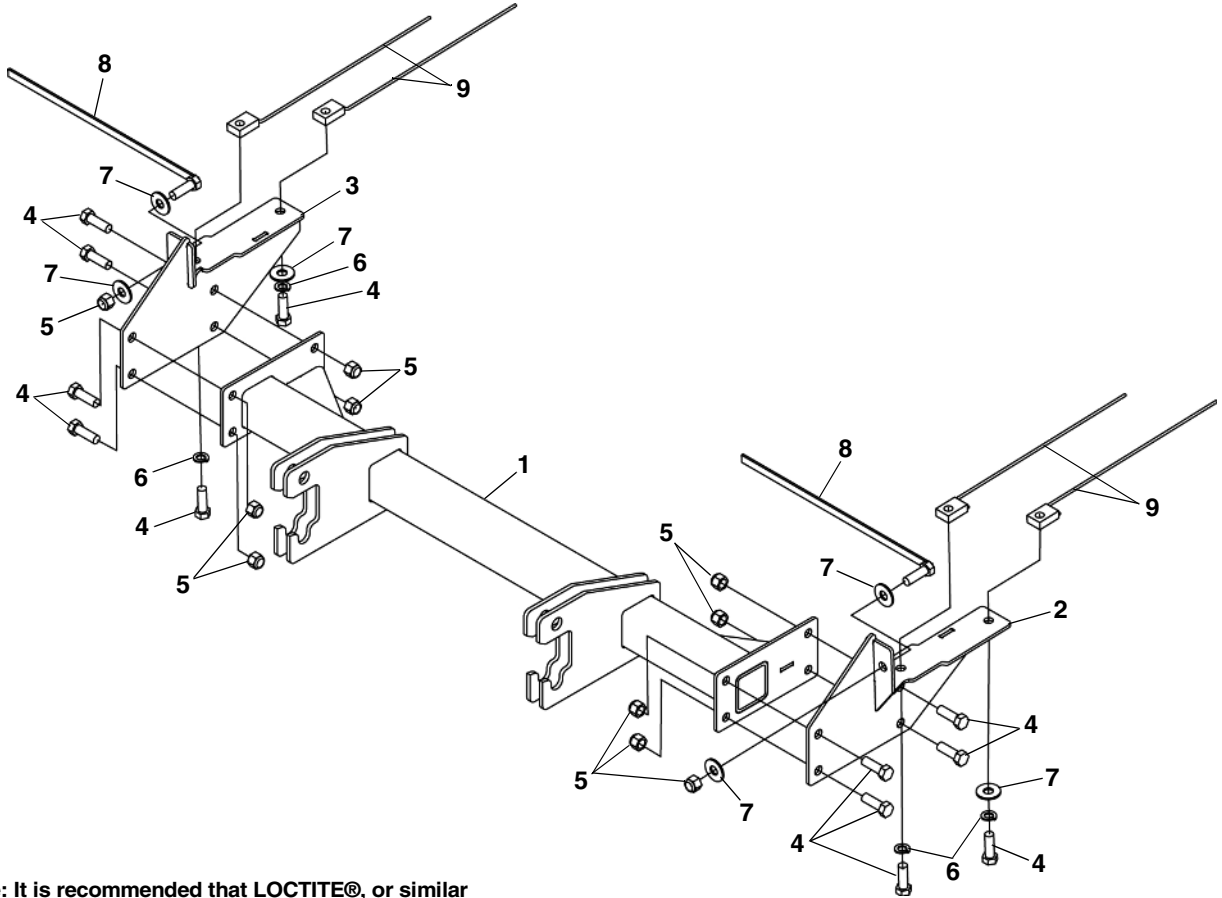

Note: It is recommended that LOCTITE®, or similar thread locking product, be used on ALL mounting hardware (i.e. Nuts, Cap Screws, Bolts, etc.).

ITEM	PART NO.	DESCRIPTION	QTY.
1	96114042*	Vehicle Center Mtg.....	1
2	96114046*	Mtg. Weldment, DS.....	1
3	96114052*	Mtg. Weldment, PS.....	1
4	98009010	Hex Head Cap Screw, 1/2"-13 x 1-1/2".....	12
5	98009013	Nylock Nut, 1/2"-13.....	10
6	98009012	Lock Washer, 1/2".....	4
7	98100176	Flat Washer, 1/2".....	6
8	96112384	Handle Bolt Weldment, HHCS, 1/2"-13 x 1-1/2" x 15".....	2
9	96107185	Nut Plate, Weldment.....	4

**NOTE:** \* Not Available as a Service Part.

SNO-WAY® INTERNATIONAL, INC.



Hartford, WI 53027 USA  
 Website: [www.snoway.com](http://www.snoway.com)  
 ©2011 Sno-Way® International