

SNO-WAY®

SNOW & ICE CONTROL EQUIPMENT

ASSEMBLY & INSTALLATION INSTRUCTIONS

**VEHICLE MOUNT KIT 99101106
AND
VEHICLE CENTER MEMBER 99100890**

TO FIT:
2007 - 2018 CHEVY 1500 SILVERADO 4X4
2019 CHEVY 1500 SILVERADO 4X4 (OLD BODY)
2007 - 2018 GMC 1500 SIERRA 4X4
2019 GMC 1500 SIERRA 4X4 (OLD BODY)
2007 - 2013 CHEVY 1500 AVALANCHE
2007 & LATER CHEVY TAHOE & SUBURBAN 4X4
2007 & LATER GMC YUKON 4X4
2007 & LATER CADILLAC ESCALADE 4X4

©2019 Sno-Way® International

97101775F



1. **THINK SAFETY, ALWAYS WEAR SAFETY GLASSES WHEN PERFORMING THE OPERATIONS PRESCRIBED IN THESE INSTRUCTIONS**
2. **READ ALL INSTRUCTIONS CAREFULLY BEFORE ATTEMPTING INSTALLATION**
3. **BEFORE BEGINNING WORK MAKE SURE TO SET PARKING BRAKE AND CHOCK WHEELS**



MINIMUM VEHICLE RECOMMENDATIONS

Heavy Duty Alternator
Heavy Duty Battery

NOTE: On some vehicles it may be necessary to use a form of load booster to decrease the vehicle's front suspension sag with the snow plow in place. This can be accomplished with the use of supplementary air bags, booster springs, or similar load boosting devices. Since there are different load boosting devices available, it will up to the customer/end user to decide and purchase the product to suit the application, and not the responsibility of Sno-Way International, Inc.

ASSEMBLY TOOLS NEEDED

Drill Bits	1/4", 17/32"
Impact Sockets	7/16" – 1-3/8"
Metric Sockets	10 mm – 18 mm
Wrenches	7/16" – 1-3/8"
Metric Wrenches	10 mm – 18 mm
Torque Wrench	
Cutting Wheel/Sawzall	
Center Punch and Hammer	
Touch Up Paint	
Rubber Bands	

INSTALLATION NOTES

1. Unless otherwise specified, mount all Vehicle Mount Kit Components to vehicle before tightening any hardware.
2. It is recommended that **LOCTITE®**, or similar thread locking product, be used on ALL mounting hardware (i.e. Nuts, Cap Screws, Bolts, etc.).
3. Vehicle should be parked on a level surface with a normal vehicle load on the FRONT suspension.
4. Items in parentheses () refer to quantity required for this step. Items in parentheses with a pound sign (#) indicate the part number as found in the parts list on the last page of this document.
Example: (2) 1/2"-13 x 1-1/2" Cap Screws (#8).
5. It may be necessary to relocate license plate holder. Check state and local laws for placement, if needed.

MOUNTING INSTRUCTIONS

NOTE: Sno-Way does NOT recommend Vehicles equipped with Adaptive Cruise Control and/or Crash Imminent Braking. Vehicles, if equipped, may need to turn the following packages or features OFF because of possible interference with the attached plow and/or spreader: Forward Collision Alert, Lane Departure Warning, Rear Cross Traffic Alert.

1. Remove bumper and retain hardware for reinstallation in a later step. Next, remove any tow hooks and retain with hardware, for use if vehicle mount kit is ever removed.

NOTE: If installing on a 2016 or later model that has a welded, threaded sleeve in the front of the frame rails, grind the lower half of the sleeve until it is flush with the vehicle frame (See Figure 1.). This will eliminate any interference with the mounting side brackets.

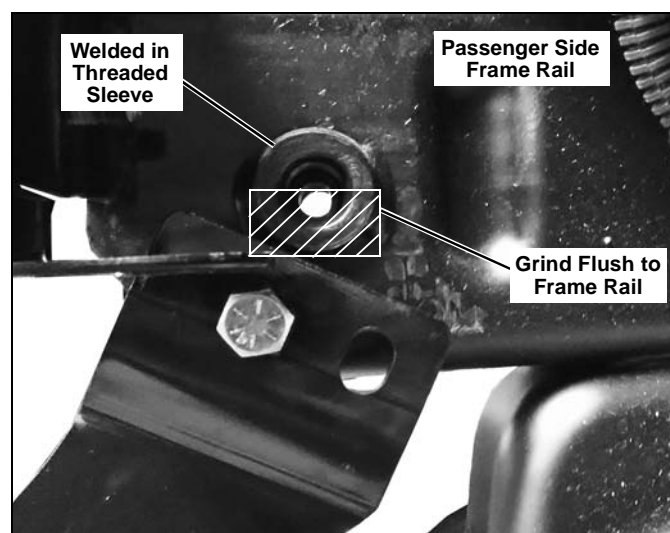

Figure 1

2. Install Side Bracket, PS (#3) (Passenger Side):
To the inside of the vehicle frame, align the front hole in the Side Bracket, PS (#3) with the existing tow hook hole in the frame:
 - Secure loosely using (1) 1/2"-13 x 1-1/2" Cap Screw (#5), (1) 1/2" Flat Washer (#8) and (1) 1/2"-13 Nylock Nut (#6).
 - Next, using the hole next to the front hole as a template, center punch and drill a 1/4" pilot hole, then drill to 17/32" through just the inside of the frame rail.
 - Next use the two rear holes in the Side Bracket, PS that butts up against the bottom and side of the frame rail as a template, center punch and drill a 1/4" pilot hole then drill to 17/32".
 - Secure loosely the hole next to the front hole using (1) 1/2"-13 x 1-1/2" Cap Screw (#9) (1) 1/2" Flat Washer (#8) and (1) 1/2"-13 Nylock Nut (#6).
The rear drilled holes should be secured using (2) Handle Bolt Assembly (#4) and (1) 1/2" Flat Washer (#8) inserted through the front of the frame rail.

NOTE: GREAT TIP: Use a rubber band to keep the washer from falling off when inserting into the frame.

3. Install Side Bracket, DS (#2) (Driver Side):

Installation is the same as step 2, but the two hook holes are both already in the inside of the frame rail on the DS side of the vehicle so you don't have to drill the hole into the side of the frame.

- Secure the rear side hole in the Side Bracket, DS (#2) using (1) 1/2"-13 x 1-1/2" Cap Screw (#5), (1) 1/2" Flat Washer (#8) and (1) 1/2"-13 Nylock Nut (#6).
Note: you still have to drill the one in the bottom and side of the frame rail.

4. Attach the Vehicle Center Member (#1) to the Side Brackets, DS (#2) and PS (#3). Secure using (8) 1/2"-13 x 1-1/2" Cap Screw (#5), (2) 1/2" Lock Washers (#7), and (6) 1/2"-13 Nylock Nut (#6).

5. With all the components now in place, tighten all the hardware. Using the Torque Specification Chart at the end of these instructions, torque all Cap Screws.

NOTE: The splash guard may need modifications if it is to be reinstalled with the vehicle mount kit attached.

6. Reinstall the bumper. The bumper may need to be cut (notched) to achieve the desired Vehicle Mount Kit height requirement.

- For 2014 and later 1500 pick-up models, continue.
- For 2015 and later Suburban, Tahoe and Yukon models, see page 3.

For 2014 and later 1500 pick-up models:

The following steps will assist in determining where to cut the bumper for re-installation.

7. On the inside of the bumper, there are some new bumper mounting brackets that require modification to fit 2014 & later pick-ups. Using a cutting wheel or Sawzall®, cut and remove the lower inside quadrant of the bumper mounting bracket as shown. Do this for the Driver Side and Passenger Side.

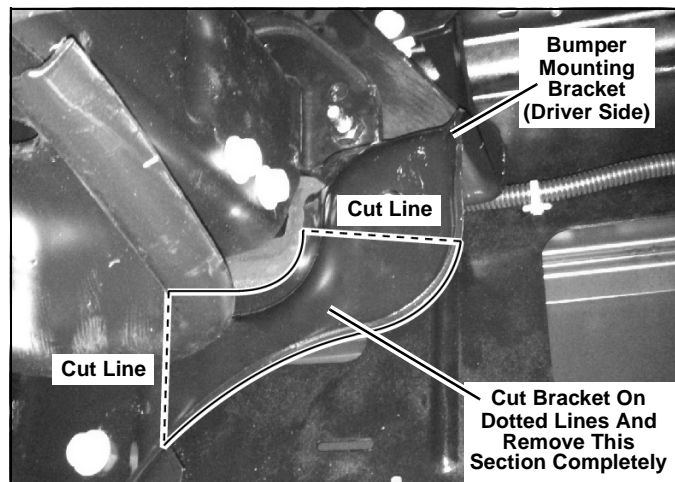

8. Locate and make marks on the front of the bumper at 9 in. and 14-1/2 in. from the center of the bumper on each side (See photo at bottom of this page).

9. The height at which the slot in the bumper must be cut will vary depending upon the vehicle suspension height and where in the 8-10 in. range the Vehicle Center Member is placed. A section that is a minimum of at least 3 in. up from the bottom edge will need to be cut out and removed.

10. Use touch up paint to dress any cut metal after completing these steps to minimize corrosion.

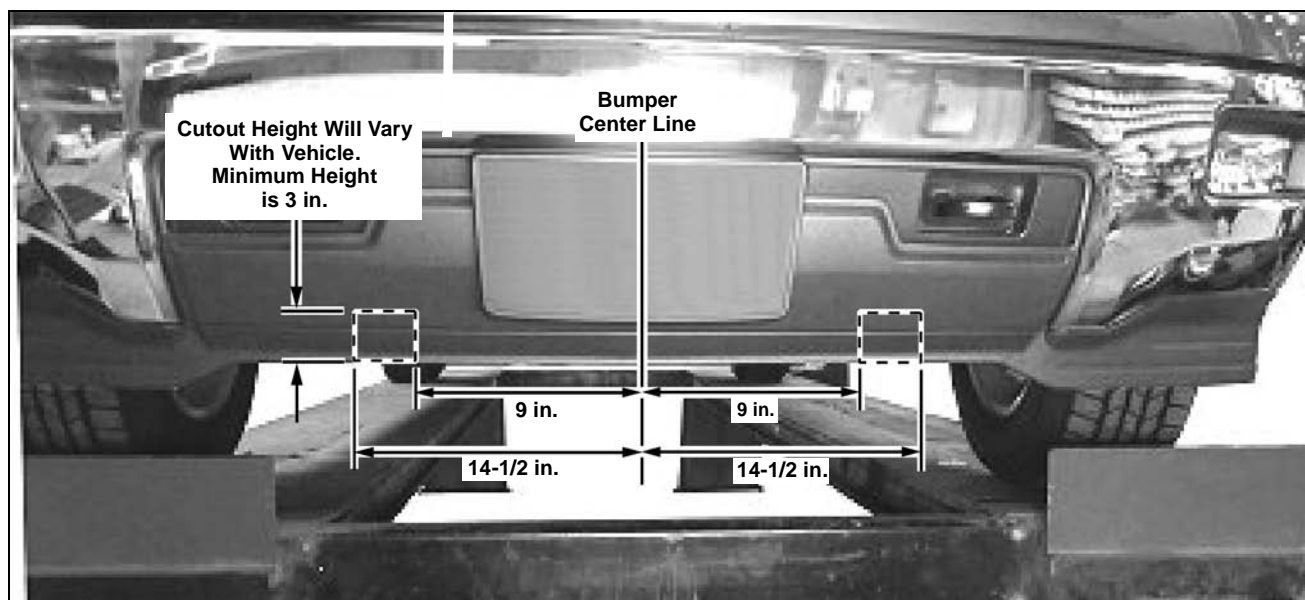

For 2015 and later Suburban, Tahoe and Yukon models:

The following steps will assist in determining where to cut the bumper for re-installation.

11. Locate and make marks on the front of the bumper at 9 in. and 14-1/2 in. from the center of the bumper on each side (See photo at bottom of this page).
12. The height at which the slot in the bumper must be cut will vary depending upon the vehicle suspension height and where in the 8-10 in. range the Vehicle Center Member is placed. A section that is a minimum of at least 3 in. up from the bottom edge will need to be cut out and removed.
13. Depending on the vehicle options, the vehicle may have a harness that runs directly behind the bumper. This harness may need to be relocated higher up on the bumper in order to mount the Vehicle Center Member, for reasons stated in step 12.

IMPORTANT: Height from the center of the lower Plow mounting holes on the Vehicle Mount Kit to the ground should be between 8" and 10" to insure proper operation.

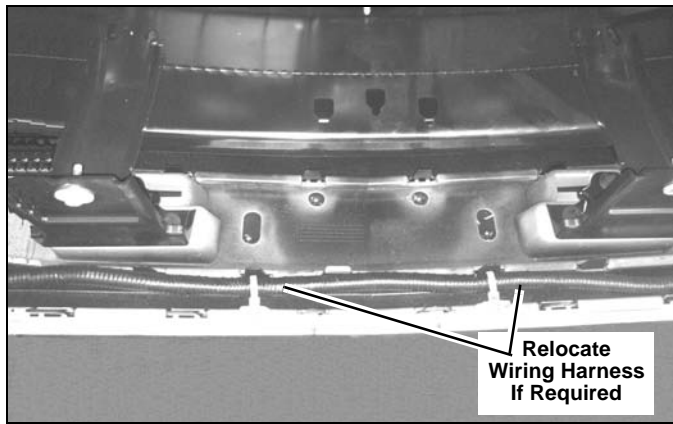
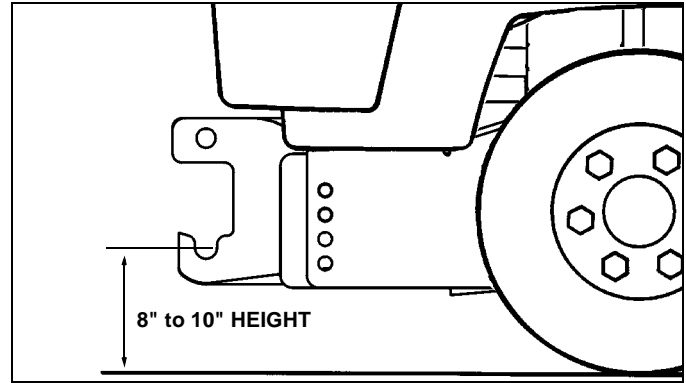

14. Use touch up paint to dress any cut metal after completing these steps to minimize corrosion.

TORQUE SPECIFICATIONS FOR STANDARD MACHINE HARDWARE

Bolt Size	GR.2 Dry	GR.5 Dry	GR.8 Dry	Metric Size	GR.8.8 Dry
1/4"	66*	9	12	M8	17
5/16"	11	17	25	M10	35
3/8"	20	30	45	M12	60
7/16"	32	50	70	M14	95
1/2"	50	75	110	M16	155
9/16"	70	110	150		
5/8"	100	150	220		
3/4"	175	260	380		
7/8"	170	430	600		
1"	250	640	900		

Note: These torque values are to be used for all hardware. Unless otherwise specified, all torque values must meet this specification.
Note: All torque values are in Ft.-Lbs unless otherwise stated
Note: *In-Lbs

REMEMBER After 5 to 10 hours of snowplow usage, re-torque all Cap Screws!

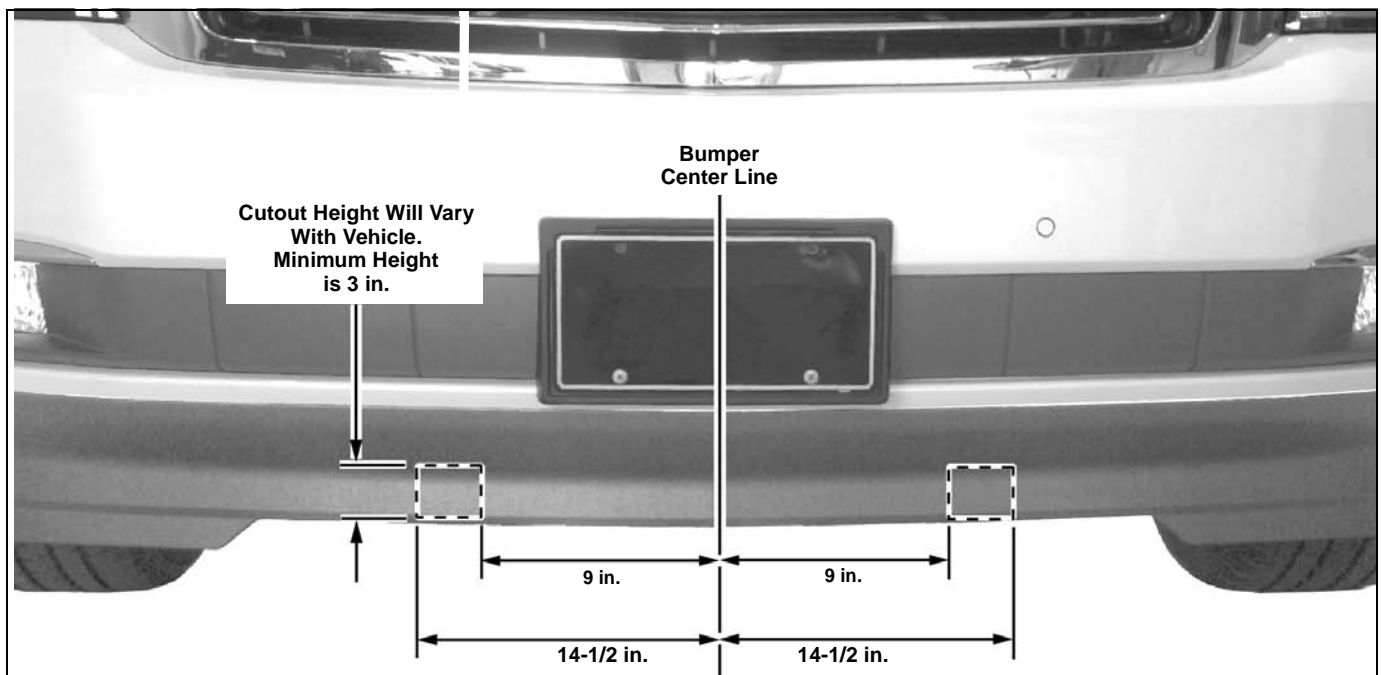

PARTS LIST

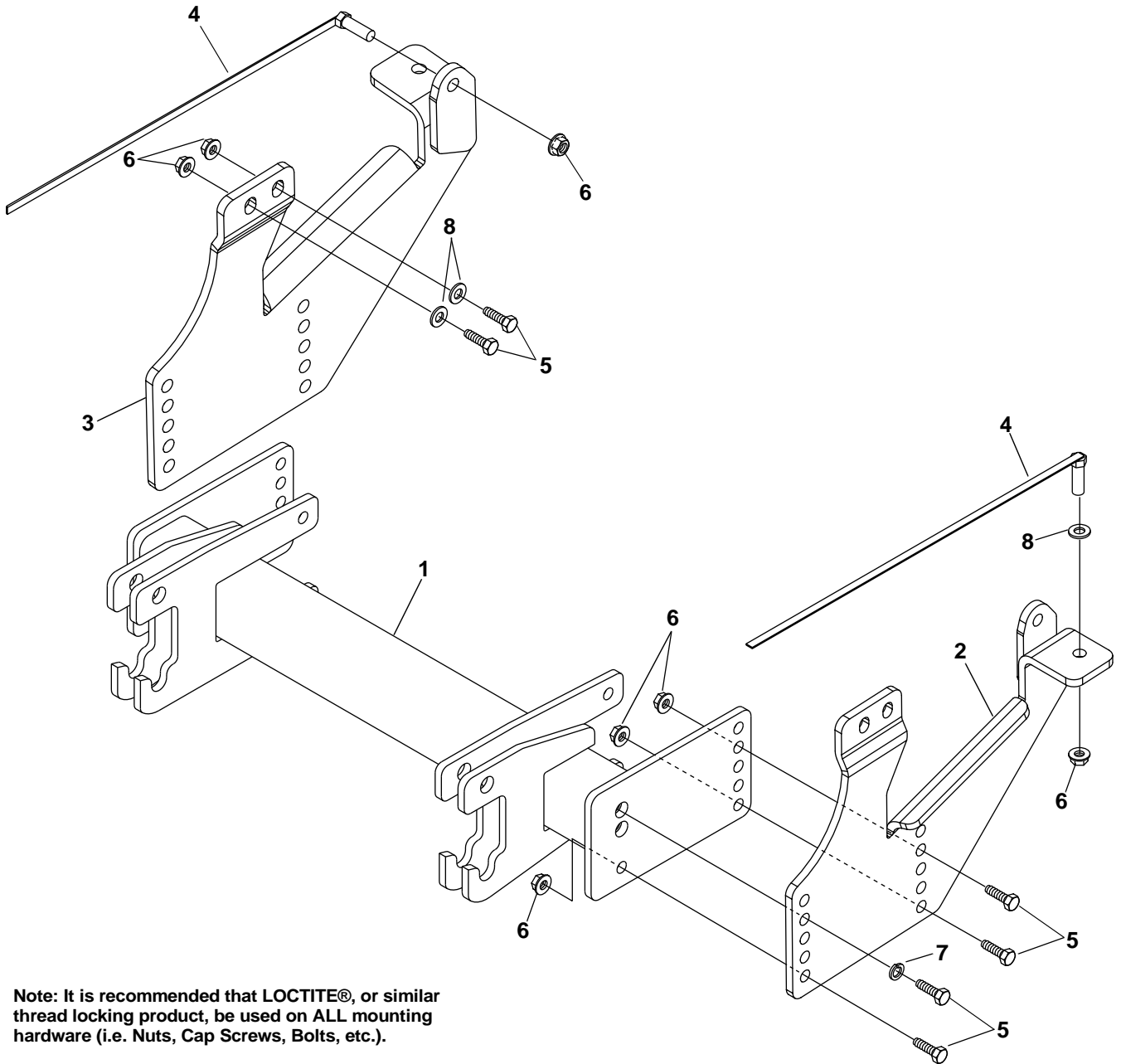

Note: It is recommended that LOCTITE®, or similar thread locking product, be used on ALL mounting hardware (i.e. Nuts, Cap Screws, Bolts, etc.).

ITEM	PART NO.	DESCRIPTION	QTY.
1	99100890	Vehicle Center Member	1
2		Bracket, Side, DS	1
3		Bracket, Side, PS	1
4		Handle Bolt Weldment	4
5		Cap Screw, Hex Head, 1/2"-13 x 1-1/2"	12
6		Nut, Nylock, 1/2"-13	14
7		Washer, Lock, 1/2"	2
8		Washer, Flat, A Wide	6
9	96114725	Kit, HDWE (Includes Items 4-8) (Not Shown)	1

NOTES

NOTES

SNO-WAY® INTERNATIONAL, INC.



Hartford, WI 53027 USA
Website: www.snoway.com
©2019 Sno-Way® International

www.storksplows.com