

SNO-WAY®

SNOW & ICE CONTROL EQUIPMENT

ASSEMBLY & INSTALLATION INSTRUCTIONS

**VEHICLE MOUNT KIT 99101127
USING
VEHICLE CENTER MEMBER 99100950**

TO FIT
1999-2004 FORD F250-F550 SUPER DUTY SERIES 4X4
2005-2007 FORD F250-F550 SUPER DUTY SERIES 4X4
NOTE: *An additional hardware kit (96114886) is required for 2005-2007 models*

Sno-Way®, Down Pressure® and EIS® are registered trademarks of Sno-Way International, Inc.
ProControl™, MegaBlade™, V-Wing™, E-Z Switch™, Revolution™, MaxAdjust™, SpeedLock™, and QuickJack™
are trademarks of Sno-Way International, Inc.

©2019 Sno-Way® International

97101808B



1. **THINK SAFETY, ALWAYS WEAR SAFETY GLASSES WHEN PERFORMING THE OPERATIONS PRESCRIBED IN THESE INSTRUCTIONS**
2. **READ ALL INSTRUCTIONS CAREFULLY BEFORE ATTEMPTING INSTALLATION**
3. **BEFORE BEGINNING WORK MAKE SURE TO SET PARKING BRAKE AND CHOCK WHEELS**



MINIMUM VEHICLE RECOMMENDATIONS

Heavy Duty Alternator
 Heavy Duty Battery
 Manufacturer's Snow Plow Package

NOTE: On some vehicles it may be necessary to use a form of load booster to decrease the vehicle's front suspension sag with the snow plow in place. This can be accomplished with the use of supplementary air bags, booster springs, or similar load boosting devices. Since there are different load boosting devices available, it will up to the customer/end user to decide and purchase the product to suit the application, and not the responsibility of Sno-Way International, Inc.

ASSEMBLY TOOLS NEEDED

Drill Bits	1/4", 17/32"
Impact Sockets	7/16" – 1-3/8"
Impact Sockets Metric	10mm – 19mm
Wrenches	7/16" – 1-3/8"
Wrenches Metric	10mm – 19mm
Torque Wrench	Rat Tail Pry Bar
Center Punch and Hammer	
Clamping Device ("C", Bar, type device...)	

INSTALLATION NOTES

1. **Unless otherwise specified, mount all Vehicle Mount Kit Components to vehicle before tightening any hardware.**
2. **It is recommended that LOCTITE®, or similar thread locking product, be used on ALL mounting hardware (i.e. Nuts, Cap Screws, Bolts, etc.).**
3. Vehicle should be parked on a level surface with a normal vehicle load on the FRONT suspension.
4. Items in parentheses () refer to quantity required for this step. Items in parentheses with a pound sign (#) indicate the part number as found in the parts lists in this document.
 Example: (4) 1/2" x 1-1/2" Cap Screws (#10).
5. It maybe necessary to relocate license plate holder. Check state and local laws for placement, if needed.

by removing the four (4) bolts that secure the bumper to the bumper support. Retain, with hardware, for replacement at end of installation.

*NOTE: It may be necessary to install spacers (provided between the bumper mounting plate and the Plates (#2 and #3) to ensure proper hole alignment between the Plates and Rear Weldments when hardware is secured. Test fit by loosely attaching a Plate, Bracket and Rear Weldment on one side of the vehicle (refer to Step 3, then Steps 6-8). **Do not install carriage bolts securing the Front Plate to the bumper mounting plate at this time.** Align the mounting holes in the Plate and Rear Weldment, then check for a gap between the Plate and bumper mounting plate. If a gap exists, add Spacers (#15 and/or #16) to fill the gap and maintain mounting hole alignment when all hardware is installed and tightened. Included in the hardware bag are (4) 1/2" x 2-1/2" Carriage Bolts to secure the Plates (#2 and #3) to the bumper mounting plate if Spacers are used.*

MOUNTING INSTRUCTIONS

1999-2004 Models (See Page 4 for 2005-2007 Models)

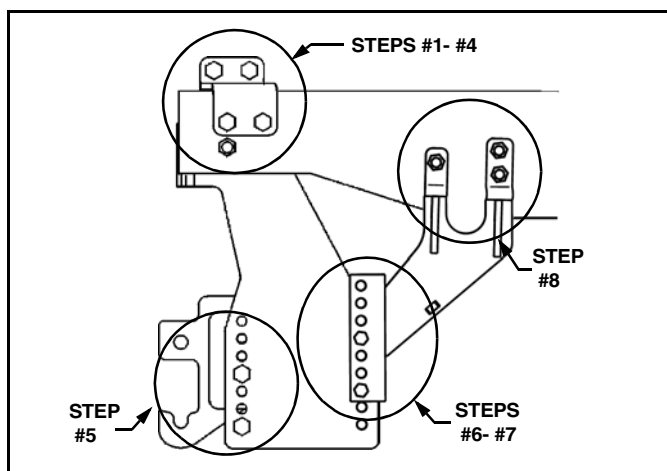

2. Install the Plates (#2, PS and #3, DS) to the inside of the frame, aligning with existing holes in the bumper mounting plate. Insert (4) 1/2" Carriage Bolts (#14, 1-1/2" long if not using spacers or 2-1/2" long with spacers) in the slots on the inward side of the tow hooks, and secure the Plates with (4) 1/2" Lock Washers (#12) and (4) 1/2" Hex Nuts (#17).
3. Position the Brackets (#4, PS and #5, DS) over the top of the truck frame and secure to the Plates (#2 and #3) with (4) 1/2" x 1-1/2" Cap Screws (#10) and (4) 1/2" Nylock Nuts (#9). Tighten the Nuts for proper alignment in the following steps.

1. Unsnap rubber portion of air dam and other items, if equipped, so that the front bumper can be removed completely. Remove vehicle front bumper assembly,



WARNING

Beware of brake and fuel lines secured to inside wall of frame rails when drilling holes in vehicle frame!

FAILURE TO HEED CAN RESULT IN INJURY OR DEATH!

4. Using the Plates and Brackets as a template, drill 1/4", then 17/32" holes through the sides of the frame rail in six places. Secure using (6) 1/2"-13 x 1-3/4" Cap Screws (#11) and (6) Nylock Nuts (#9).
5. Attach Vehicle Center Member (#1) to the Plates (#2 and #3) by aligning the front set of vertical holes in each member then using (4) 1/2"-13 x 1-3/4" Cap Screws (#11), (2) 1/2" Lock Washers (#12) in the threaded holes and (2) 1/2" Nylock Nuts (#9).
6. Align the Lower portion of the PS and DS Rear Weldments (#6 and #7) with the back vertical holes in the Plates (#2 and #3) and Vehicle Center Member (#1).
7. Loosely secure the Rear Weldments (#6 and #7) to the Plates (#2 and #3) and Vehicle Center Member (#1) using (4) 1/2"-13 x 2" Cap Screws (#18) and (4) Nylock Nuts (#9).
8. Loosely secure the Rear Weldments (#6 and #7) to the bottom of the truck frame rail using (4) 1/2" x 1-3/4" Cap Screws (#11), (8) 1/2" Flat Washers (#13) and (4) 1/2" Nylock Nuts (#9).

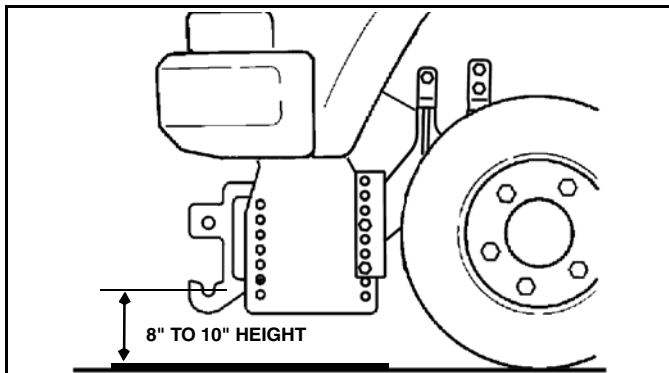

IMPORTANT: Height from the bottom of the lower pin slots on the Vehicle Mount Kit to the ground should be between 8" and 10" to insure proper operation. On some vehicles it may be necessary to use a form of load booster (See note page 1, Minimum Vehicle Recommendations).

9. Position the DS and PS Rear Weldments (#6 and #7) firmly against the side and bottom of the truck frame. **Note: the Rear Weldments may not lay flush against the bottom of the frame at this point. They may be interfering with the existing rivet in the frame. Be sure that the side of the Rear Brackets are flush against the side of the frame and continue the installation.** Using the holes on the side of the Rear Weldments as a template, drill 1/4" then 17/32" holes in the vehicle frame. Insert (6) 1/2" x 1-1/2" Handle Bolts (#8) through the openings in the front of the vehicle frame and align with the drilled holes. Secure using (6) Nylock Nuts (#12).
10. Using the Torque Specification chart provided, torque all bolts, starting at the rear and working forward.

TORQUE SPECIFICATIONS FOR STANDARD MACHINE HARDWARE

Bolt Size	GR.2 Dry	GR.5 Dry	GR.8 Dry	Metric Size	GR.8.8 Dry
1/4"	66*	9	12	M8	17
5/16"	11	17	25	M10	35
3/8"	20	30	45	M12	60
7/16"	32	50	70	M14	95
1/2"	50	75	110	M16	155
9/16"	70	110	150		
5/8"	100	150	220		
3/4"	175	260	380		
7/8"	170	430	600		
1"	250	640	900		

Note: These torque values are to be used for all hardware. Unless otherwise specified, all torque values must meet this specification.

Note: All torque values are in Ft.-Lbs unless otherwise stated

Note: *In-Lbs

11. Reinstall bumper and all other items previously removed. Position (4) 1/2" Flat washers (#13) on the existing bumper bolts between the bumper brackets and the bumper supports on the vehicle when replacing the front bumper.

REMEMBER After 5 to 10 hours of snowplow usage, re-torque all Cap Screws!

PARTS LIST

1999-2004 Models

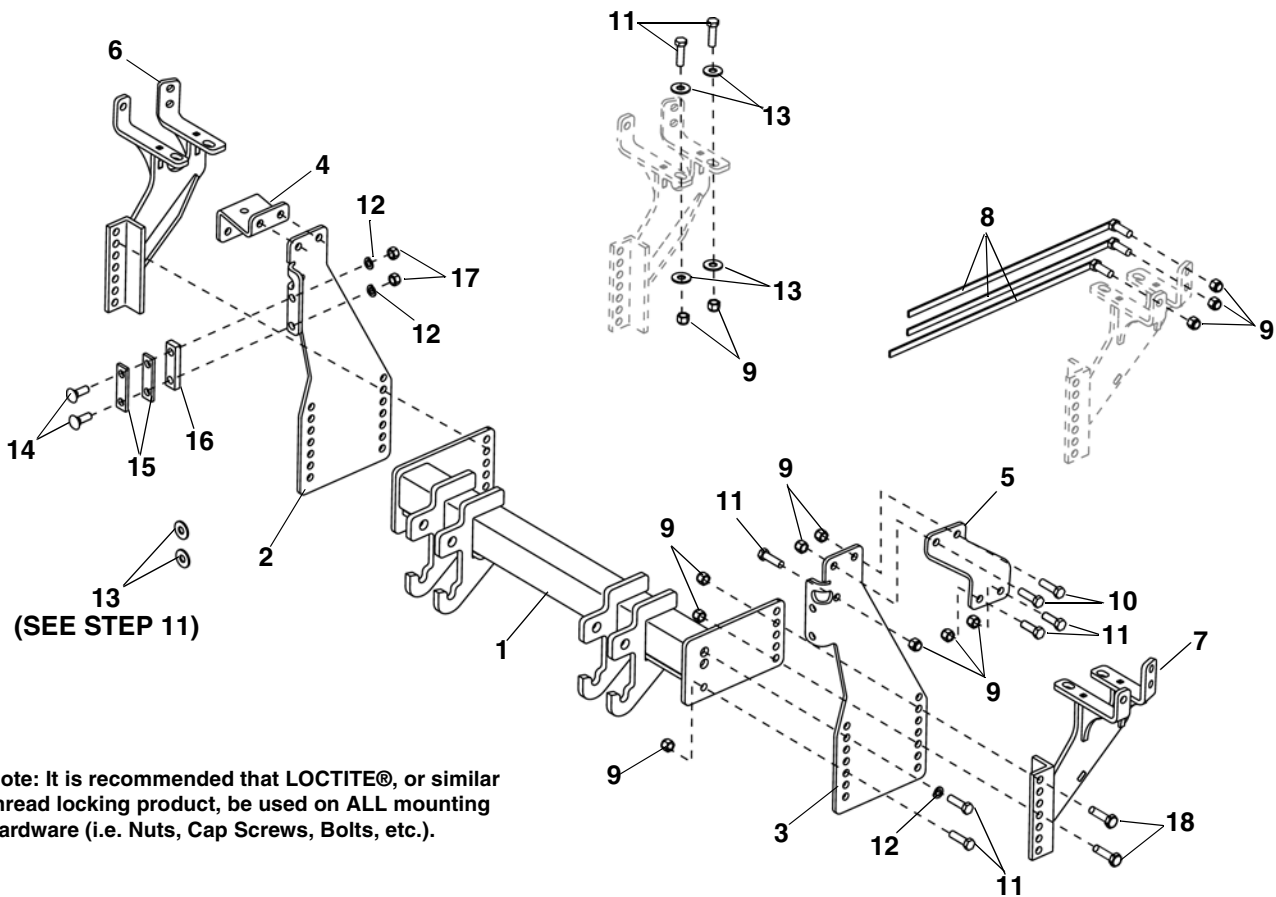

Note: It is recommended that LOCTITE®, or similar thread locking product, be used on ALL mounting hardware (i.e. Nuts, Cap Screws, Bolts, etc.).

ITEM	PART NO.	DESCRIPTION	QTY.
1	99100950	Vehicle Center Member	1
2		Plate, PS	1
3		Plate, DS	1
4		Bracket, PS.....	1
5		Bracket, DS	1
6		Rear Weldment, PS.....	1
7		Rear Weldment, DS	1
8		Handle Bolt, 1/2"-13 x 1-1/2"	6
9		LN, 1/2"-13	30
10		HHCS, 1/2"-13 x 1-1/2"	4
11		HHCS, 1/2"-13 x 1-3/4"	18
12		LW, 1/2"	6
13		PW, 1/2".....	12
14		CB, 1/2"-13 x 1-1/2".....	4
		CB, 1/2"-13 x 2-1/2".....	4
15		Spacer, 1/4"	4
16		Spacer, 1/2"	2
17		HN, 1/2"-13.....	4
18		HHCS, 1/2"-13 x 2".....	4
19	96114850	Kit, HDWE (Includes items 8-18) (Not Shown).....	1

INSTALLATION NOTES

1. Unless otherwise specified, mount all Vehicle Mount Kit Components to vehicle before tightening any hardware.
2. It is recommended that LOCTITE®, or similar thread locking product, be used on ALL mounting hardware (i.e. Nuts, Cap Screws, Bolts, etc.).
3. Vehicle should be parked on a level surface with a normal vehicle load on the FRONT suspension.
4. Items in parentheses () refer to quantity required for this step. Items in parentheses with a pound sign (#) indicate the part number as found in the parts lists in this document.
Example: (4) 1/2" x 1-1/2" Cap Screws (#10).
5. It maybe necessary to relocate license plate holder. Check state and local laws for placement, if needed.

MOUNTING INSTRUCTIONS

2005-2007 Models (See Page 1 for 1999-2004 Models)

NOTE: Hardware Kit 96114886 is required for installation on 2005-2007 models.

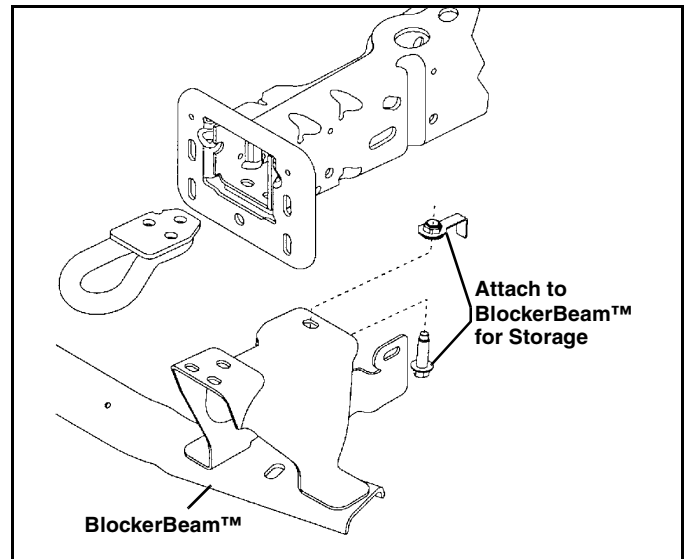

NOTE: It may be necessary to install Spacers (provided) between the bumper mounting plate and the Front Plates (#2 and #3) to ensure proper hole alignment between the Front Plates and Rear Weldments when hardware is secured.

Test fit by loosely attaching a Front Plate, Front Bracket and Rear Weldment on one side of the vehicle (refer to Step 3 & 4, then Steps 6, 8-9). Do not install Carriage Bolts securing the Front Plate to the bumper mounting plate at this time.

Align the mounting holes in the Front Plate and Rear Weldment, then check for a gap between the Front Plate and bumper mounting plate. If a gap exists, add Spacers (#15 and/or #26) to fill the gap and maintain mounting hole alignment when all hardware is installed and tightened. Included in the hardware bag are (4) 1/2" x 2-1/2" Carriage Bolts to secure the Front Plates (#2 and #3) to the bumper mounting plate if Spacers are used.



WARNING

According to the Ford Owner Guide, removing the BlockerBeam™ without installing snow plow attachment hardware may affect air bag deployment in a crash. **DO NOT** operate the truck unless either the BlockerBeam™ or snow plow attachment hardware is installed on the vehicle!

FAILURE TO FOLLOW CAN RESULT IN INJURY OR DEATH.

1. This vehicle is equipped with a new detachable BlockerBeam™. It is attached to the frame horns, behind the bumper. Disconnect the rubber air deflector from the BlockerBeam™, then unbolt and remove the BlockerBeam™ and tow hooks from the truck frame. Retain, with hardware, for future use if Vehicle Mount Kit is removed. **BlockerBeam™ must be reinstalled if the Vehicle Mount Kit is ever removed, and must be transferred when vehicle is sold or traded.**
2. Remove the bumper by first removing any electrical cords attached to bumper (diesel engine and vehicles with fog lamps). Remove the bumper fasteners and save with BlockerBeam™.

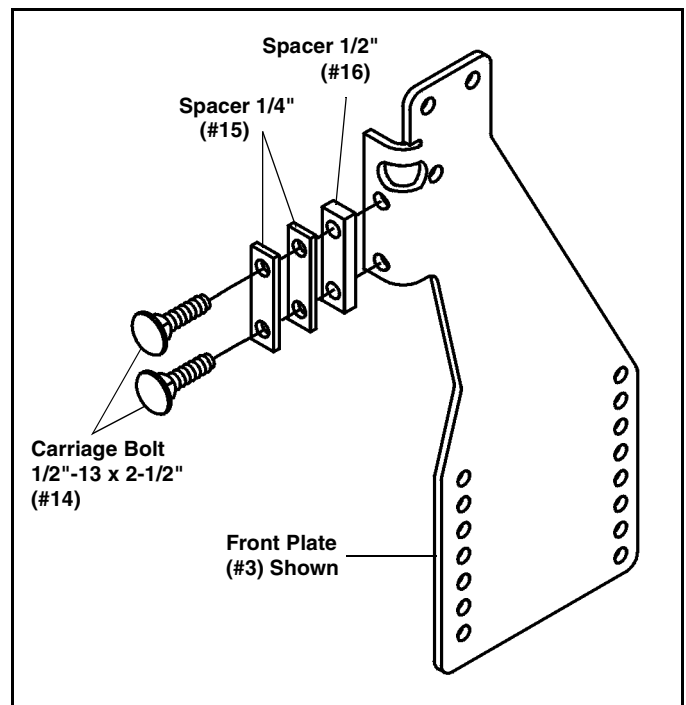

3. Install the Front Plates (#2, PS and #3, DS) at the inside of the frame, aligning with existing holes in the bumper mounting plate. Insert (4) 1/2" Carriage Bolts (#14, 1-1/2" long if not using spacers or 2-1/2" long with spacers) in the slots on the inward side of the tow hooks and secure the Front Plates with (4) 1/2" Lock Washers (#12) and (4) 1/2" Hex Nuts (#19).
4. Position the Front Brackets, (#5, DS and #4, PS) over the top of the truck frame and secure to the Front Plates (#2 and #3) with (4) 1/2" x 1-1/2" Cap Screws (#10) and (4) 1/2" Nylock Nuts (#9). Tighten the Nylock Nuts for proper alignment in the following steps.



WARNING

Beware of brake and fuel lines secured to inside wall of frame rails when drilling holes in vehicle frame!

FAILURE TO FOLLOW CAN RESULT IN INJURY OR DEATH.

5. Using the Front Plates and Brackets as a template, drill 1/4", then 17/32" holes through the sides of the truck frame in six places. Secure using (6) 1/2" x 1-3/4" Cap Screws (#11) and (6) 1/2" Nylock Nuts (#9).
6. Remove the four sway bar bracket bolts and remove the retained nut plates from the sway bar bracket. Allow the sway bar bushings and U-bracket to separate from the vehicle frame.
7. Remove the U-brackets for the sway bar. Drill the two holes in each U-bracket to 17/32" to allow clearance for 1/2" bolts. Save for installation in step 9.

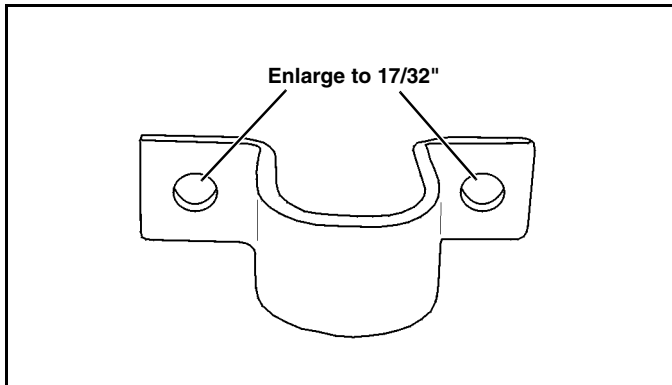

8. Attach Vehicle Center Member (#1) to the Plates (#2 and #3) by aligning the front set of vertical holes in each member then using (4) 1/2"-13 x 1-3/4" Cap Screws (#11), (2) 1/2" Lock Washers (#12) in the threaded holes and (2) 1/2" Nylock Nuts (#9).

9. Insert the Rear Weldments (#7, DS and #6, PS) between the bottom of the truck frame and the U-brackets, just drilled. To take up the gap between the sway bar bushing and the frame, insert (2) Rubber Spacers (#18). Loosely attach the Rear Weldments using (4) 1/2" x 1-3/4" Cap Screws (#11), (8) 1/2" Flat Washers (#13) (2 on top of the sway bar bracket and 2 on the bottom of the modified U-bracket per side) and (4) 1/2" Nylock Nuts (#9).

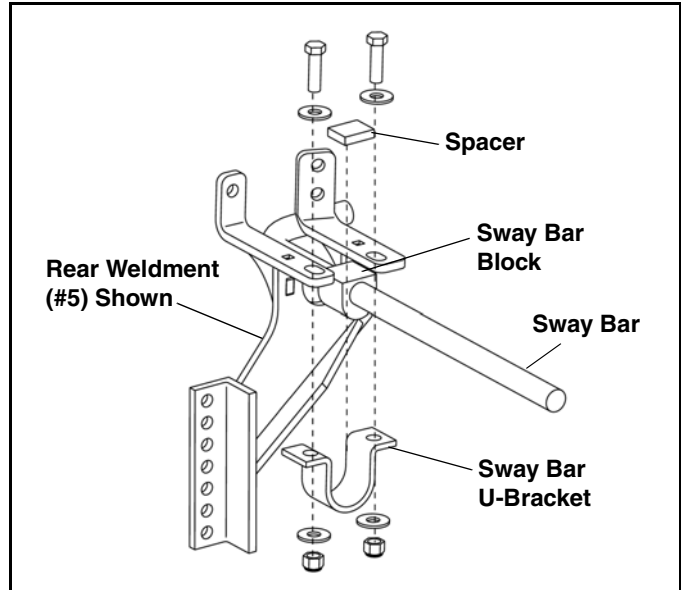

10. Align the Lower portion of the PS and DS Rear Weldments (#6 and #7) with the back vertical holes in the Plates (#2 and #3) and Vehicle Center Member (#1).
11. Loosely secure the Rear Weldments (#6 and #7) to the Plates (#2 and #3) and Vehicle Center Member (#1) using (4) 1/2"-13 x 1-3/4" Cap Screws (#11) and (4) Nylock Nuts (#9).

IMPORTANT: Height from the bottom of the lower pin slots on the Vehicle Mount Kit to the ground should be between 8" and 10" to insure proper operation. On some vehicles it may be necessary to use a form of load booster (See note page 1, Minimum Vehicle Recommendations).

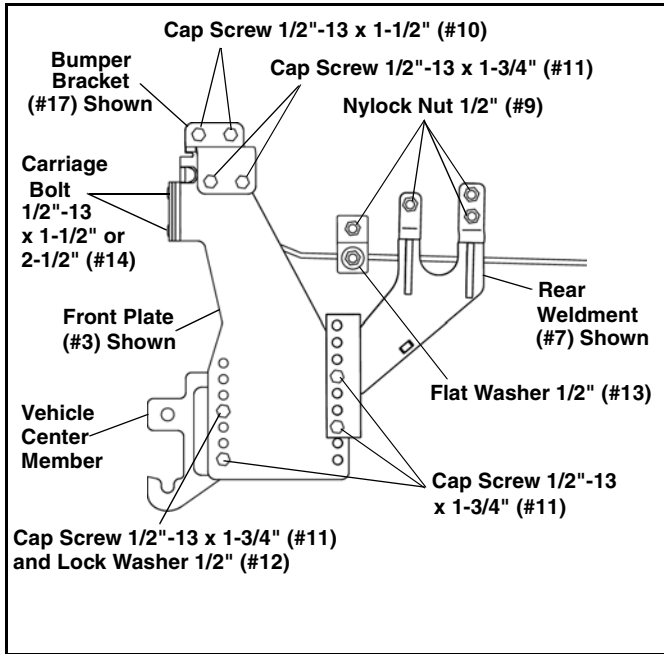

15. Reinstall bumper and all other items previously removed. Position (4) 1/2" Flat washers (#13) on the existing bumper bolts between the bumper brackets and the bumper supports on the vehicle when re-installing the front bumper.
16. Re-attach the side bumper brackets(#17) using (1) 1/2" X 1-1/2" Cap Screw (#10), (2) 1/2" Flat Washers (#13), and (1) 1/2" Nylock Nut (#9) on each side.

REMEMBER After 5 to 10 hours of snowplow usage, re-torque all Cap Screws!

12. Position the DS and PS Rear Weldments (#6 and #7) firmly against the side and bottom of the truck frame. Using the holes on the side of the Rear Weldments as a template, drill 1/4" then 17/32" holes in the vehicle frame. Insert (6) Handle Bolt (#8) through the opening in the front of the vehicle frame and align with the drilled holes. Secure using (6) Nylock Nuts (#9).
13. Insert (1) Handle Bolt (#8) through the front of each frame rail and through the existing hole between the front and rear weldments, on the outside. Align (1) Bumper Bracket (#17) over the Handle Bolt (#8) on each side. Then, secure with (2) 1/2" Nylock Nuts (#9)
14. Using the Torque Specification Chart below, torque all bolts, **starting at the rear** and working forward.

TORQUE SPECIFICATIONS FOR STANDARD MACHINE HARDWARE					
Bolt Size	GR.2 Dry	GR.5 Dry	GR.8 Dry	Metric Size	GR.8.8 Dry
1/4"	66*	9	12	M8	17
5/16"	11	17	25	M10	35
3/8"	20	30	45	M12	60
7/16"	32	50	70	M14	95
1/2"	50	75	110	M16	155
9/16"	70	110	150		
5/8"	100	150	220		
3/4"	175	260	380		
7/8"	170	430	600		
1"	250	640	900		

Note: These torque values are to be used for all hardware. Unless otherwise specified, all torque values must meet this specification.
 Note: All torque values are in Ft.-Lbs unless otherwise stated
 Note: *In-Lbs

PARTS LIST

2005-2007 Models

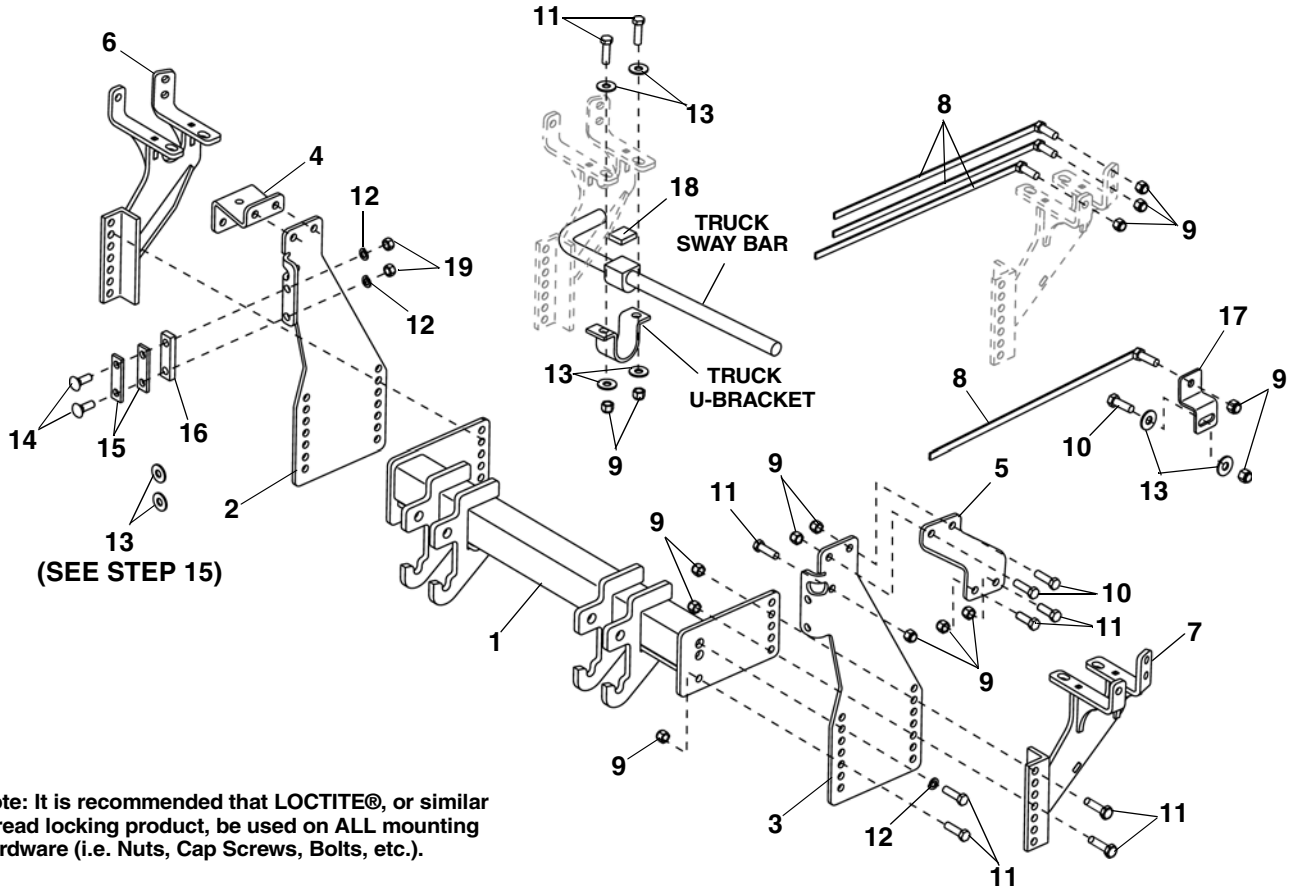

Note: It is recommended that LOCTITE®, or similar thread locking product, be used on ALL mounting hardware (i.e. Nuts, Cap Screws, Bolts, etc.).

ITEM	PART NO.	DESCRIPTION	QTY.
1	99100950	Vehicle Center Member	1
2		Plate, PS.....	1
3		Plate, DS	1
4		Bracket, PS.....	1
5		Bracket, DS.....	1
6		Rear Weldment, PS.....	1
7		Rear Weldment, DS.....	1
8		Handle Bolt, 1/2"-13 x 1-1/2"	8
9		LN, 1/2"-13	30
10		HHCS, 1/2"-13 x 1-1/2"	6
11		HHCS, 1/2"-13 x 1-3/4"	18
12		LW, 1/2"	6
13		PW, 1/2".....	16
14		CB, 1/2"-13 x 1-1/2"	4
		CB, 1/2"-13 x 2-1/2"	4
15		Spacer, 1/4"	4
16		Spacer, 1/2"	2
17		Bumper Bracket.....	1
18		Rubber Spacer	2
19		HN, 1/2"-13.....	4
20	96114850	Kit, HDWE (Includes items 8-16) (Not Shown).....	1
21	96114886	Kit, HDWE (Includes items 8-10, 13, 17, 18) (Not Shown).1	1

SNO-WAY® INTERNATIONAL, INC.



Hartford, WI 53027 USA
 Website: www.snoway.com
 ©2019 Sno-Way® International