

SNO-WAY®

SNOW & ICE CONTROL EQUIPMENT

ASSEMBLY & INSTALLATION INSTRUCTIONS

**VEHICLE MOUNT KIT 99101130
FOR UTV SERIES PLOW**

TO FIT
2013 & Later - Polaris 900



©2013 Sno-Way® International

97101819A



1. THINK SAFETY, ALWAYS WEAR SAFETY GLASSES WHEN PERFORMING THE OPERATIONS PRESCRIBED IN THESE INSTRUCTIONS
2. READ ALL INSTRUCTIONS CAREFULLY BEFORE ATTEMPTING INSTALLATION
3. BEFORE BEGINNING WORK MAKE SURE TO SET PARKING BRAKE AND CHOCK WHEELS



ASSEMBLY TOOLS NEEDED

Drill Bits	1/4" - 17/32"
Impact Sockets	7/16" - 1-3/8"
Wrenches	7/16" - 1-3/8"
Torque Wrench	
Rat Tail Pry Bar	
Center Punch and Hammer	
C-Clamp	
Screwdrivers	

INSTALLATION NOTES

1. Vehicle should be parked on a level surface with a normal vehicle load on the FRONT suspension.
2. On some vehicles it may be necessary to raise or stiffen the suspension to decrease the vehicles front suspension sag with the snow plow in place.
3. Unless otherwise specified, mount all Vehicle Mount Kit Components to vehicle before tightening any hardware.
4. It is recommended that LOCTITE®, or similar thread locking product, be used on ALL mounting hardware (i.e. Nuts, Cap Screws, Bolts, etc.).
5. Items in parentheses () refer to quantity required for this step. Items in parentheses with a pound sign (#) indicate the part number as found in the parts list on the last page of this document.
Example: (2) 1/2" Lock Washers (#9).

MOUNTING INSTRUCTIONS

1. Remove the Bumper/Brush Guard by removing two bolts under the Ranger and two bolts behind the Bumper/Brush Guard located near the top.
2. Behind the Bumper/Brush Guard are four square holes in the frame. Align these holes with the four holes in the top bracket. Install (4) 3/8" x 1-1/4" carriage bolts (#6) thru the square holes in the frame and into the top bracket (#5). Loosely secure with (4) 3/8" flat washers (#9) and (4) 3/8" lock nuts (#10). Do not tighten.

4. Place the bottom bracket (#2) under the UTV and align the 4 holes in the bracket with the holes in the frame. The front 2 align with the holes for the Bumper/Brush Guard and the back two align with open holes in the frame. Insert the bottom Bumper /Brush Guard bolts and nuts in the front holes and (2) 3/8" x 1" bolts (#7) and (2) 3/8" lock nuts (#10) in back. Do not tighten.

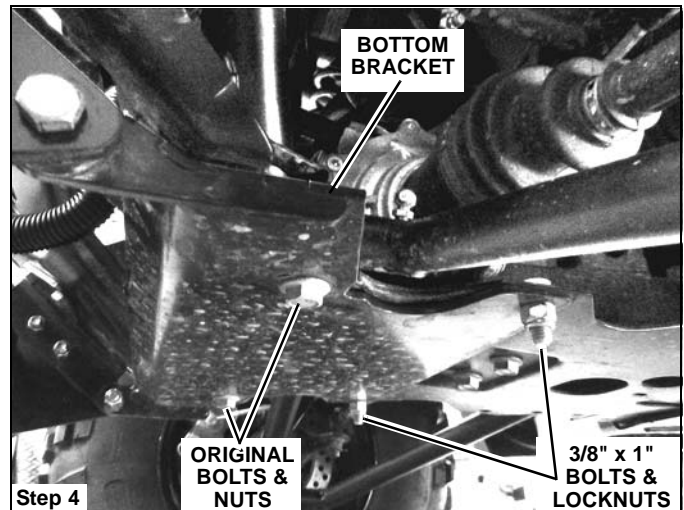
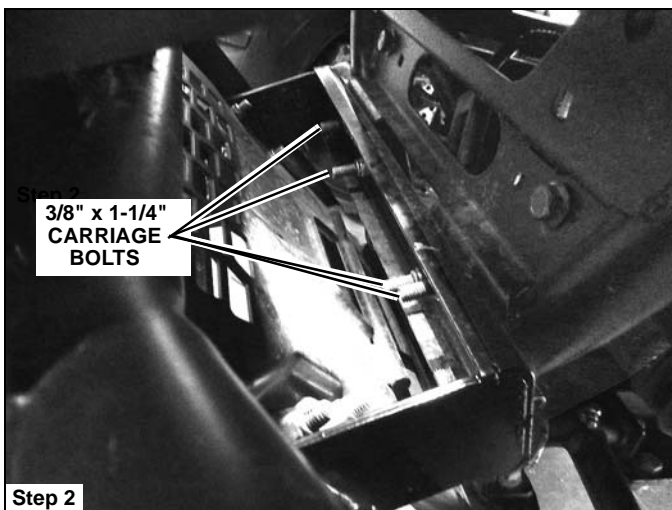

3. Replace Bumper/Brush Guard and insert top bolts only. Leave hand tight.

5. Align the DS Front Bracket (#3) slots with the holes in the bumper /brush guard and top bracket (#5). Loosely secure with (2) 3/8" x 1-1/4" bolts (#8), (2) 3/8" flat washers (#9) and (2) 3/8" lock nuts (#10). Do not tighten.

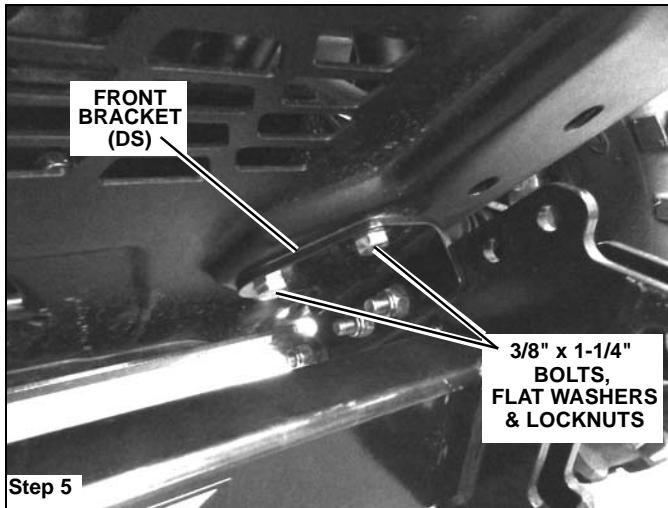

8. Loosely secure UTV Mount with (6) 3/8" x 1-1/4" bolts (#8) and (6) 3/8" lock nuts (#10).

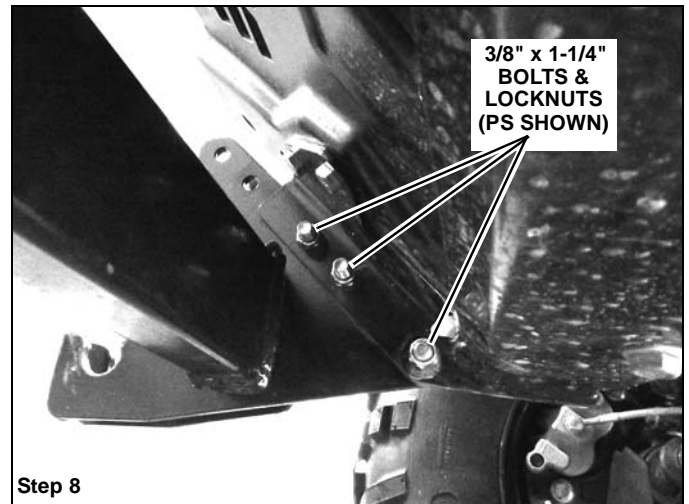

6. Repeat step 5 for passenger side front bracket (#4).
 7. Align the UTV Mount (#1) with the holes in the front brackets (#3 & 4). Adjust the UTV Mount (#1) so that the center of the bottom slot is 11-12 inches off of the ground.

NOTE: The bottom bolt on each side will go thru the bottom bracket, front bracket, and UTV Mount.

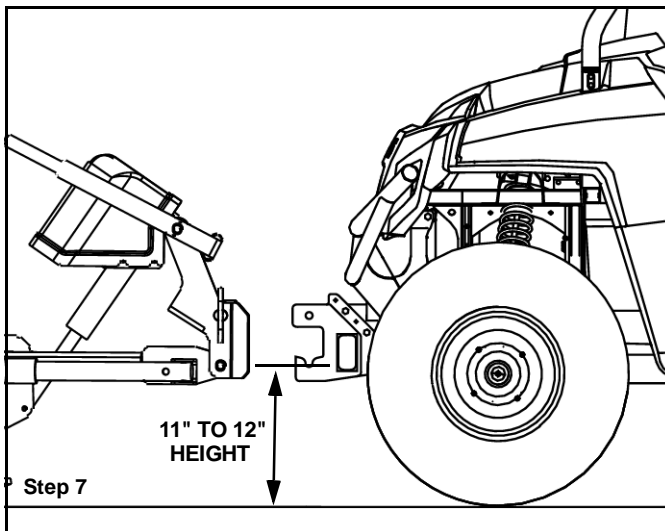

IMPORTANT: Height from the bottom of the lower pin slots on the UTV Mount to the ground should be between 11" and 12" to ensure proper operation.

9. Tighten all hardware using the Torque Specification Chart below.

TORQUE SPECIFICATIONS FOR STANDARD MACHINE HARDWARE					
Bolt Size	GR.2 Dry	GR.5 Dry	GR.8 Dry	Metric Size	GR.8.8 Dry
1/4"	66*	9	12	M8	17
5/16"	11	17	25	M10	35
3/8"	20	30	45	M12	60
7/16"	32	50	70	M14	95
1/2"	50	75	110	M16	155
9/16"	70	110	150		
5/8"	100	150	220		
3/4"	175	260	380		
7/8"	170	430	600		
1"	250	640	900		

These torque values are to be used for all hardware. Unless otherwise specified, all torque values must meet this specification.
 All torque values are in Ft.-Lbs unless otherwise stated
 *In-Lbs

REMEMBER After 5 to 10 hours of snowplow usage, re-torque all hardware!

PARTS LIST

Note: It is recommended that LOCTITE®, or similar thread locking product, be used on ALL mounting hardware (i.e. Nuts, Cap Screws, Bolts, etc.).

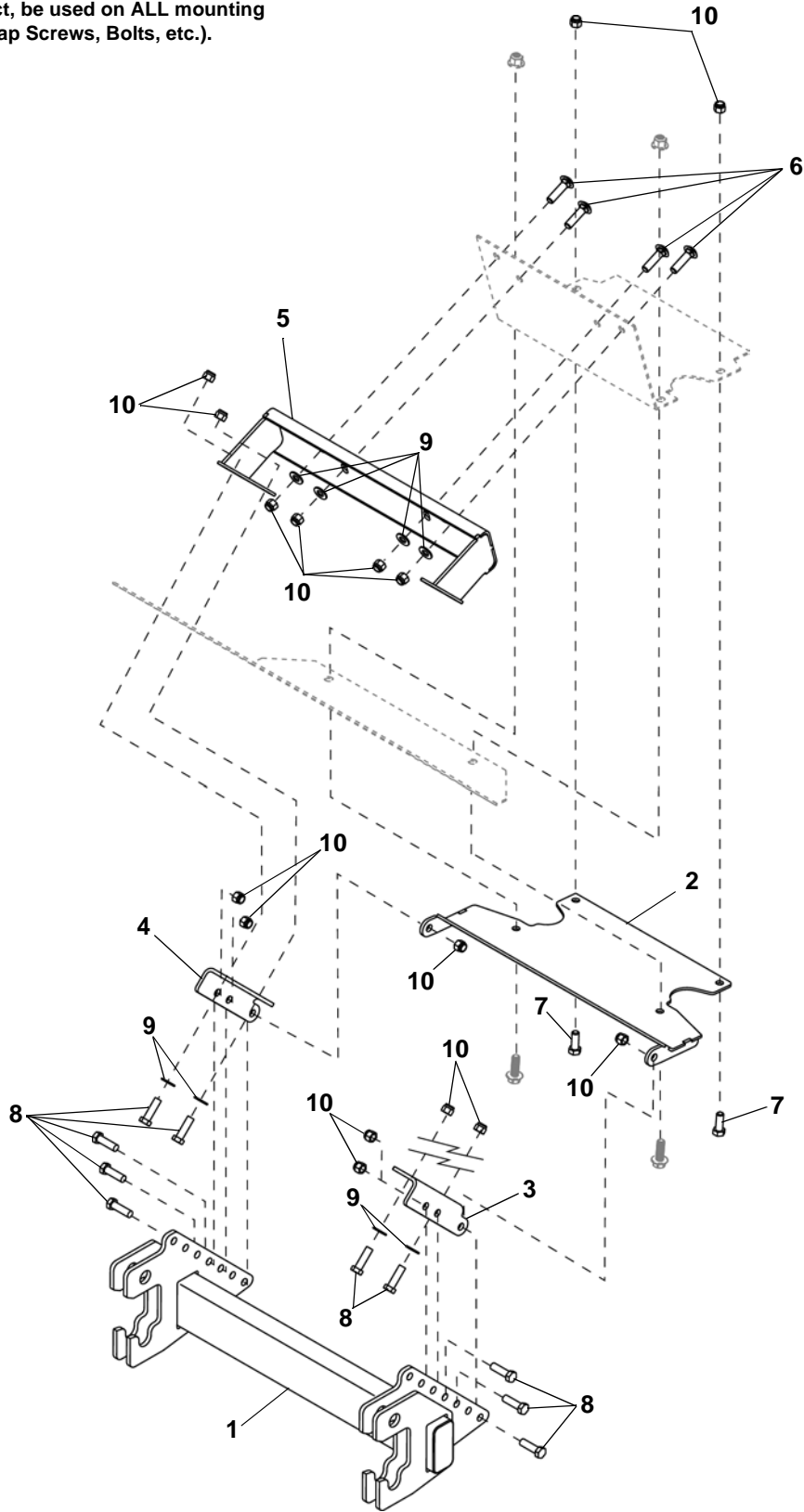

PARTS LIST

ITEM	PART NO.	DESCRIPTION	QTY.
1		UTV Polaris Mount	1
2		Weldment, Bottom Bracket, Polaris.....	1
3		Bracket, Front, DS, Polaris 900.....	1
4		Bracket, Front, PS, Polaris 900.....	1
5		Weldment, Top Bracket, Polaris 900.....	1
6		CB, 3/8"-16"-18 x 1-1/2"	4
7		HHCS, 3/8"-16 x 1"	2
8		HHCS, 3/8"-16 x 1-1/4"	10
9		PW, 3/8".....	8
10		LN, 3/8"-16	16
11	96115040	Kit, HDWE (Not Shown) (Includes Items 6-10)	1

SNO-WAY® INTERNATIONAL, INC.



Hartford, WI 53027 USA
Website: www.snoway.com
©2013 Sno-Way® International

www.storksplows.com