

SNO-WAY®

SNOW & ICE CONTROL EQUIPMENT

ASSEMBLY & INSTALLATION INSTRUCTIONS

**VEHICLE MOUNT KIT 99101133
FOR UTV SERIES PLOW**

TO FIT
2004 & Later - Kawasaki Mule 4010



©2013 Sno-Way® International

97101844A



1. THINK SAFETY, ALWAYS WEAR SAFETY GLASSES WHEN PERFORMING THE OPERATIONS PRESCRIBED IN THESE INSTRUCTIONS
2. READ ALL INSTRUCTIONS CAREFULLY BEFORE ATTEMPTING INSTALLATION
3. BEFORE BEGINNING WORK MAKE SURE TO SET PARKING BRAKE AND CHOCK WHEELS



ASSEMBLY TOOLS NEEDED

Drill Bits	1/4" - 17/32"
Impact Sockets	7/16" - 1-3/8"
Wrenches	7/16" - 1-3/8"
Torque Wrench	
Rat Tail Pry Bar	
Center Punch and Hammer	
C-Clamp	
Screwdrivers	

INSTALLATION NOTES

1. Vehicle should be parked on a level surface with a normal vehicle load on the FRONT suspension.
2. On some vehicles it may be necessary to raise or stiffen the suspension to decrease the vehicles front suspension sag with the snow plow in place.
3. Unless otherwise specified, mount all Vehicle Mount Kit Components to vehicle before tightening any hardware.
4. It is recommended that LOCTITE®, or similar thread locking product, be used on ALL mounting hardware (i.e. Nuts, Cap Screws, Bolts, etc.).
5. Items in parentheses () refer to quantity required for this step. Items in parentheses with a pound sign (#) indicate the part number as found in the parts list on the last page of this document.
Example: (2) 1/2" Lock Washers (#9).

MOUNTING INSTRUCTIONS

1. Remove fasteners from flashing on the DS and PS side of vehicle, located low and behind the brush guard.
2. Remove the skid plate from the vehicle and retain the hardware for installation in a later step.
3. Remove the two lower bolts (one on each side) mounting the brush guard to the vehicle.
4. Position Front Bracket (#2) around the brush guard and the frame the brush guard was bolted two. Align the holes of the Front Bracket (#2) with the holes in the vehicle frame and brush guard. Then insert (2) 1/2"-13 X 3-1/2" Cap Screws (#5) where the bolts were removed in step 3. Loosely secure with (2) 3/8" Plain Washers (#6) and (2) 3/8" Locknuts (#7).

5. Align the skid plate over its original mounting holes. re-attach the rear hardware for the skid plate (removed in step 2). Loosely secure the front of the skid plate with (2) 3/8"-16 x 1-1/2" Caps Screws (#12), (4) 3/8" Plain Washers (#9) and (2) 3/8" Locknuts (#10).

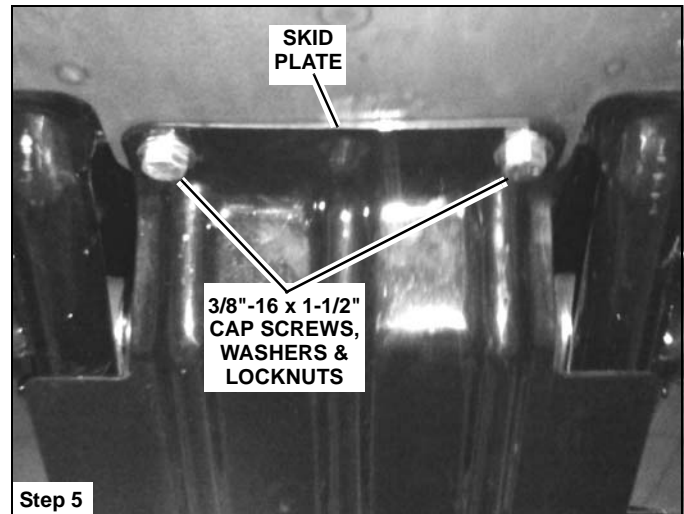
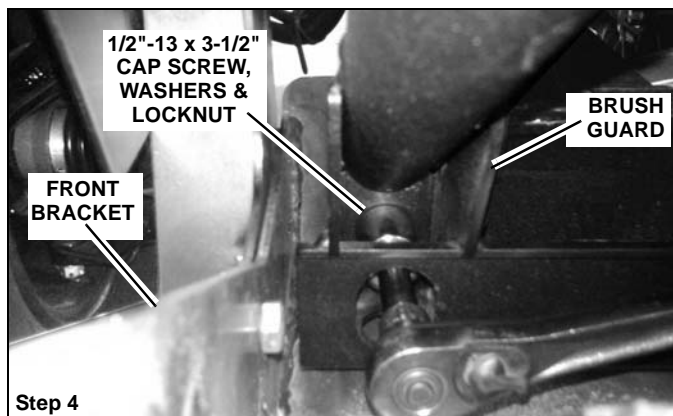

6. Tighten the hardware that was installed on steps 4 & 5.

7. Align the Passenger Side Bracket (#3) on the Front Bracket (#2) as shown below.
8. Install (2) 3/8"-16 x 1" Cap Screws (#8), (2) 3/8" Plain Washers (#9) and (2) 3/8" Locknuts (#10) through the rear holes in the Front Bracket and Side Bracket.
9. Install (1) 3/8"-16 x 1" Cap Screw (#8) and (1) 3/8" Locknut (#10) through the front hole in the Front Bracket and Side Bracket.

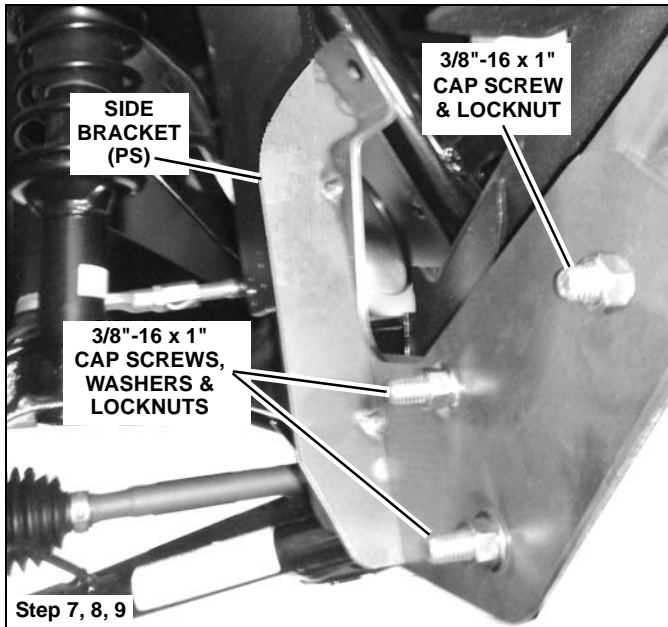

10. Place the upper flat area of the Passenger Side Bracket (#3) against the vertical tube and plate coming from the lower frame area. Position the holes so they are evenly spaced on either side of the round tube.
11. Using the Side Bracket (#3) as a template, center punch and drill a 1/4", then 13/32" hole through the plate to the rear of the vertical round tube coming from the lower frame area.
12. Repeat steps 7-11 to install the Driver Side Bracket.
13. Install (1) U-bolt (#11) in each Side Bracket (#3 & 4) and secure each with (2) 3/8" Plain Washers (#9) and (2) 3/8" Locknuts (#10).
14. Position the UTV Mount (#1) on the machine. Align the mount holes with the Front Bracket (#2) to provide an 11" to 12" height between the lower pin slots and the ground.

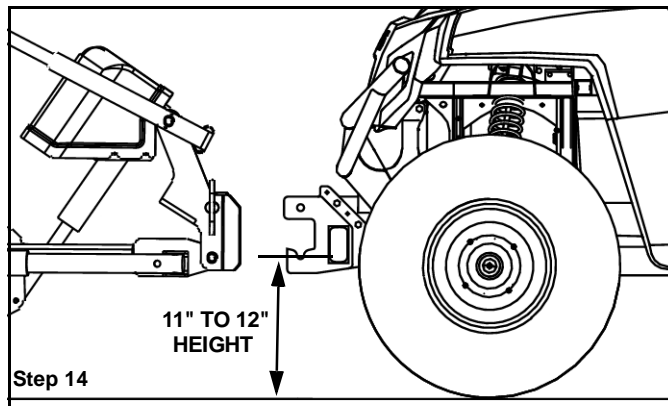

IMPORTANT: Height from the bottom of the lower pin slots on the UTV Mount to the ground should be between 11" and 12" to ensure proper operation.

15. Secure the UTV Mount (#1) to the Front Bracket (#2) using (6) 3/8"-16 x 1-1/4" Cap Screws (#13), (6) 3/8" Plain Washers (#9) and (6) 3/8" Locknuts (#10) evenly spaced on each side.

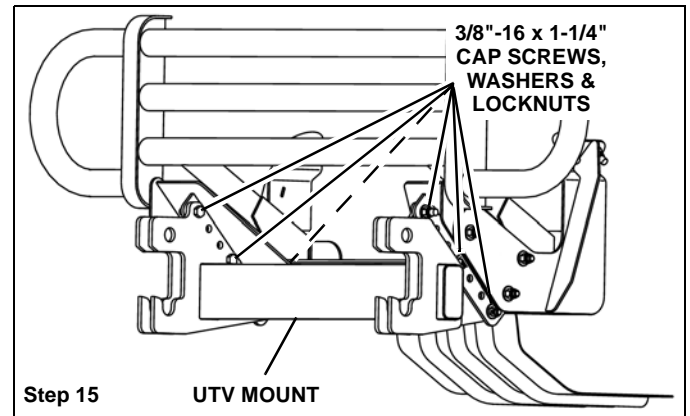

16. Torque all hardware using the Torque Specification Chart below:

TORQUE SPECIFICATIONS FOR STANDARD MACHINE HARDWARE					
Bolt Size	GR.2 Dry	GR.5 Dry	GR.8 Dry	Metric Size	GR.8.8 Dry
1/4"	66*	9	12	M8	17
5/16"	11	17	25	M10	35
3/8"	20	30	45	M12	60
7/16"	32	50	70	M14	95
1/2"	50	75	110	M16	155
9/16"	70	110	150		
5/8"	100	150	220		
3/4"	175	260	380		
7/8"	170	430	600		
1"	250	640	900		

These torque values are to be used for all hardware. Unless otherwise specified, all torque values must meet this specification.
All torque values are in Ft.-Lbs unless otherwise stated
*In-Lbs

REMEMBER After 5 to 10 hours of snowplow usage, re-torque all hardware!

17. Re-install the fasteners that were removed in step 1 and cut side plastic flashings to clear side supports as required.

PARTS LIST

Note: It is recommended that LOCTITE®, or similar thread locking product, be used on ALL mounting hardware (i.e. Nuts, Cap Screws, Bolts, etc.).

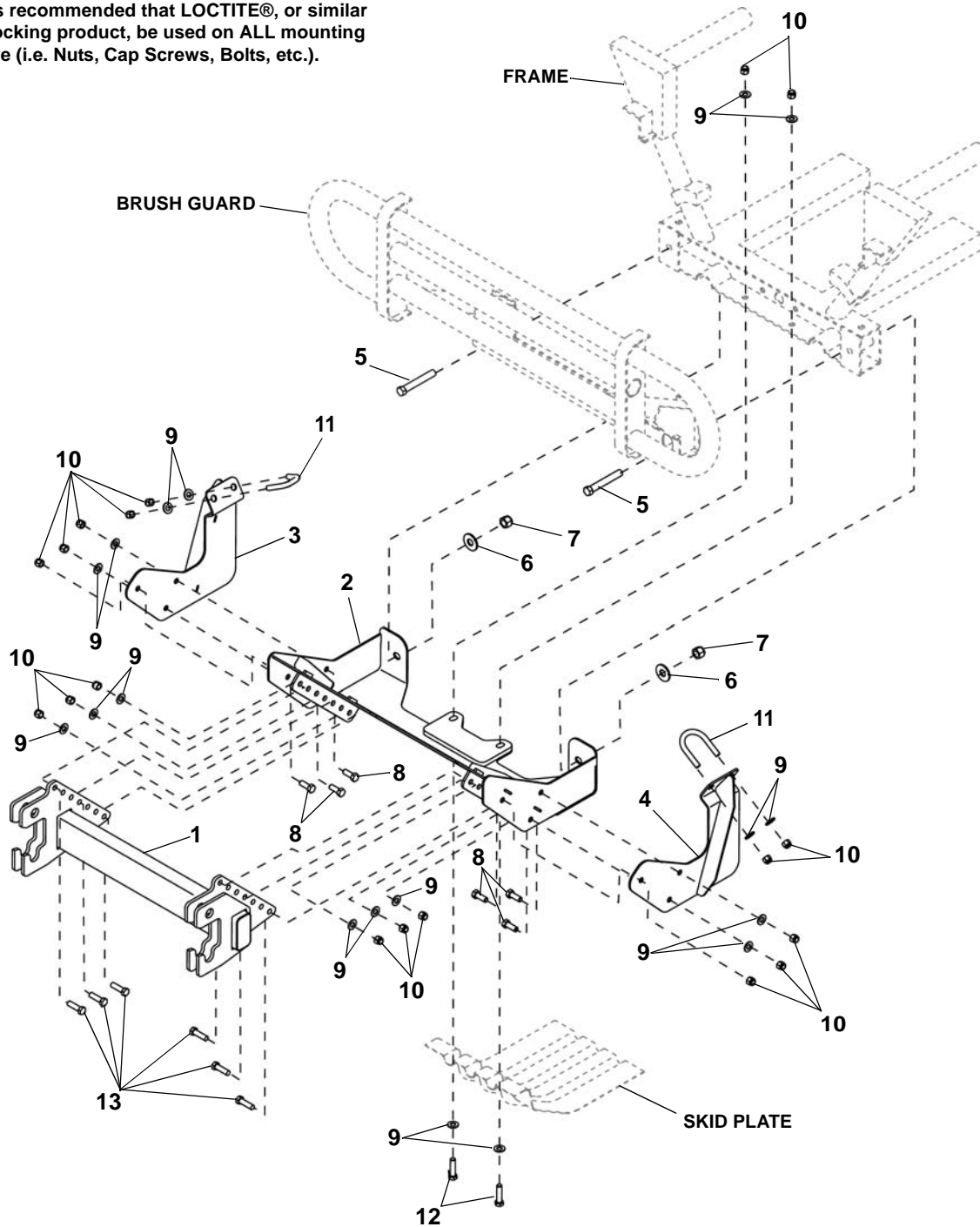

PARTS LIST

ITEM	PART NO.	DESCRIPTION	QTY.
1		UTV Mount	1
2		Weldment, Front Bracket, Kawasaki 4010	1
3		Weldment, PS Bracket, Kawasaki 4010	1
4		Weldment, DS Bracket, Kawasaki 4010	1
5		HHCS, 1/2"-13 x 3-1/2"	2
6		PW, 1/2"	2
7		LN, 1/2"-13	2
8		HHCS, 3/8"-16 x 1"	6
9		PW, 3/8"	18
10		LN, 3/8"-16	18
11		U-Bolt,	2
12		HHCS, 3/8"-16 x 1-1/2"	2
13		HHCS, 3/8"-16 x 1-1/4"	6
14	96115091	Kit, HDWE (Not Shown) (Includes Items 5-13)	1

SNO-WAY[®] INTERNATIONAL, INC.



Hartford, WI 53027 USA
Website: www.snoway.com
©2013 Sno-Way[®] International

www.storksplows.com