

SNO-WAY®

SNOW & ICE CONTROL EQUIPMENT

ASSEMBLY & INSTALLATION INSTRUCTIONS

**VEHICLE MOUNT KIT 99101134
FOR UTV SERIES PLOW**

TO FIT
2010 & Later - Kabota 1100



©2013 Sno-Way® International

97101829A



1. THINK SAFETY, ALWAYS WEAR SAFETY GLASSES WHEN PERFORMING THE OPERATIONS PRESCRIBED IN THESE INSTRUCTIONS
2. READ ALL INSTRUCTIONS CAREFULLY BEFORE ATTEMPTING INSTALLATION
3. BEFORE BEGINNING WORK MAKE SURE TO SET PARKING BRAKE AND CHOCK WHEELS



ASSEMBLY TOOLS NEEDED

Drill Bits	1/4" - 17/32"
Impact Sockets	7/16" - 1-3/8"
Wrenches	7/16" - 1-3/8"
Torque Wrench	
Rat Tail Pry Bar	
Center Punch and Hammer	
C-Clamp	
Screwdrivers	

INSTALLATION NOTES

1. Vehicle should be parked on a level surface with a normal vehicle load on the FRONT suspension.
2. On some vehicles it may be necessary to raise or stiffen the suspension to decrease the vehicles front suspension sag with the snow plow in place.
3. Unless otherwise specified, mount all Vehicle Mount Kit Components to vehicle before tightening any hardware.
4. It is recommended that LOCTITE®, or similar thread locking product, be used on ALL mounting hardware (i.e. Nuts, Cap Screws, Bolts, etc.).
5. Items in parentheses () refer to quantity required for this step. Items in parentheses with a pound sign (#) indicate the part number as found in the parts list on the last page of this document.
Example: (2) 1/2" Lock Washers (#9).

MOUNTING INSTRUCTIONS

1. Remove 4 lower M12 bolts that secure the bumper to the machine. Remove 2 M10 bolts securing the front of the bottom skid plate.

NOTE: Bolts are located just ahead of the front axle.

2. Position the rear bracket (#3) on the bottom of the machine, aligning (4) front holes with mating holes in the bumper and (2) rear holes with mating holes for the skid plate. Install (4) M12 x 40 cap screws (#4) and (4) M12 lock washers (#9) to secure the rear bracket (#3) to the bumper. Install (2) M10 X 30 cap screws (#5), (2) M10 lock washers (#8) and (2) M10 (#11) plain washers to secure the rear bracket (#3) and skid plate to the machine. Tighten all rear bracket (#3) hardware.

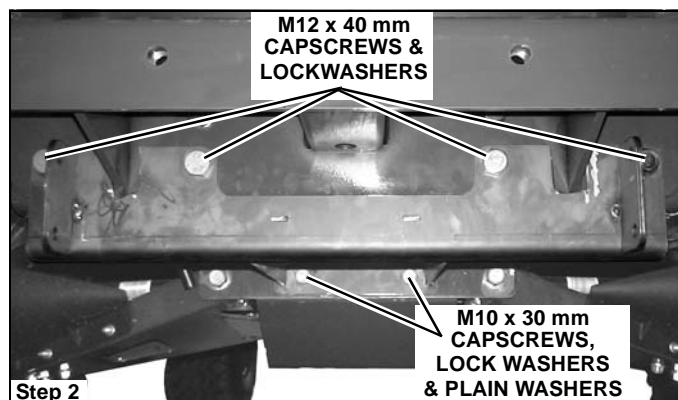

3. Position the front bracket (#2) on the machine, aligning the front two (2) holes with the holes in the bumper. Install (2) M12 x 40 cap screws (#4) with (2) M12 lock washers (#9) through front bracket (#2) and into bumper.
4. Secure each side of the front bracket (#2) to the rear bracket with (2) 3/8 x 1-1/4" cap screws (#6), (2) 3/8" plain washers (#10) and (2) 3/8" lock nuts (#7). Tighten all front bracket (#2) hardware.

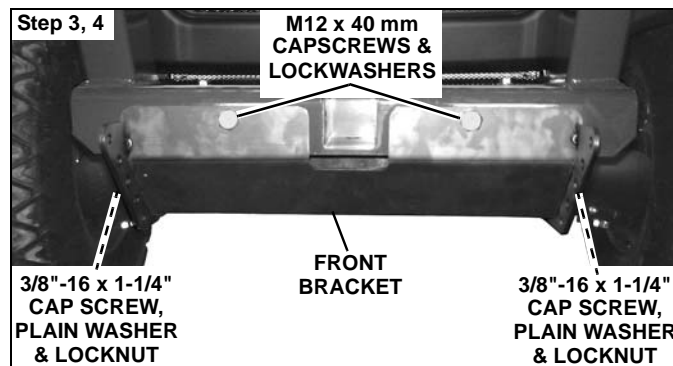

5. Position the UTV Mount (#1) on the machine. Align the Mount holes with the front bracket (#2) to provide an 11" to 12" height between the lower pin slots and the ground.

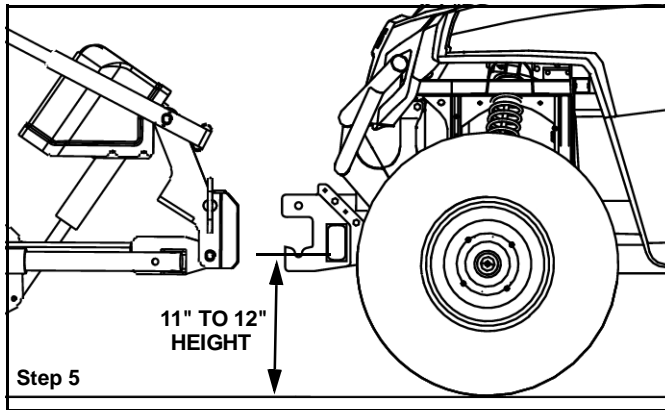

IMPORTANT: Height from the bottom of the lower pin slots on the UTV Mount to the ground should be between 11" and 12" to ensure proper operation.

6. Secure the UTV Mount (#1) to the front bracket (#2) using (6) 3/8"-16 x 1-1/4" cap screws (#6) and (6) 3/8" locknuts (#7).

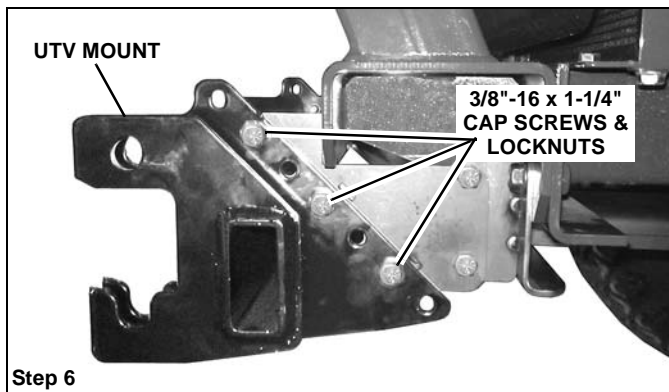

7. Torque all hardware using the Torque Specification Chart below:

TORQUE SPECIFICATIONS FOR STANDARD MACHINE HARDWARE					
Bolt Size	GR.2 Dry	GR.5 Dry	GR.8 Dry	Metric Size	GR.8.8 Dry
1/4"	66*	9	12	M8	17
5/16"	11	17	25	M10	35
3/8"	20	30	45	M12	60
7/16"	32	50	70	M14	95
1/2"	50	75	110	M16	155
9/16"	70	110	150		
5/8"	100	150	220		
3/4"	175	260	380		
7/8"	170	430	600		
1"	250	640	900		

These torque values are to be used for all hardware. Unless otherwise specified, all torque values must meet this specification.
All torque values are in Ft.-Lbs unless otherwise stated
*In-Lbs

REMEMBER After 5 to 10 hours of snowplow usage, re-torque all hardware!

PARTS LIST

Note: It is recommended that LOCTITE®, or similar thread locking product, be used on ALL mounting hardware (i.e. Nuts, Cap Screws, Bolts, etc.).

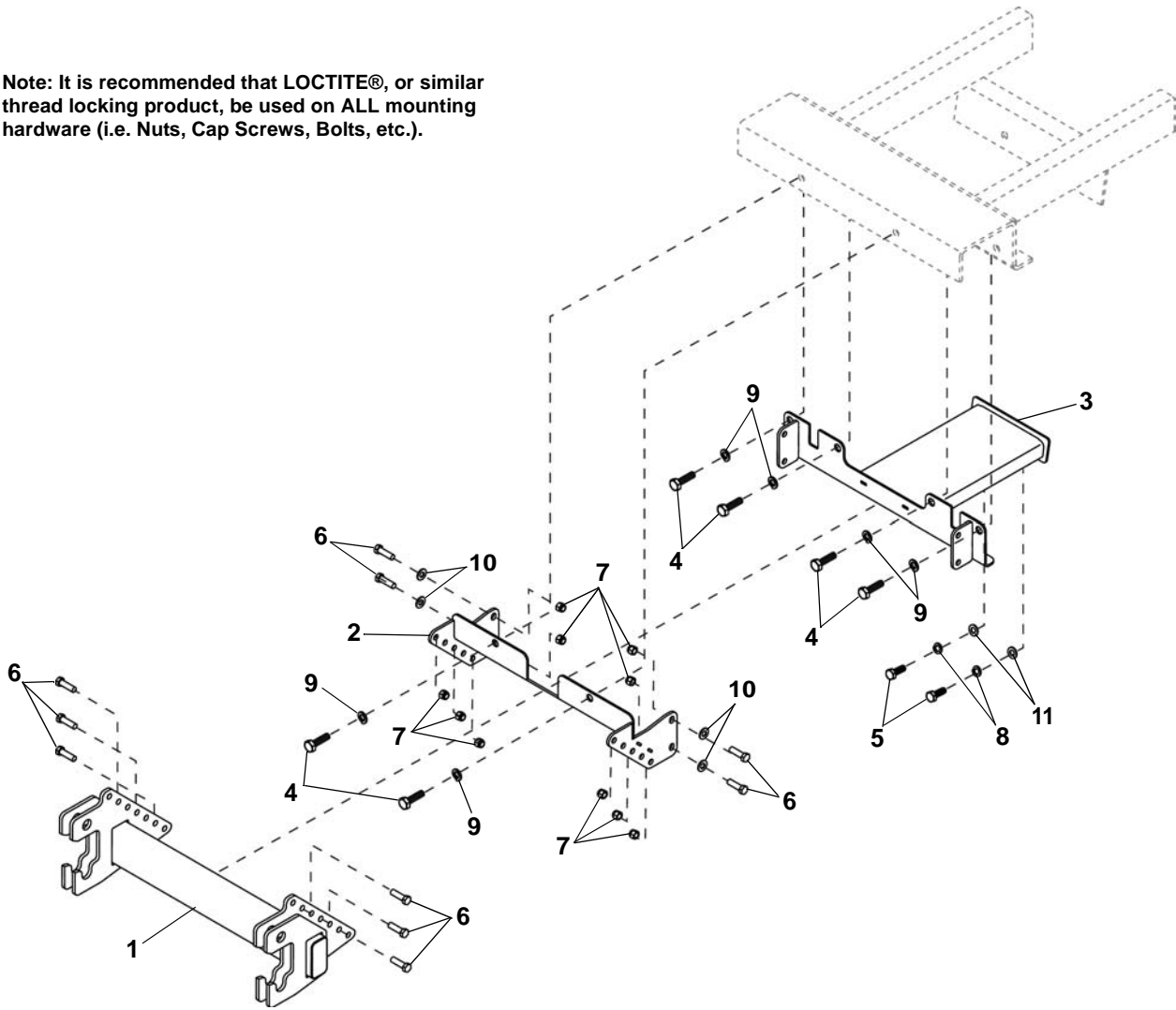

PARTS LIST

ITEM	PART NO.	DESCRIPTION	QTY.
1		UTV Mount	1
2		Weldment, Front Bracket, Kubota 1100.....	1
3		Weldment, Rear Bracket, Kubota 1100	1
4		HHCS, M12-1.25 x 40 mm	6
5		HHCS, M10-1.25 x 30 mm	2
6		HHCS, 3/8"-16 x 1-1/4"	10
7		LN, 3/8"-16	10
8		LW, M10	2
9		LW, M12	6
10		PW, 3/8".....	4
11		PW, M10.....	2
12	96115091	Kit, HDWE (Not Shown) (Includes Items 4-11).....	1

SNO-WAY[®] INTERNATIONAL, INC.



Hartford, WI 53027 USA
Website: www.snoway.com
©2013 Sno-Way[®] International

www.storksplows.com