

SNO-WAY®

SNOW & ICE CONTROL EQUIPMENT

ASSEMBLY & INSTALLATION INSTRUCTIONS

**VEHICLE MOUNT KIT 99101169
AND
VEHICLE CENTER MEMBER 99101139**

**TO FIT
2010- RAM 2500 - 3500 PICKUP**

Sno-Way®, Down Pressure® and EIS® are registered trademarks of Sno-Way International, Inc.
ProControl™, MegaBlade™, V-Wing™, E-Z Switch™, Revolution™, MaxAdjust™, SpeedLock™, and QuickJack™
are trademarks of Sno-Way International, Inc.

©2013 Sno-Way® International

97101858A



1. **THINK SAFETY, ALWAYS WEAR SAFETY GLASSES WHEN PERFORMING THE OPERATIONS PRESCRIBED IN THESE INSTRUCTIONS**
2. **READ ALL INSTRUCTIONS CAREFULLY BEFORE ATTEMPTING INSTALLATION**
3. **BEFORE BEGINNING WORK MAKE SURE TO SET PARKING BRAKE AND CHOCK WHEELS**



MINIMUM VEHICLE RECOMMENDATIONS

- Heavy Duty Alternator
- Heavy Duty Battery
- Manufacturer's Snow Plow Package

NOTE: On some vehicles it may be necessary to use a form of load booster to decrease the vehicle's front suspension sag with the snow plow in place. This can be accomplished with the use of supplementary air bags, booster springs, or similar load boosting devices. Since there are different load boosting devices available, it will up to the customer/end user to decide and purchase the product to suit the

ASSEMBLY TOOLS NEEDED

- Drill Bits 1/4", 17/32", 21/32"
- Impact Sockets 7/16" - 1-3/8"
- Metric Sockets 10mm - 18mm
- Wrenches 7/16" - 1-3/8"
- Metric Wrenches 10mm - 18mm
- Torque Wrench
- Center Punch and Hammer
- Hacksaw

INSTALLATION NOTES

1. **Unless otherwise specified, mount all Vehicle Mount Kit Components to vehicle before tightening any hardware.**
2. It is recommended that LOCTITE®, or similar thread locking product, be used on ALL mounting hardware (i.e. Nuts, Cap Screws, Bolts, etc.).
3. Vehicle should be parked on a level surface with a normal vehicle load on the FRONT suspension.
4. Items in parentheses () refer to quantity required for this step. Items in parentheses with a pound sign (#) indicate the part number as found in the parts list on the last page of this document.
Example: (2) 1/2" Lock Washers (#9).
5. It maybe necessary to relocate license plate holder. Check state and local laws for placement, if needed.

MOUNTING INSTRUCTIONS

1. Remove the mounting hardware attaching the truck bumper and tow hooks to the bumper brackets.
2. Remove hardware and Frontal Crash Bracket from each side of truck. Keep brackets and hardware for installation on truck if subframe is removed at a later date.

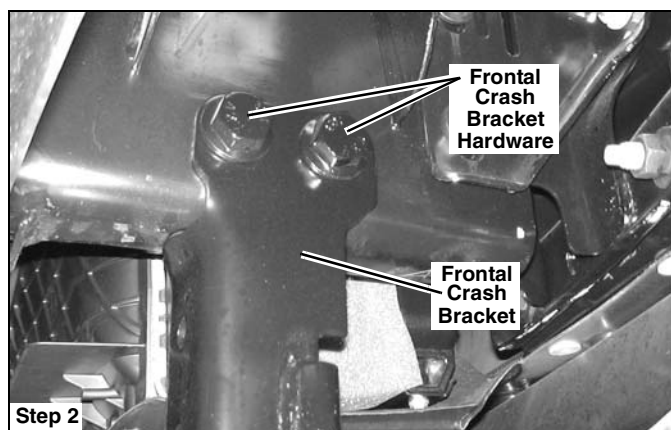

- Remove the hardware securing the bumper mounting brackets to the truck frame.

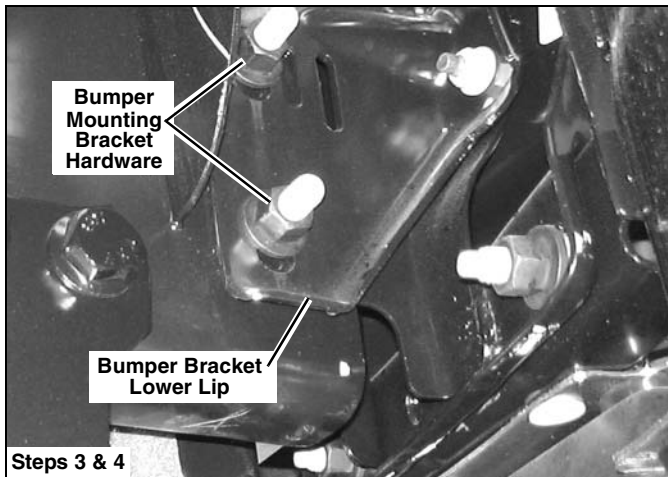

- Grind the lower lip flat on both the PS and DS bumper brackets, to prevent interference when each side weldment is positioned over the respective bracket slots.
- Align the Front Mtg Weldment, DS (#3) over the mount bolts for the bumper bracket. Then in the rear 5/8" hole of the Front Mtg Weldment, place (1) 5/8" Flat Washer (#10) between the weldment and the truck frame rail. Align the 5/8" hole in the Front Mtg Weldment, 5/8" Flat Washer, and truck frame rail with (1) 5/8"-11 x 4" Cap Screw (#8).
- Place the Front Mtg Weldment tight against the bumper mounting bracket and truck frame. Using the Front Mtg Weldment as a template, drill 1/4", then 17/32" hole through the bottom of the truck frame. Then remove the weldment from the truck frame.
- Repeat steps 5 & 6 for the Passenger Side.

NOTE: For gas engines and 2010-12 diesel engines, remove the remaining bumper mounting bracket hardware and then skip to step 13. For 2013 and later diesel engines, continue to step 8.

- Remove the intercooler mounting brackets from the truck frame (2 bolts per side). Once the hardware is removed, allow the intercooler to drop down and hang. (located near the top of the frame rail just behind the bumper mounting brackets)
- Remove the 4 bolts and 3 plastic fasteners, attaching the intercooler shroud to the back of the intercooler. Retain for installation in a later step.

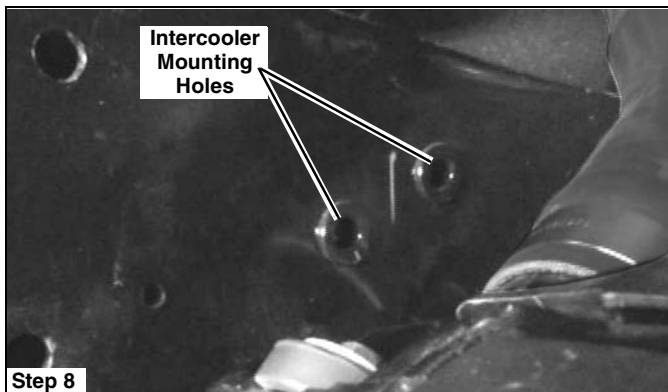

- Remove the hardware attaching the driver side intercooler mounting bracket to the intercooler. Then, let the mounting bracket slip down and out of the way for the next step.

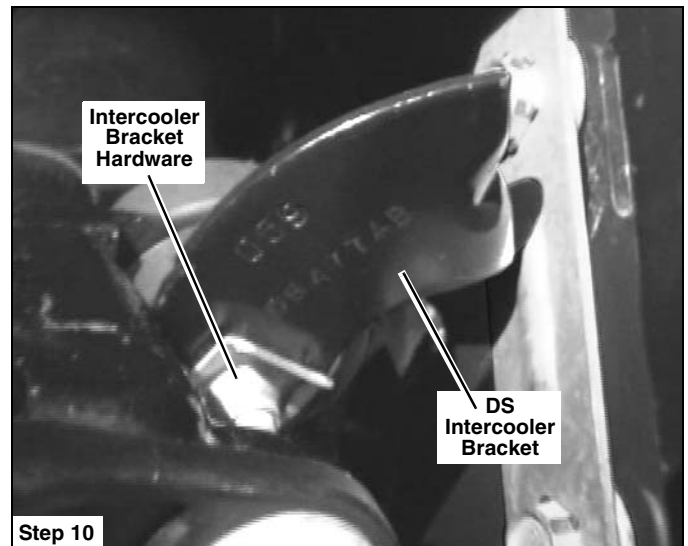

- Remove the remaining bumper mounting bracket hardware.

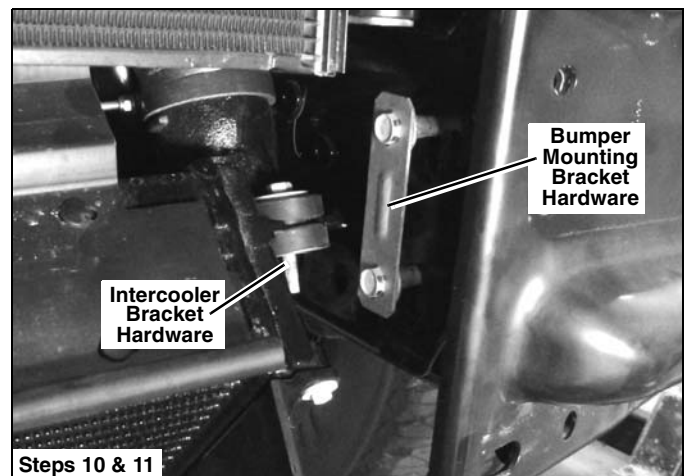

- Re-attach the intercooler and intercooler shroud by following steps 8-10 in reverse order
- Install the Front Mtg Weldment, DS (#3) by inserting (2) 1/2"-13 x 4" Cap Screws (#7) through the two front holes of the Front Mtg Weldment, bumper mounting bracket and truck frame rail. Loosely secure with (2) 1/2" Flat Washers (#9) and (2) 1/2" Nylock Nuts (#12).
- Insert (1) 5/8"-11 x 4" Cap Screw (#8) through (1) 5/8" Flat Washer (#10), the rear 5/8" hole in the Front Mtg Weldment, (1) 5/8" Flat Washer (#10), and then the truck frame rail. Loosely secure with (1) 5/8" Flat Washer (#10) and (1) 5/8" Nylock Nut (#13).
- Insert (1) 1/2"-13 x 1-1/2" Cap Screw (#6) through (1) 1/2" Lock Washer (#11), Front Mtg Weldment (#3), and truck frame rail. Secure loosely using a (1) Nut Wire Assembly (#14) inserted from the front end of the truck frame rail.
- Install the Front Mtg Weldment, PS (#2) by repeating steps 13-15.

17. Install the Vehicle Center Member (#1) between the Front Mtg Weldments (#2 and #3) using (8) ½”-13 x 1-1/2” Caps Screws (#6), (2) ½” Lock Washers (#11), and (6) ½” Nylock Nuts (#12).
18. Remove the hardware attaching the swaybar bushing bracket to the frame.
19. Slip the Rear Mtg. Weldments, DS (#4) and PS (#5) over the swaybar and swaybar bushing bracket.
20. Assemble the Rear Mtg., Weldments onto the Front Mtg. Weldments (#2 and #3). Then secure each side using (2) ½”-13 x 1-1/2” Cap Screws (#6), and (2) ½”-13 Nylock Nuts (#12).
21. Attach the Rear Mtg. Weldments to where the swaybar was once attached. Place the Spacer Plate (#15) (one per side) between the swaybar bushing and the frame rail. Then loosely secure with (4) 3/8” Flat Washers (#16), (4) M10 Lock Washers (#17), and (4) M10-1.5 x 35 Cap Screws (#18).
22. With all components in place, tighten all hardware. The mounting hardware for the Front Mtg Weldments should be tightened first then the remaining hardware. **(DO NOT over-tighten the upper mounting hardware for the Rear Mtg Weldments, as over-tightening could crush the frame rails!)**
23. Using the torque specification chart provided, torque all cap screws.

REMEMBER After 5 to 10 hours of snowplow usage, re-torque all Cap Screws!

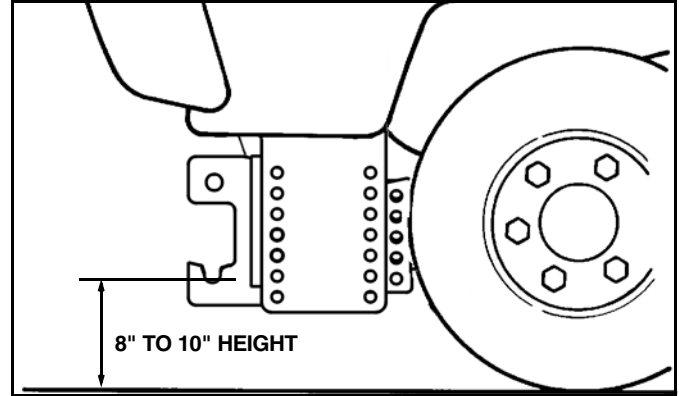

IMPORTANT: Height from the bottom of the lower pin slots on the Subframe to the ground should be between 8" and 10" to ensure proper operation.

TORQUE SPECIFICATIONS FOR STANDARD MACHINE HARDWARE					
Bolt Size	GR.2 Dry	GR.5 Dry	GR.8 Dry	Metric Size	GR.8.8 Dry
1/4"	66*	9	12	M8	17
5/16"	11	17	25	M10	35
3/8"	20	30	45	M12	60
7/16"	32	50	70	M14	95
1/2"	50	75	110	M16	155
9/16"	70	110	150		
5/8"	100	150	220		
3/4"	175	260	380		
7/8"	170	430	600		
1"	250	640	900		

These torque values are to be used for all hardware. Unless otherwise specified, all torque values must meet this specification.
All torque values are in Ft.-Lbs unless otherwise stated
*In-Lbs

PARTS LIST

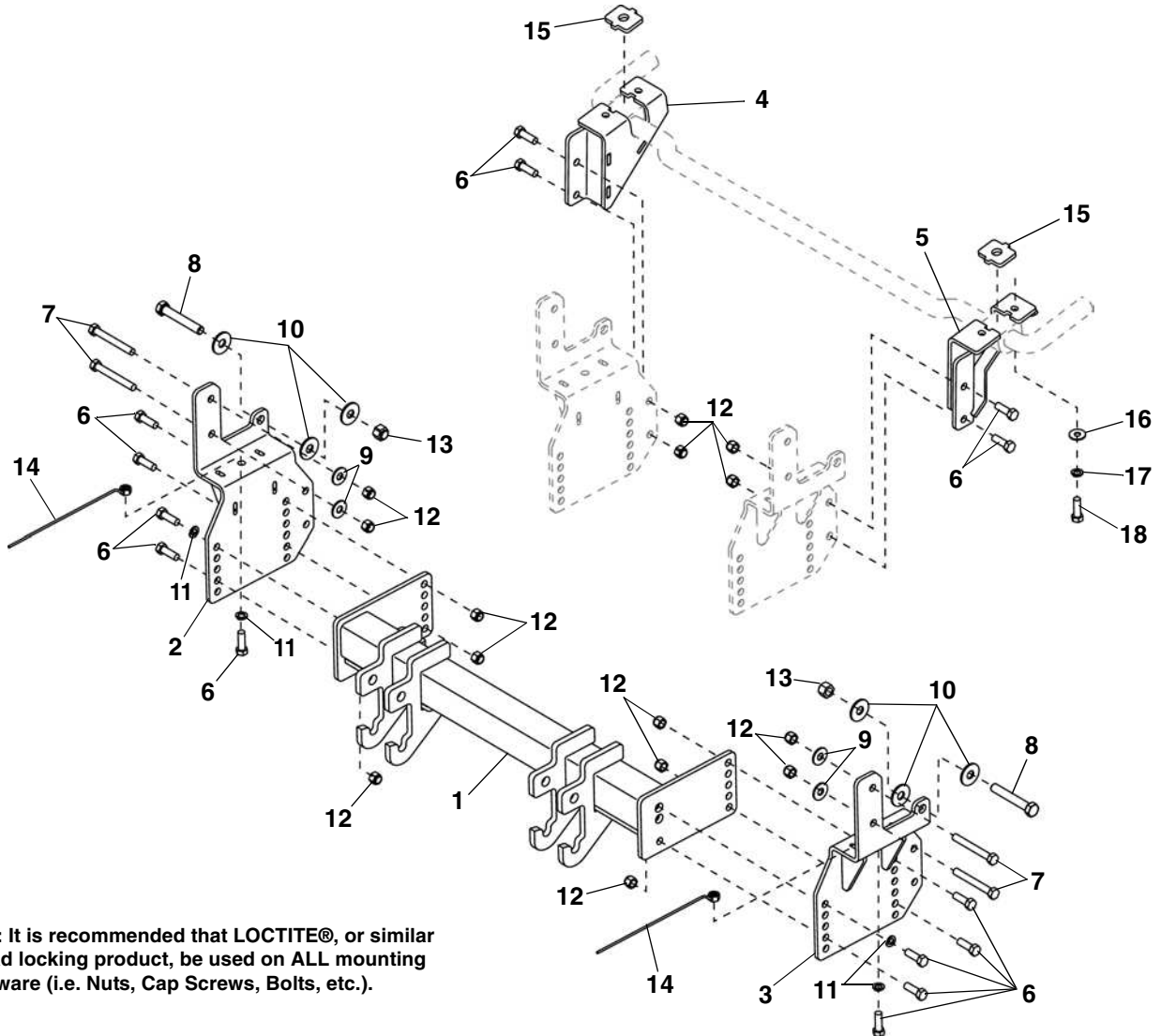

Note: It is recommended that LOCTITE®, or similar thread locking product, be used on ALL mounting hardware (i.e. Nuts, Cap Screws, Bolts, etc.).

ITEM	PART NO.	DESCRIPTION	QTY.
1	99101139	Vehicle Center Member (96114990)	1
2		Front Mtg Weldment, PS	1
3		Front Mtg Weldment, DS	1
4		Rear Mtg Weldment, PS	1
5		Rear Mtg Weldment, DS	1
6		Hex Head Cap Screw, 1/2"-13 x 1-1/2"	14
7		Hex Head Cap Screw, 1/2"-13 x 4"	4
8		Hex Head Cap Screw, 5/8"-11 x 4"	2
9		Flat Washer, 1/2"	4
10		Flat Washer, 5/8"	6
11		Lock Washer, 1/2"	4
12		Nylock Nut, 1/2"-13	14
13		Nylock Nut, 5/8"-11	2
14		Nut Wire Assembly	2
15		Plate, Spacer	2
16		Flat Washer, 3/8"	4
17		Lock Washer, M10	4
18		Hex Head Cap Screw, M10-1.5 x 35	4
19	96115164	Kit, HDWE (Includes Items 6-18)	1

SNO-WAY® INTERNATIONAL, INC.



Hartford, WI 53027 USA
Website: www.snoway.com
©2013 Sno-Way® International

www.storksplows.com