

SNO-WAY®

SNOW & ICE CONTROL EQUIPMENT

ASSEMBLY & INSTALLATION INSTRUCTIONS

**VEHICLE MOUNT KIT 99101198
AND
VEHICLE CENTER MEMBER 96100950**

**TO FIT
2008 - 2016 FORD F250-F550 4X4**

Sno-Way®, Down Pressure® and EIS® are registered trademarks of Sno-Way International, Inc.
ProControl™, MegaBlade™, V-Wing™, E-Z Switch™, Revolution™, MaxAdjust™, SpeedLock™, and QuickJack™
are trademarks of Sno-Way International, Inc.

©2020 Sno-Way® International

97101920C



1. **THINK SAFETY, ALWAYS WEAR SAFETY GLASSES WHEN PERFORMING THE OPERATIONS PRESCRIBED IN THESE INSTRUCTIONS**
2. **READ ALL INSTRUCTIONS CAREFULLY BEFORE ATTEMPTING INSTALLATION**
3. **BEFORE BEGINNING WORK MAKE SURE TO SET PARKING BRAKE AND CHOCK WHEELS**



MINIMUM VEHICLE RECOMMENDATIONS

Heavy Duty Alternator
Heavy Duty Battery

ASSEMBLY TOOLS NEEDED

Drill Bits	17/32"
Impact Sockets	7/16" – 1-3/8" 10mm – 18mm
Wrenches	7/16" – 1-3/8" 10mm – 18mm
Torque Wrench	
Rat Tail Pry Bar	

NOTE: On some vehicles it may be necessary to use a form of load booster to decrease the vehicle's front suspension sag with the snow plow in place. This can be accomplished with the use of supplementary air bags, booster springs, or similar load boosting devices. Since there are different load boosting devices available, it will up to the customer/end user to decide and purchase the product to suit the application, and not the responsibility of Sno-Way International, Inc.

INSTALLATION NOTES

1. **Unless otherwise specified, mount all Vehicle Mount Kit Components to vehicle before tightening any hardware.**
2. **It is recommended that LOCTITE®, or similar thread locking product, be used on ALL mounting hardware (i.e. Nuts, Cap Screws, Bolts, etc.).**
3. Vehicle should be parked on a level surface with a normal vehicle load on the FRONT suspension.
4. Items in parentheses () refer to quantity required for this step. Items in parentheses with a pound sign (#) indicate the part number as found in the parts list on the last page of this document.
Example: (10) Washer, Lock, 1/2" (#8).
5. It maybe necessary to relocate license plate holder. Check state and local laws for placement, if needed.

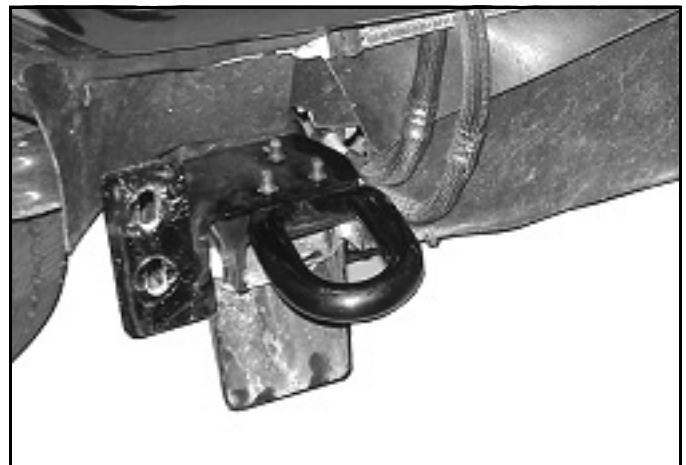

Figure 1

MOUNTING INSTRUCTIONS

1. Remove the air dam and bumper from the vehicle. Retain fasteners for installation later.
2. **2011 & Later Super Duty Models Only:**
 - A. After the bumper is removed, continue the installation process by removing the removable blocker beams. Note: There is one located on each side of the frame rail. See Figure 1 and 2. Retain blocker beams and hardware for future installation.



Figure 2

B. Install a stack of washers between the cooler plate and the frame rail. The washers should have a minimum height of .367" or enough that the cooler has clearance between it and the sub-frame Passenger Side Weldment. It is recommended that a washer with an outside diameter of 1.5" is used. The inside diameter is not critical as long as the bolt passes through it. Most 1/2" washers meet this criteria. It is recommended that when reviewing the sub-frame fastener tension every 5 to 10 hours you review this hardware also. See Figures 3 and 4. Note: For representation purposes three washers per bolt have been modeled. Depending on the thickness of your washers this may vary.



Figure 3

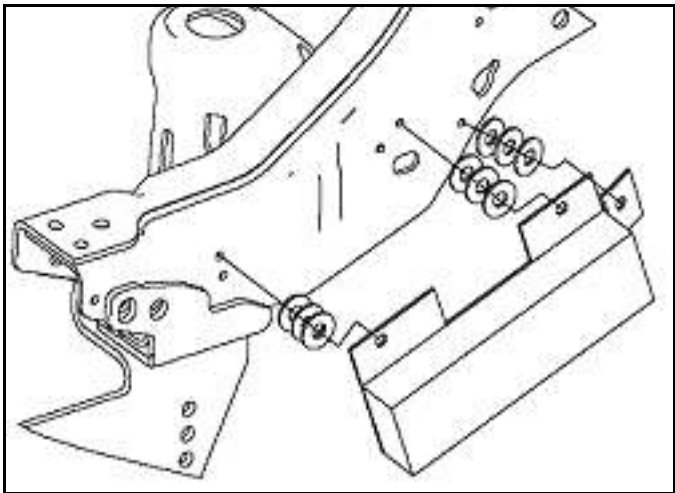

Figure 4

3. Remove the metal sway bar brackets and retain for reinstallation in a later step.
4. Completely remove the sway bar fasteners and bolt clips from the keyholes in the truck frame. Retain hardware for reinstallation if the vehicle mount kit is removed from the vehicle.
5. Install (1) Rear Side Weldment, LH (#6), aligning the appropriate holes in the frame with the holes in the Rear Side Weldment. Then place the sway bar in position. Insert (2) 7/16"-20 x 2-1/2" Cap Screws (#13) through (2) 7/16" Flat Washers (#14), then through the sway bar brackets, Rear Side Weldment, and the truck frame.

6. While holding the items in step 5 in position, place (1) Spacer Plate (#8) inside the drivers side of the truck frame, over top the (2) 7/16" -20 x 2-1/2" Cap Screws (#13) sticking through the frame. Then loosely attach (2) 7/16" Flat Washers (#14) and (2) 7/16" Nylock Nuts (#15). (For F450/F550 applications 2 more 7/16" Flat Washers are used.)
7. Insert (1) 5/8"-11 x 2" Cap Screws (#17) and (1) 5/8" Flat Washer (#19) into the truck frame and out through the hole on the side of the Rear Side Weldment, LH. Attach using (1) 5/8" Flat Washer (#19) and (1) 5/8" Nylock Nut (#20) and hand tighten.
8. Position (1) Front Side Weldment, LH (#2) so that the holes align with the holes in the front of the frame. In the holes on the inside of the frame insert from inside of frame (2) 1/2"-13 x 1-1/2" Cap Screws (#9) and secure with (4) 1/2" Flat Washers (#10) (2) on the inside of the frame and (2) used on the outside of the Front Side Weldment and (2) 1/2" Nylock Nuts (#12). Secure the front hole on the outside of the truck frame by using (1) 1/2"-13 x 1-1/2" Cap Screws (#9), (2) 1/2" Flat Washers (#10) (inside and outside of the frame) and (1) 1/2" Nylock Nuts (#12). Secure the rear angled slot using (1) 5/8"-11 x 2" Cap Screw (#17), (2) 5/8" Flat Washers (#19) (on the inside and the outside of the frame) and (1) 5/8" Nylock Nut (#20).
9. Position (1) Plate Adjustment, LH (#4) to the outside of the Rear Side Weldment, LH and to the inside of the Front Side Weldment, LH. Align the rear holes with the holes in the Rear Side Weldment, LH and attach using (4) 1/2"-13 x 1-1/2" Cap Screws (#9) and (4) 1/2" Nylock Nuts (#12).
10. Repeat Steps 5-9 on the passenger side of the vehicle.
11. Position (1) Front Side Weldment, RH (#3) so that the holes align with the holes in the front of the frame. In the holes on the inside of the frame insert from inside of frame (2) 1/2"-13 x 1-1/2" Cap Screws (#9) and secure with (4) 1/2" Flat Washers (#10) (2) on the inside of the frame and (2) used on the outside of the Front Side Weldment and (2) 1/2" Nylock Nuts (#12). Secure the front hole on the outside of the truck frame by using (1) 1/2"-13 x 1-1/2" Cap Screws (#9), (2) 1/2" Flat Washers (#10) (inside and outside of the frame) and (1) 1/2" Nylock Nuts (#12). Secure the rear angled slot using (1) 5/8"-11 x 2" Cap Screw (#17), (2) 5/8" Flat Washers (#19) (on the inside and the outside of the frame) and (1) 5/8" Nylock Nut (#20).
12. Position (1) Plate Adjustment, RH (#5) to the outside of the Rear Side Weldment, RH and to the inside of the Front Side Weldment, RH. Align the rear holes with the holes in the Rear Side Weldment, RH and attach using (4) 1/2"-13 x 1-1/2" Cap Screws (#9) and (4) 1/2" Nylock Nuts (#12).

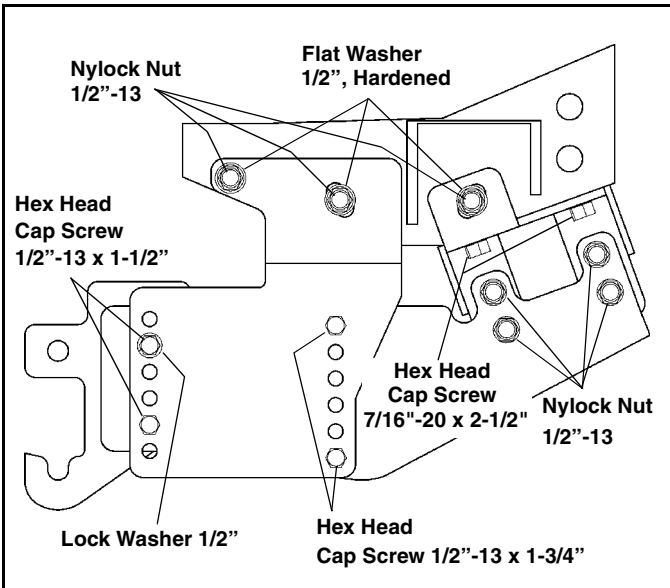

Figure 5

13. Install (1) Vehicle Center Mtg. (#1). The front holes should align with the front holes in the Front Side Weldments LH and RH. Secure the front holes using (4) 1/2"-13 x 1-1/2" Cap Screws (#9), in the threaded holes (2) 1/2" Lock Nut (#11) and (2) 1/2" Nylock Nuts (#12). Position the rear holes on the Vehicle Center Mtg. between the Front Side Weldments LH and RH and the Plate Adjustments LH and RH, secure using (4) 1/2"-13 x 1-3/4" Cap Screws (#16) and (4) 1/2" Nylock Nuts (#12).

14. Fully tighten all the Cap Screws on the Rear Side Weldments, LH and RH, then fully tighten the Cap Screws on the Front Side Weldments, LH and RH, finally tighten all the Cap Screws on the Plate Adjustments, LH and RH all using the torque specification chart provided.

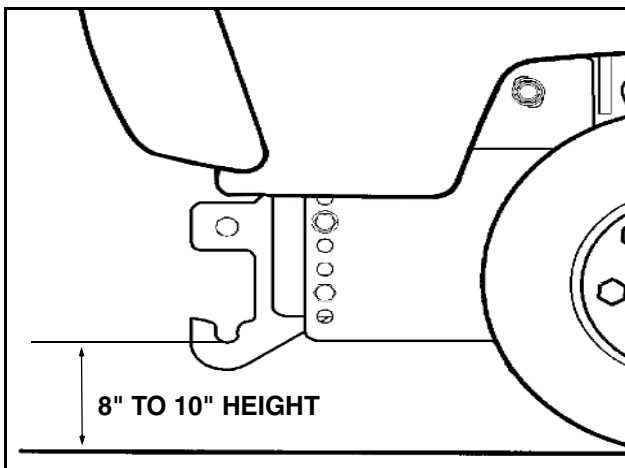

Figure 6

IMPORTANT: Height from the center of the lower Plow Mounting holes on the Vehicle Mount Kit to the ground should be between 8" and 10" to ensure proper operation.

15. Remove the plastic bracket holding the metal cooler lines from the passenger side of the truck frame. Stack (3) 1/2" Flat Washers (#10) over the bracket fastener.
16. Reinsert the fastener into the original hole to hold its position. Wrap (1) tie strap (#18) around the entire frame and tubing behind the bracket. Do not wrap tie strap over any other wires or tubes or go inside the truck frame. An extra tie strap (#18) is included.

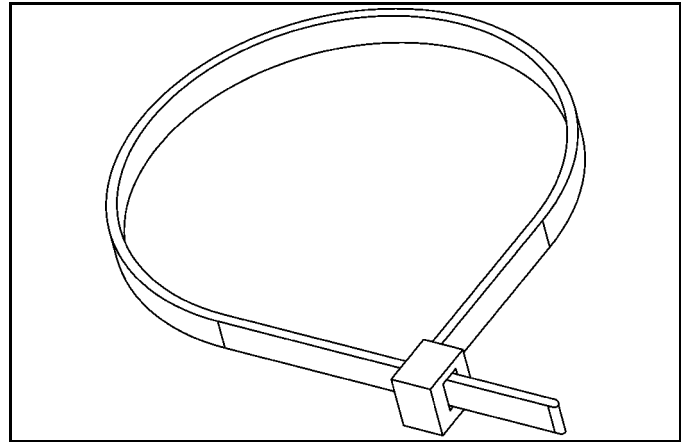

Figure 7 Tie Strap

17. Tighten tie strap until it is snug making sure not to crimp the tubing. Trim excess length if needed.
18. Reattach the bumper with original hardware. Retain air dam and its hardware if the vehicle mount kit is ever removed.

TORQUE SPECIFICATIONS FOR STANDARD MACHINE HARDWARE

Bolt Size	GR.2 Dry	GR.5 Dry	GR.8 Dry	Metric Size	GR.8.8 Dry
1/4"	66*	9	12	M8	17
5/16"	11	17	25	M10	35
3/8"	20	30	45	M12	60
7/16"	32	50	70	M14	95
1/2"	50	75	110	M16	155
9/16"	70	110	150		
5/8"	100	150	220		
3/4"	175	260	380		
7/8"	170	430	600		
1"	250	640	900		

Note: These torque values are to be used for all hardware. Unless otherwise specified, all torque values must meet this specification.
 Note: All torque values are in Ft.-Lbs unless otherwise stated
 Note: *In-Lbs

REMEMBER After 5 to 10 hours of snowplow usage, re-torque all Cap Screws!

PARTS LIST

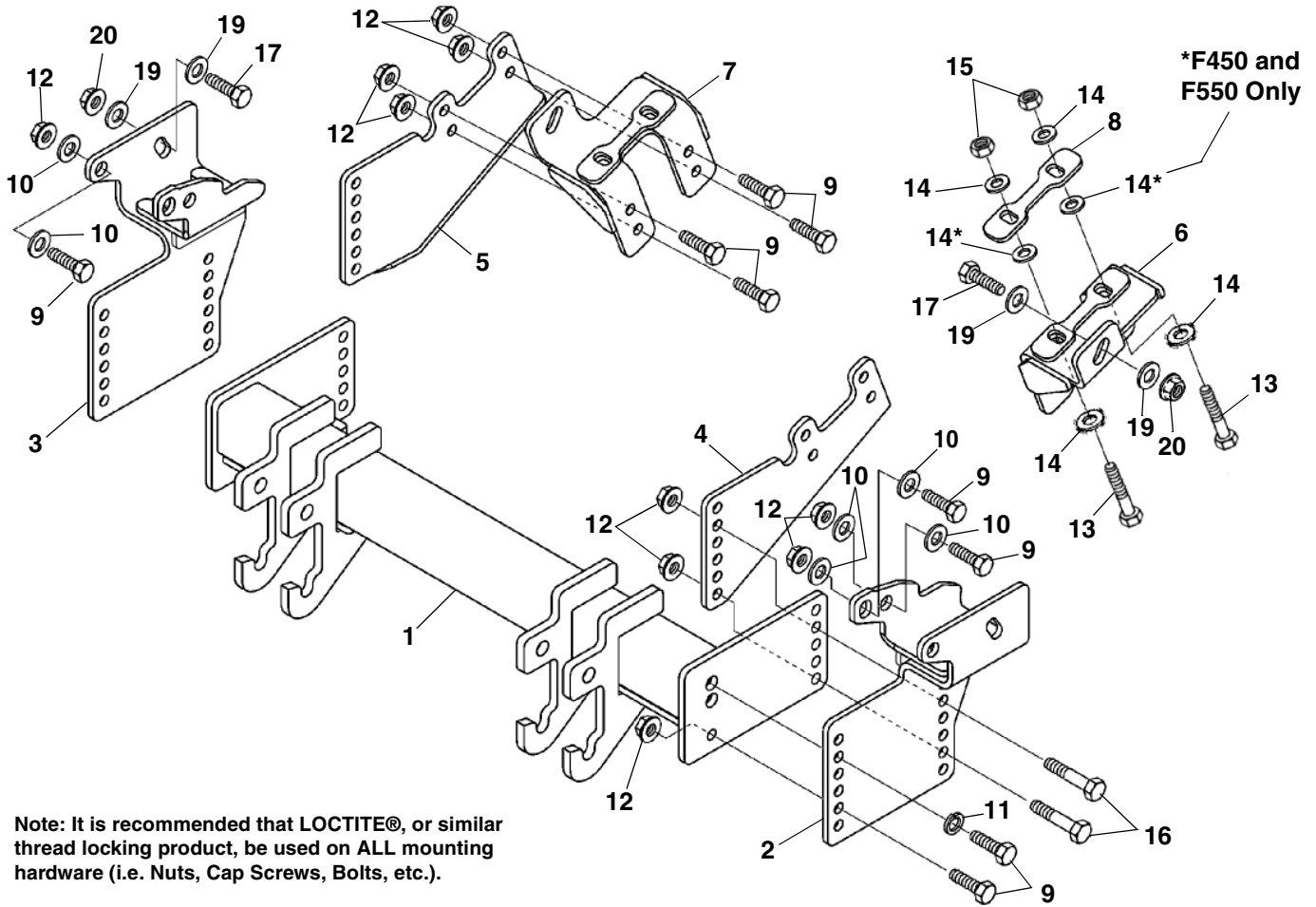

ITEM	PART NO.	DESCRIPTION	QTY.
1	99100950	Vehicle Center Mtg, Ford	1
2		Front Side Weldment, LH.....	1
3		Front Side Weldment, RH	1
4		Plate Adjustment, LH	1
5		Plate Adjustment, RH	1
6		Rear Side Weldment, LH	1
7		Rear Side Weldment, RH.....	1
8		Spacer Plate	2
9		HHCS, 1/2"-13 x 1-1/2"	18
10		PW, 1/2", Hardened	12
11		LW, 1/2"	2
12		LN, 1/2"-13.....	20
13		HHCS, 7/16"-20 x 2-1/2"	4
14		PW, 7/16", Hardened	12
15		LN, 7/16"-20.....	4
16		HHCS, 1/2"-13 x 1-3/4"	4
17		HHCS, 5/8"-11 x 2"	4
18		Tie Strap, HD (Not Shown)	2
19		PW, 5/8"	8
20		LN, 5/8"-11	4
21	96110216	KIT, HDWE (Not Shown) (Includes items 9-20)	1

SNO-WAY® INTERNATIONAL, INC.



Hartford, WI 53027 USA
Website: www.snoway.com
©2020 Sno-Way® International

www.storksplows.com