

SNO-WAY®

SNOW & ICE CONTROL EQUIPMENT

ASSEMBLY & INSTALLATION INSTRUCTIONS

**SUBFRAME COMPONENTS PACKAGE
99101208**

TO FIT
2004 - LATER GMC/CHEVROLET 4500 4X2 AND 4X4

Sno-Way®, Down Pressure® and EIS® are registered trademarks of Sno-Way International, Inc.
ProControl™, MegaBlade™, V-Wing™, E-Z Switch™, Revolution™, MaxAdjust™, SpeedLock™, and QuickJack™
are trademarks of Sno-Way International, Inc.

©2014 Sno-Way® International

97101941A



1. **THINK SAFETY, ALWAYS WEAR SAFETY GLASSES WHEN PERFORMING THE OPERATIONS PRESCRIBED IN THESE INSTRUCTIONS**
2. **READ ALL INSTRUCTIONS CAREFULLY BEFORE ATTEMPTING INSTALLATION**
3. **BEFORE BEGINNING WORK MAKE SURE TO SET PARKING BRAKE AND CHOCK WHEELS**



MINIMUM VEHICLE RECOMMENDATIONS

Heavy Duty Alternator
Heavy Duty Battery

NOTE: On some vehicles it may be necessary to use a form of load booster to decrease the vehicle's front suspension sag with the snow plow in place. This can be accomplished with the use of supplementary air bags, booster springs, or similar load boosting devices. Since there are different load boosting devices available, it will up to the customer/end user to decide and purchase the product to suit the application, and not the responsibility of Sno-Way International, Inc.

ASSEMBLY TOOLS NEEDED

Impact Sockets	7/16" – 1-3/8"
Metric Sockets	10mm - 17mm
Wrenches	7/16" – 1-3/8"
Torque Wrench	
Hacksaw	
Clamping Devices ("C", Bar, type device	

INSTALLATION NOTES

1. **Unless otherwise specified, mount all Subframe Components to vehicle before tightening any hardware.**
2. **It is recommended that LOCTITE®, or similar thread locking product, be used on ALL mounting hardware (i.e. Nuts, Cap Screws, Bolts, etc.).**
3. Vehicle should be parked on a level surface with a normal vehicle load on the FRONT suspension.
4. Items in parentheses () refer to quantity required for this step. Items in parentheses with a pound sign (#) indicate the part number as found in the parts list on the last page of this document.
Example: (2) Washer, Lock, 1/2" (#10).
5. It maybe necessary to relocate license plate holder. Check state and local laws for placement, if needed.

5. Repeat the process in step #4 on the passenger side for Support Assembly RH (#5).

NOTE: On 4x2 vehicles only, Support Assemblies (#4 & #5) may need to be trimmed to obtain desired ground clearance.

6. Remove the four bolts connecting the ABS Module to the driver's side frame rail. Remove the existing bolt plate from the inside for the frame rail. Remove the two existing bolts in the bottom of the frame rail directly below the ABS Module.
7. Install Thrust Bracket Assembly LH (#6) using the two original bolts from the bottom of the frame. Replace the bolt plate, aligning with holes in the Thrust Bracket Assembly LH (#6). Replace the ABS module over the Thrust Bracket Assembly LH and secure using existing hardware.
8. Install Thrust Bracket Assembly RH (#7) by first removing the two existing bolts in the bottom of the frame rail, directly across from where the ABS Module was removed on the driver's side. Align the bottom holes on the Thrust Bracket RH (#7) with existing bolt holes and secure using existing hardware. Insert Nut Plate Assembly (#11) into the frame rail. Secure the side holes of the Thrust Bracket RH (#7) using (2) 1/2"-13 x 2 Cap Screws (#8) and (2) 1/2" Lock Washers (#10).
9. Install Mounting Assembly (#1) between the Support Assemblies (#4 and #5) using (2) 1/2"-13 x 2" Cap Screws (#8), (2) 1/2"-13 x 1-1/4" Cap screws (#12), (2) 1/2" Lock Washers (#10) and (2) 1/2" Nylock Nuts (#9) in the front set of vertical holes. In the rear set of vertical holes, secure using (4) 1/2"-13 x 2" Cap Screws (#8) and (4) 1/2" Nylock Nuts (#9), going through the Thrust Bracket Assembly, the Support Assembly and the Mounting Assembly on each side.
10. Using the Torque Specification Chart provided, Torque all Cap Screws.

MOUNTING INSTRUCTIONS

1. Remove the four bolts and nuts connecting the bumper, tow hook and leaf spring bracket to the driver side of the frame. Remove the tow hook and replace the two rear bolts and nuts.
2. Install Frame Mount Assembly LH (#2) inside of the driver side frame rail, using the remaining tow hook hardware. In the bottom, slotted hole in the Frame Mount Assembly, use existing frame hardware to secure.
3. Repeat Steps #1 and #2 on the passenger side frame rail for Frame Mount Assembly RH (#3).
4. Remove the two inner existing bolts connecting the vehicle front crossmember to the driver side frame rail. Install Support Assembly LH (#4) to Frame Mount Assembly (#2) using (2) 1/2"-13 x 2 Cap screws (#8) and (2) 1/2" Nylock Nuts (#9). Replace the original bolts previously removed from the vehicle crossmember through the Support Assembly LH (#4).

**TORQUE SPECIFICATIONS FOR
STANDARD MACHINE HARDWARE**

Bolt Size	GR.2 Dry	GR.5 Dry	GR.8 Dry	Metric Size	GR.8.8 Dry
1/4"	66*	9	12	M8	17
5/16"	11	17	25	M10	35
3/8"	20	30	45	M12	60
7/16"	32	50	70	M14	95
1/2"	50	75	110	M16	155
9/16"	70	110	150		
5/8"	100	150	220		
3/4"	175	260	380		
7/8"	170	430	600		
1"	250	640	900		

Note: These torque values are to be used for all hardware. Unless otherwise specified, all torque values must meet this specification.
 Note: All torque values are in Ft.-Lbs unless otherwise stated
Note: *In-Lbs

REMEMBER After 5 to 10 hours of snowplow usage, re-torque all Cap Screws!

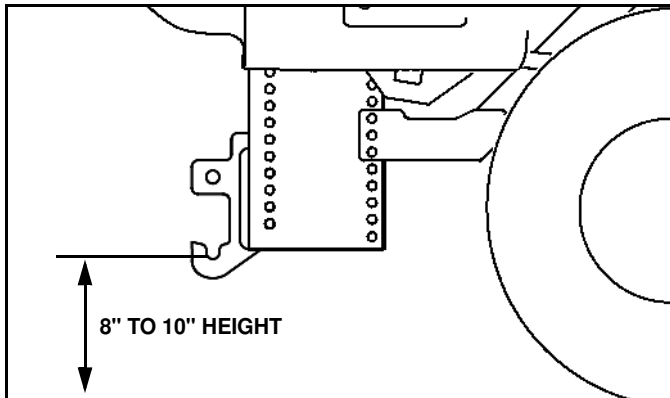

IMPORTANT: Height from the bottom of the lower pin slots on the Subframe to the ground should be between 8" and 10" for proper operation.

PARTS LIST

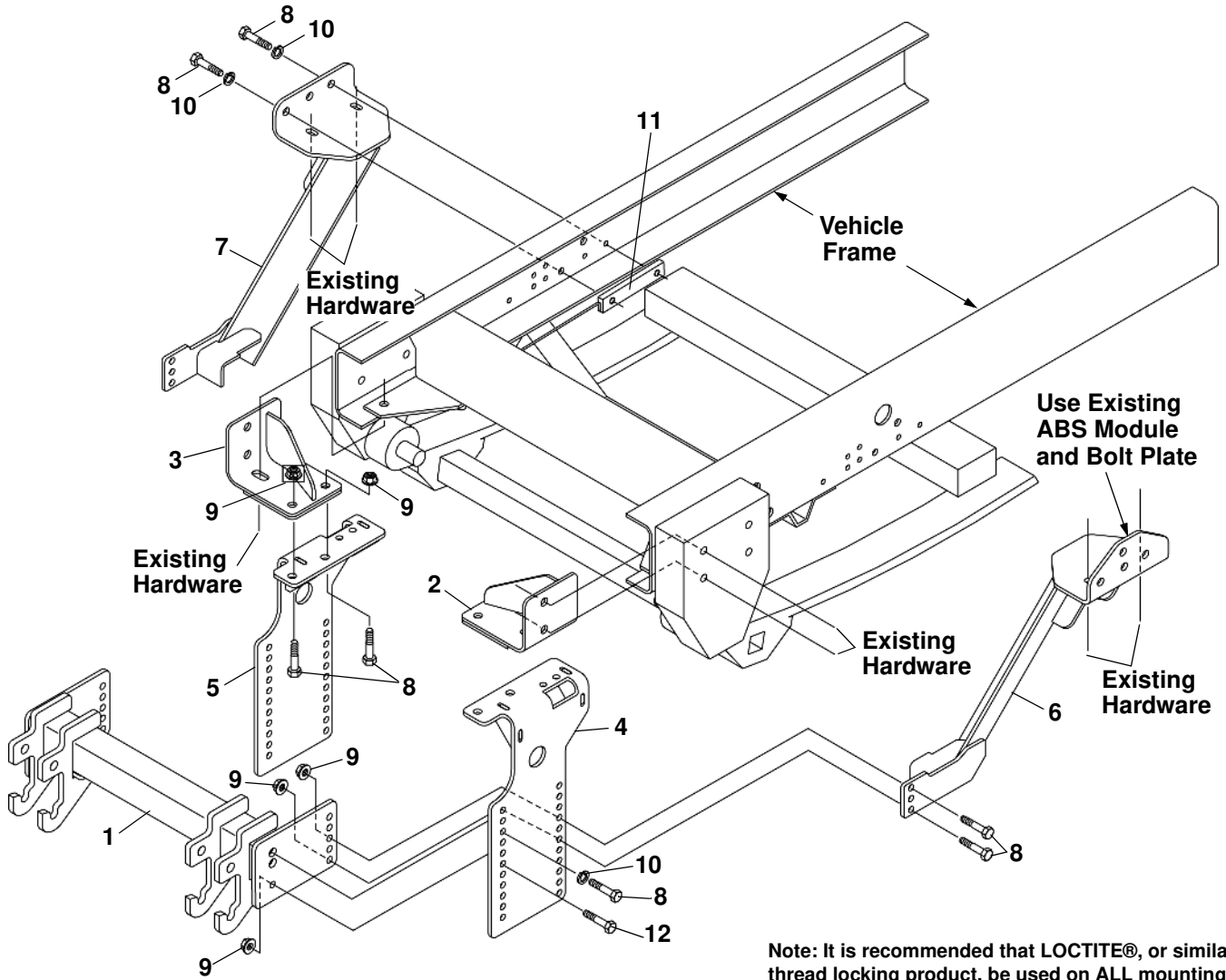

Note: It is recommended that LOCTITE®, or similar thread locking product, be used on ALL mounting hardware (i.e. Nuts, Cap Screws, Bolts, etc.).

ITEM	PART NO.	DESCRIPTION	QTY.
1		Assembly, Mounting	1
2		Assembly, Frame Mount, LH	1
3		Assembly, Frame Mount, RH.....	1
4		Assembly, Support, LH.....	1
5		Assembly, Support, RH	1
6		Assembly, Thrust Bracket, LH	1
7		Assembly, Thrust Bracket, RH.....	1
8		Cap Screw, Hex Head, 1/2"-13 x 2"	12
9		Nut, Hex, Nylock, 1/2" - 13	10
10		Washer, Lock, 1/2"	4
11		Assembly, Nut Plate	1
12		Cap Screw, Hex Head, 1/2"-13 x 1-1/4"	2
13	96115678	Kit, HDWE (Includes items 8-10 & 12)	1

SNO-WAY® INTERNATIONAL, INC.

SNO-WAY
SNOW & ICE CONTROL EQUIPMENT

Hartford, WI 53027 USA
Website: www.snoway.com
©2014 Sno-Way® International

www.storksplows.com