

# **SNO-WAY**®

**SNOW & ICE CONTROL EQUIPMENT**

## **ASSEMBLY & INSTALLATION INSTRUCTIONS**

**VEHICLE MOUNT KIT 99101209  
USING  
VEHICLE CENTER MEMBER 99100890**

**TO FIT  
2007 - LATER FORD EXPEDITION 4x4**

Sno-Way®, Down Pressure® and EIS® are registered trademarks of Sno-Way International, Inc.  
ProControl™, MegaBlade™, V-Wing™, E-Z Switch™, Revolution™, MaxAdjust™, SpeedLock™, and QuickJack™  
are trademarks of Sno-Way International, Inc.

©2015 Sno-Way® International

97101942A



1. **THINK SAFETY, ALWAYS WEAR SAFETY GLASSES WHEN PERFORMING THE OPERATIONS PRESCRIBED IN THESE INSTRUCTIONS**
2. **READ ALL INSTRUCTIONS CAREFULLY BEFORE ATTEMPTING INSTALLATION**
3. **BEFORE BEGINNING WORK MAKE SURE TO SET PARKING BRAKE AND CHOCK WHEELS**



## MINIMUM VEHICLE RECOMMENDATIONS

Heavy Duty Alternator

Heavy Duty Battery

*NOTE: On some vehicles it may be necessary to use a form of load booster to decrease the vehicle's front suspension sag with the snow plow in place. This can be accomplished with the use of supplementary air bags, booster springs, or similar load boosting devices. Since there are different load boosting devices available, it will up to the customer/end user to decide and purchase the product to suit the application, and not the responsibility of Sno-Way International, Inc.*

## ASSEMBLY TOOLS NEEDED

Impact Sockets	7/16" - 1-3/8"
	10mm - 18mm
Wrenches	7/16" - 1-3/8"
	10mm - 18mm
Torque Wrench	
Rat Tail Pry Bar	
Hacksaw	
Screwdrivers	

## INSTALLATION NOTES

1. **Unless otherwise specified, mount all Vehicle Mount Kit Components to vehicle before tightening any hardware.**
2. **It is recommended that LOCTITE®, or similar thread locking product, be used on ALL mounting hardware (i.e. Nuts, Cap Screws, Bolts, etc.).**
3. Vehicle should be parked on a level surface with a normal vehicle load on the FRONT suspension.
4. Items in parentheses ( ) refer to quantity required for this step. Items in parentheses with a pound sign (#) indicate the part number as found in the parts list on the last page of this document.  
Example: (2) Washer, Lock, 1/2" (#7).
5. It maybe necessary to relocate license plate holder. Check state and local laws for placement, if needed.

hardware to secure (hand tight only) the Side Plate and Shim Plate to the bottom of the vehicle frame. Align the 2 holes on the vertical surface of item 3 and the hole on the same horizontal lip that the tow hook bolts goes through with the holes in the frame. Insert through the front of the frame rail (3) Nut Plate Weldments (#5) and secure each separately using (1) 1/2"-13 x 1-1/2" Cap Screw (#6), (1) 1/2" Flat Washer (#7), and (1) 1/2" Lock Washer (#8).

5. Repeat Instruction #4 to install (1) Plate Side, PS (#2).
6. Attach the Vehicle Center Member (#1) to the Plate Side DS and PS (#2 and #3). Secure using (8) 1/2"-13 x 1-1/2" Cap Screws (#6), (2) 1/2" Lock Washers (#8) in the threaded holes, and (6) 1/2" Nylock Nuts (#9).
7. With all the components in place, tighten all hardware using the Torque Specification Chart provided.
8. Reinstall the bumper. Reconnect the Fog Lamp Harness Connectors if so equipped. **The bumper will have to be cut in order to accommodate the Vehicle Mount Kit height requirement.**

## MOUNTING INSTRUCTIONS

(For 2007-2014 Models)

1. Detach the rubber splash shield at the bottom edge of the bumper by removing the plastic fasteners. From the top of the bumper, remove the plastic fasteners if applicable. Remove the tow hooks from the vehicle frame and retain hardware for the Vehicle Mount Kit installation. Store the tow hooks separately for reuse if Vehicle Mount Kit is removed.
2. If equipped, remove the skid plate and save parts for reinstallation if the Vehicle Mount Kit is removed. Disconnect the fog lamp harness connectors if equipped.
3. Remove hardware that is holding the bumper onto the vehicle, once removed, remove bumper from the vehicle.
4. Install (1) Plate Side, DS (#3) and (1) Shim Plate (#4) as follows: Align the tow hook bolts in the vehicle frame with the two front slots in the horizontal lip of the Side Plate and Shim Plate. Use existing tow hook

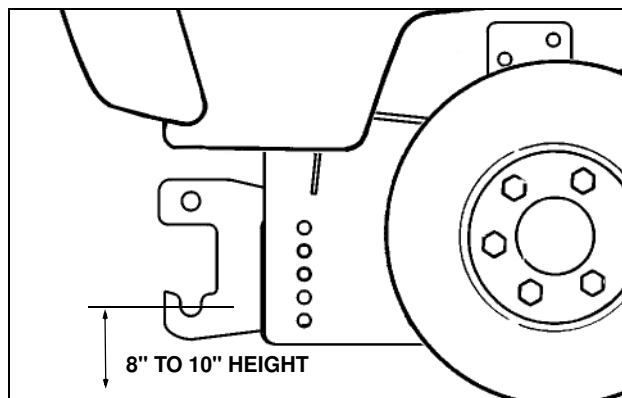

***IMPORTANT: Height from the center of the lower Plow Mounting holes on the Vehicle Mount Kit to the ground should be between 8" and 10" to ensure proper operation.***

TORQUE SPECIFICATIONS FOR STANDARD MACHINE HARDWARE					
Bolt Size	GR.2 Dry	GR.5 Dry	GR.8 Dry	Metric Size	GR.8.8 Dry
1/4"	66*	9	12	M8	17
5/16"	11	17	25	M10	35
3/8"	20	30	45	M12	60
7/16"	32	50	70	M14	95
1/2"	50	75	110	M16	155
9/16"	70	110	150		
5/8"	100	150	220		
3/4"	175	260	380		
7/8"	170	430	600		
1"	250	640	900		

These torque values are to be used for all hardware. Unless otherwise specified, all torque values must meet this specification.  
All torque values are in Ft.-Lbs unless otherwise stated  
\*In-Lbs

**REMEMBER** After 5 to 10 hours of snowplow usage, re-torque all Cap Screws!

### MOUNTING INSTRUCTIONS (For 2015 & Later Models)

1. Disconnect fog lamps if equipped. Remove hardware that is holding the bumper onto the vehicle, once removed, remove bumper from the vehicle.
2. If equipped, remove the skid plate and save parts for reinstallation if the Vehicle Mount Kit is removed. Remove tow hooks and retain hardware for Mount Kit installation.
3. Cut Shim Plates (#4) as shown and discard the small end with the single hole. (See Figure 3)

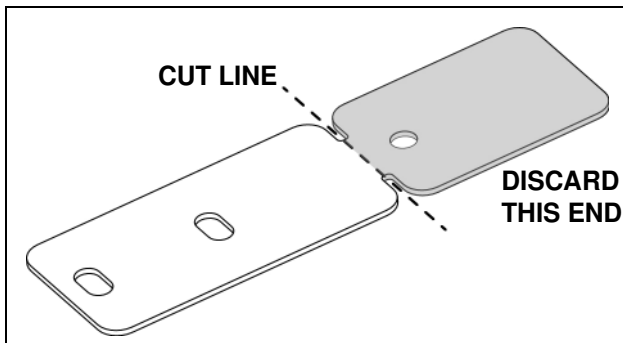

Figure 3

4. Temporarily remove the bottom intercooler bracket, by removing two fasteners (one per side). Its recommended to have the intercooler securely held in place while the bottom bracket is removed. Then remove all the hardware used in the two holes. The type of hardware found in holes may vary from shown picture. i.e Some trucks may use a bolt, rather than a stud sticking out from the frame as seen here.(See Figure 4)

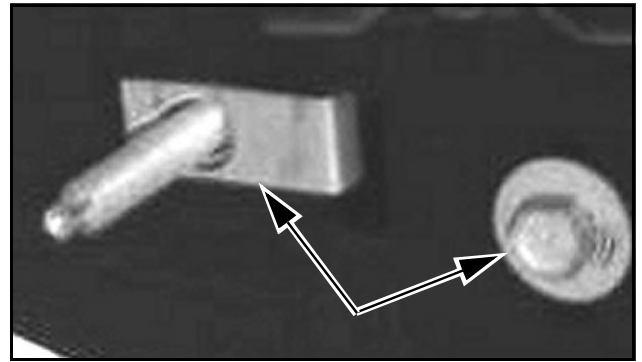

Figure 4

5. Grind the flange at the rear of the bracket away so the side weldments can sit flat against the bracket. Do this on both sides. (See Figure 5)

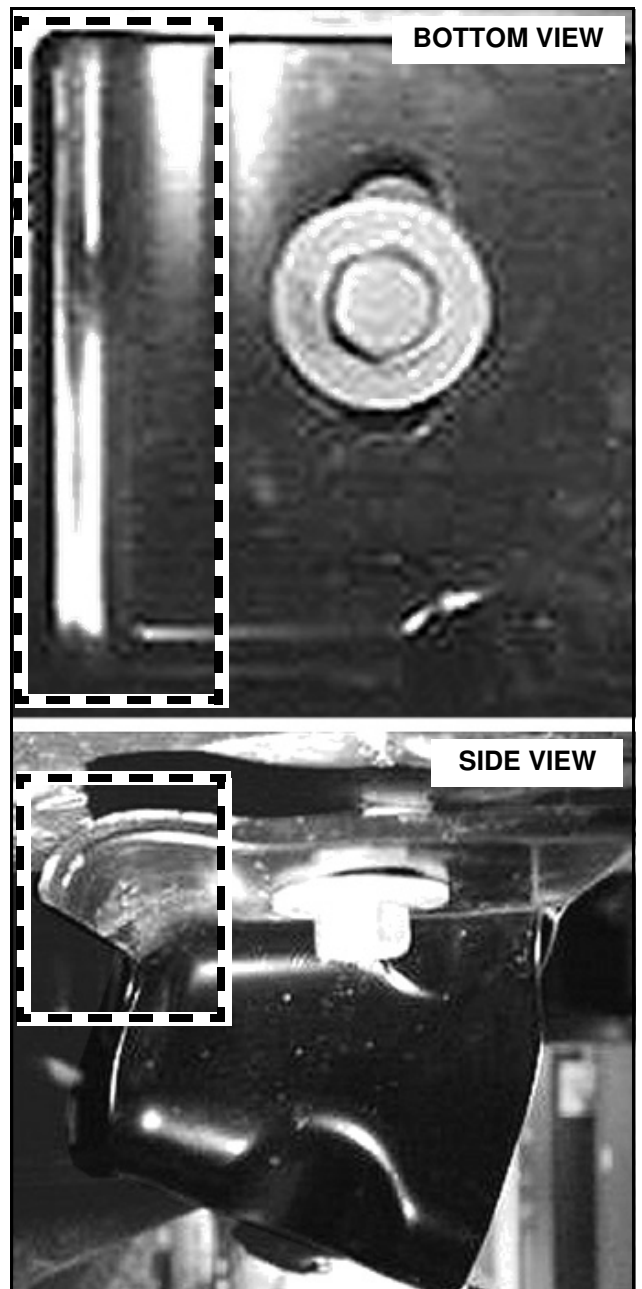

Figure 5

6. Hold the bottom intercooler bracket back to where it was before.
7. Install (1) Bracket, PS (#3) and (1) Shim Plate (#4) as follows: Align Shim Plate (#4) over the two slots on the horizontal lip of the Bracket, PS. Use existing tow hook hardware to secure (hand tight only) the Bracket, PS to the bottom of the vehicle frame.
8. Align the 2 holes on the vertical surface of item 3 with the holes in the frame. Insert through the front of the frame rail (2) Nut Plate Weldments (#4) and secure each separately using (1) 1/2"-13 x 1-1/2" Cap Screw (#5), (1) 1/2" Flat Washer (#6), and (1) 1/2" Lock Washer (#7).
9. Inset through the front of the truck frame (1) Nut Plate Weldment (#5). Insert (1) 1/2"-13 x 1-1/2" Cap Screw (#6) through (1) 1/2" Lock Washer (#7), (1) 1/2" Flat Washer (#6), rear slot of item 3, the slot in the intercooler bracket, the truck frame rail and secure with the Nut Plate Weldment (#5).
10. Repeat steps 3-9 to install (1) Bracket, DS (#2).
11. Attach the Vehicle Center Member (#1) to the Plate Side DS and PS (#2 and #3). Secure using (8) 1/2"-13 x 1-1/2" Cap Screws (#5), (2) 1/2" Lock Washers (#7) in the threaded holes, and (6) 1/2" Nylock Nuts (#8).
12. With all the components in place, tighten all hardware using the Torque Specification Chart provided.
13. Reinstall the bumper. Reconnect the Fog Lamp Harness Connectors if so equipped. **The bumper will have to be cut in order to accommodate the Vehicle Mount Kit height requirement.**

TORQUE SPECIFICATIONS FOR STANDARD MACHINE HARDWARE					
Bolt Size	GR.2 Dry	GR.5 Dry	GR.8 Dry	Metric Size	GR.8.8 Dry
1/4"	66*	9	12	M8	17
5/16"	11	17	25	M10	35
3/8"	20	30	45	M12	60
7/16"	32	50	70	M14	95
1/2"	50	75	110	M16	155
9/16"	70	110	150		
5/8"	100	150	220		
3/4"	175	260	380		
7/8"	170	430	600		
1"	250	640	900		

These torque values are to be used for all hardware. Unless otherwise specified, all torque values must meet this specification.  
All torque values are in Ft.-Lbs unless otherwise stated  
\*In-Lbs

**REMEMBER After 5 to 10 hours of snowplow usage, re-torque all Cap Screws!**

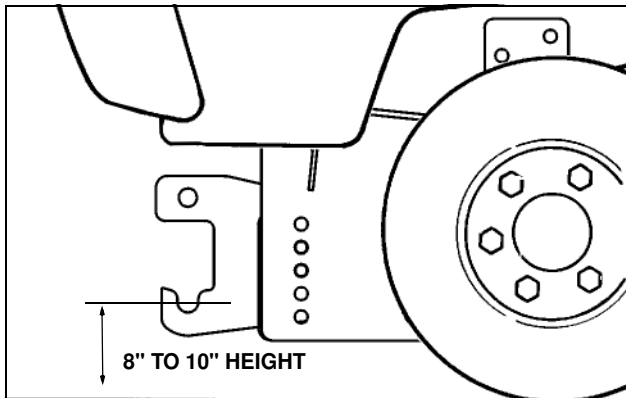

**IMPORTANT: Height from the center of the lower Plow Mounting holes on the Vehicle Mount Kit to the ground should be between 8" and 10" to ensure proper operation.**

# PARTS LIST

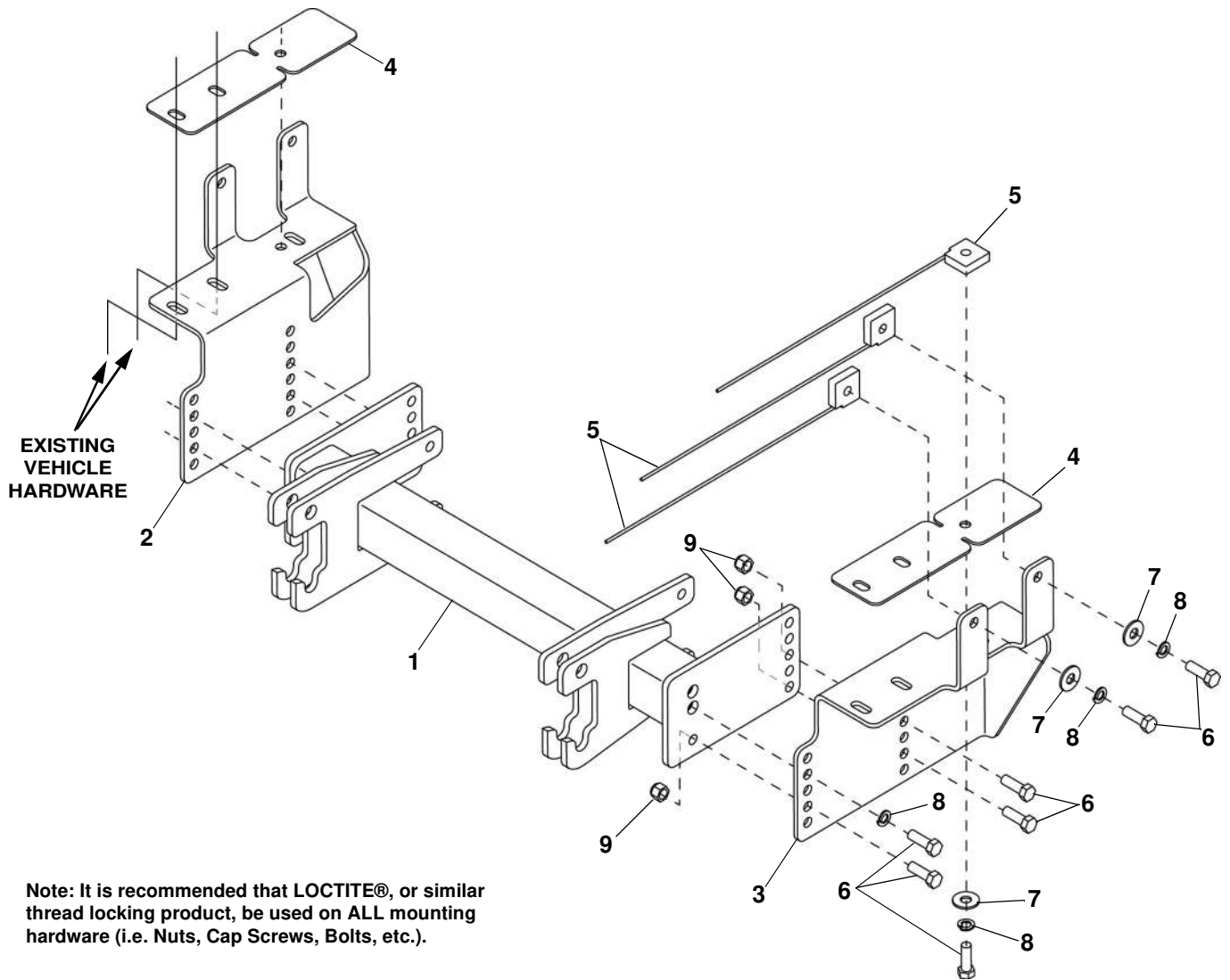

ITEM	PART NO.	DESCRIPTION	QTY.
1	99100890	Vehicle Center Member .....	1
2		Plate Side, RH .....	1
3		Plate Side, LH.....	1
4		Shim Plate .....	2
5		Nut Plate Weldment.....	6
6		Cap Screw, Hex Head, 1/2"-13 x 1-1/2" .....	14
7		Washer, Flat, 1/2".....	6
8		Washer, Lock, 1/2" .....	8
9		Nut, Nylock, 1/2" .....	6
10	96111298	Kit, HDWE (Includes items 6-9) .....	1

---

**SNO-WAY® INTERNATIONAL, INC.**



Hartford, WI 53027 USA  
Website: [www.snoway.com](http://www.snoway.com)  
©2015 Sno-Way® International