

SNO-WAY®

SNOW & ICE CONTROL EQUIPMENT

ASSEMBLY & INSTALLATION INSTRUCTIONS

**VEHICLE MOUNT KIT 99101223
FOR 26 PLOW SERIES ONLY
(Includes Vehicle Center Member)**

**TO FIT
2015 - LATER CHEVROLET COLORADO 4x4
2015 - LATER GMC CANYON 4x4**

Sno-Way®, Down Pressure® and EIS® are registered trademarks of Sno-Way International, Inc.
ProControl™, MegaBlade™, V-Wing™, E-Z Switch™, Revolution™, MaxAdjust™, SpeedLock™, and QuickJack™
are trademarks of Sno-Way International, Inc.

©2015 Sno-Way® International

97101978A



1. **THINK SAFETY, ALWAYS WEAR SAFETY GLASSES WHEN PERFORMING THE OPERATIONS PRESCRIBED IN THESE INSTRUCTIONS**
2. **READ ALL INSTRUCTIONS CAREFULLY BEFORE ATTEMPTING INSTALLATION**
3. **BEFORE BEGINNING WORK MAKE SURE TO SET PARKING BRAKE AND CHOCK WHEELS**



MINIMUM VEHICLE RECOMMENDATIONS

Heavy Duty Alternator Heavy Duty Battery

NOTE: On some vehicles it may be necessary to use a form of load booster to decrease the vehicle's front suspension sag with the snow plow in place. This can be accomplished with the use of supplementary air bags, booster springs, or similar load boosting devices. Since there are different load boosting devices available, it will up to the customer/end user to decide and purchase the product to suit the application, and not the responsibility of Sno-Way International, Inc.

ASSEMBLY TOOLS NEEDED

Impact Sockets	7/16" – 1-1/8"
Impact Sockets Metric	10mm – 19mm
Wrenches	7/16" – 1-1/8"
Drill Bits	1/4" - 17/32"
Center Punch and Hammer	
Screwdrivers	
Torque Wrench	

INSTALLATION NOTES

1. **Unless otherwise specified, mount all Subframe components to vehicle before tightening any hardware.**
2. **It is recommended that LOCTITE®, or similar thread locking product, be used on ALL mounting hardware (i.e. Nuts, Cap Screws, Bolts, etc.).**
3. Vehicle should be parked on a level surface with a normal vehicle load on the FRONT suspension.
4. Items in parentheses () refer to quantity required for this step. Items in parentheses with a pound sign (#) indicate the part number as found in the parts list on the last page of this document.
Example: (2) 1/2"-13 x 2" Cap Screws (#5).
5. It maybe necessary to relocate license plate holder. Relocate under the driver's side headlight by drilling new holes in the bumper. Check state and local laws for placement, if needed.

2. Remove the (2) screws holding the fascia to the blocker beam. (1) on each end of the blocker beam.

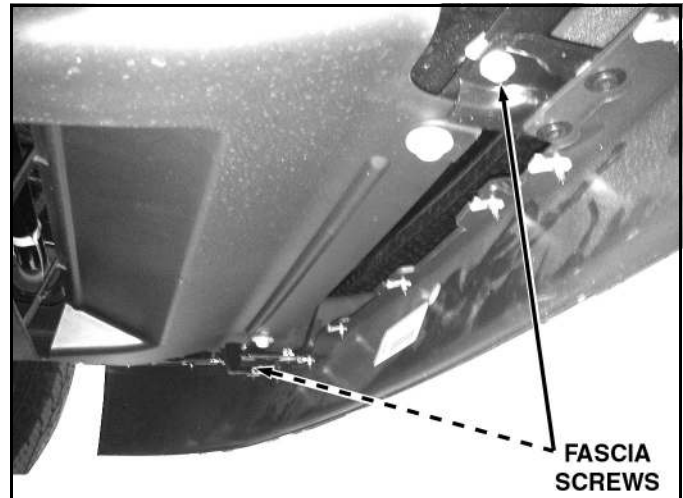

3. Remove the Lower Bumper Bracket by removing all the screws holding the Lower Bumper Bracket (Driver Side and Passenger Side) in place to the bumper and the Wheel Well Splash Shield.

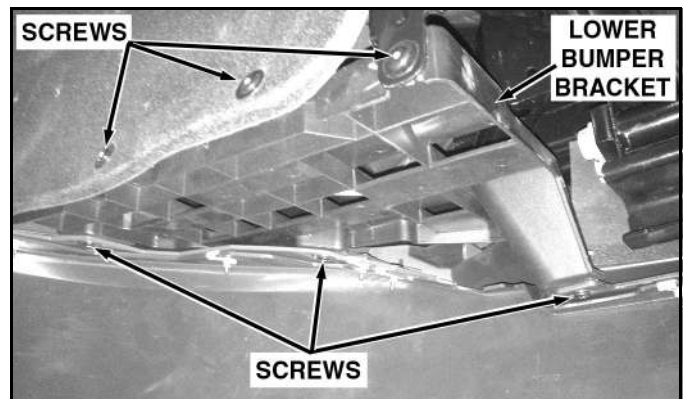

MOUNTING INSTRUCTIONS

1. It is not necessary to remove the entire bumper for this installation. Only the fascia and lower/middle portion of the bumper (seen below) will be temporarily removed. Later they will need to be modified and cut for clearance before re-installation.

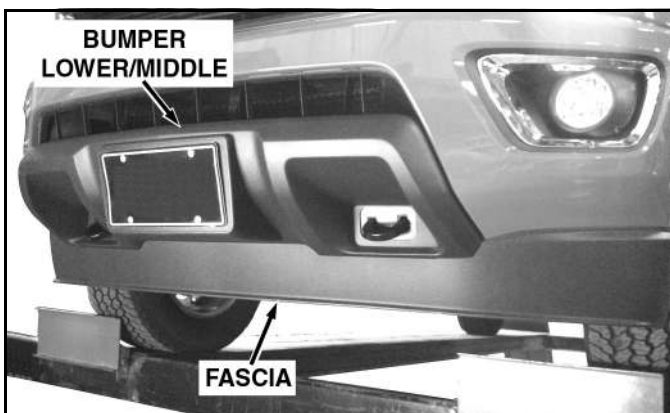

- Remove the screws that hold the fascia to the bumper. These screws can only be accessed once the Lower Bumper Bracket is removed.

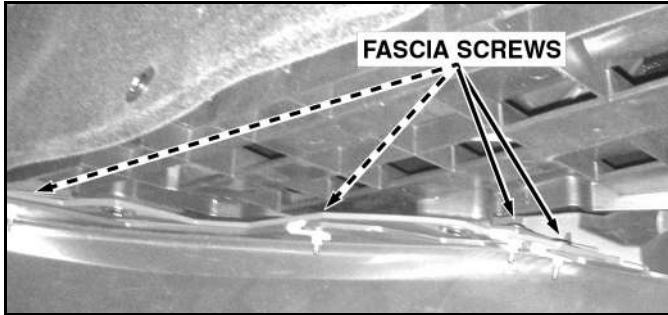

- Reach behind the bumper and unfasten (3) tabs on either side of the Lower/Middle Bumper from the Main Bumper. After reaching behind the bumper and moving the tab aside, push on the Lower/Middle Bumper near each tab to un-join the tab and slot.

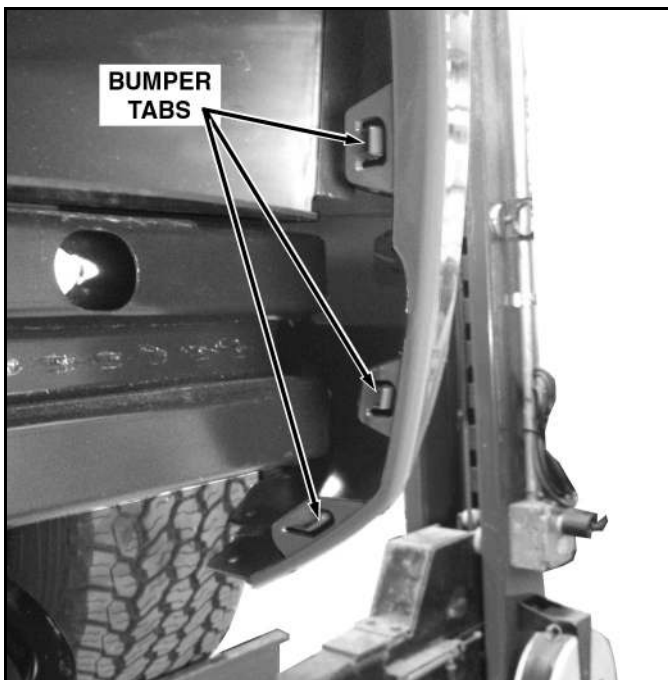

- There are similar tabs on top of the Lower/Middle Bumper that need to be un-joined. Carefully insert a small/thin flat screwdriver between the tab of the Main Bumper and the Lower/Middle Bumper (A).

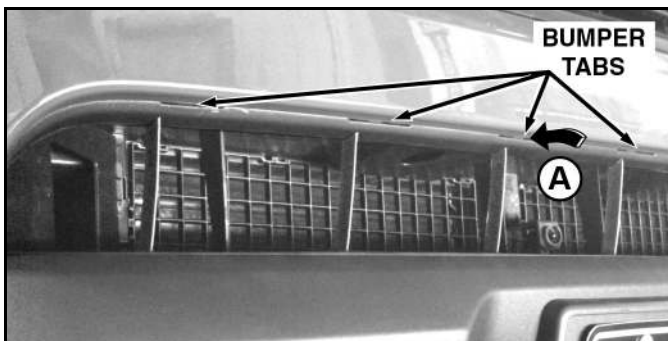

- Using the screwdriver for leverage, lift the tab (B) up. While the tab is lifted, push on the Lower/Middle Bumper near the tab toward the truck (C). Also, reach behind the Main Bumper, just above the tab and push away from the truck. Once the slot and tab are disengaged, repeat for the remaining tabs.

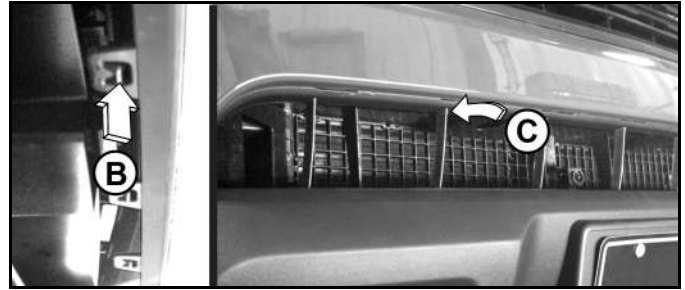

- Once the Fascia and entire Lower/Middle Bumper is loose, carefully move it downward and then out.
- Remove tow hooks if equipped. Keep for re-installation if mount is ever removed.
- Align the Driver Side Weldment (#3) over the tow hook holes located in the blocker beam. Then insert (2) 1/2"-13 x 3-1/2" Cap Screws (#6) through item #3 and the tow hook holes. This will help hold the item #3 in place.

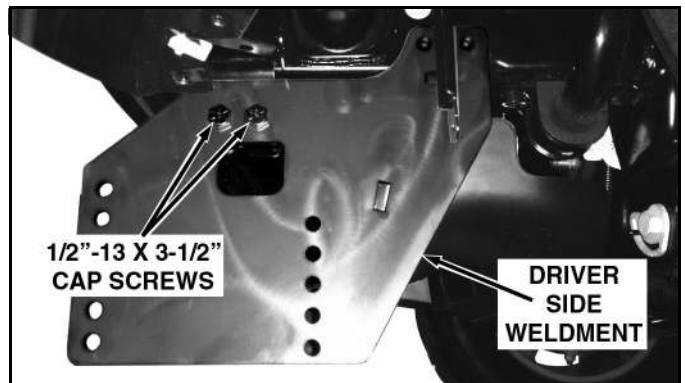

- With the Driver Side Weldment (#3) held tight against the blocker beam and the bottom of the truck frame, use the (3) holes in the rear of the Side Weldment as a template. Mark the center of the holes on the truck frame, then remove item #3 from the truck.

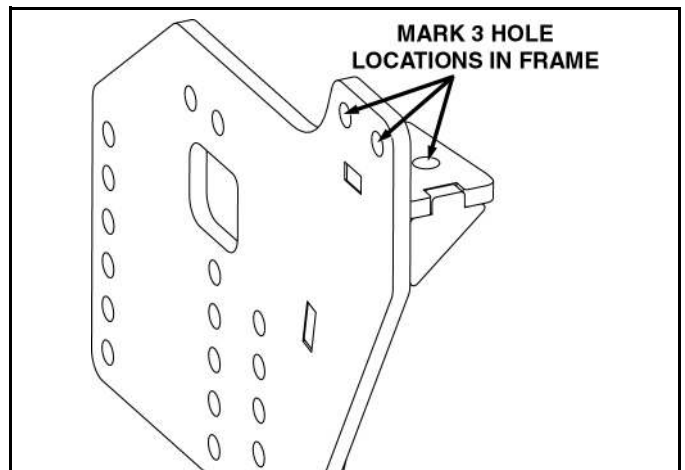

- Center punch and drill 1/4" pilot holes, then drill to 17/32". DO NOT drill through both sides of the truck frame.

13. Position the Driver Side Weldment (#3) against the frame and insert (2) 1/2"-13 x 3-1/2" Cap Screws (#6) through the Weldment and the tow hook holes. Slide (1) Clamp Plate (#4) over the (2) 1/2"-13 x 3-1/2" Cap Screws (#6). Secure loosely using (2) 1/2"-13 Nylock Nuts (#9).

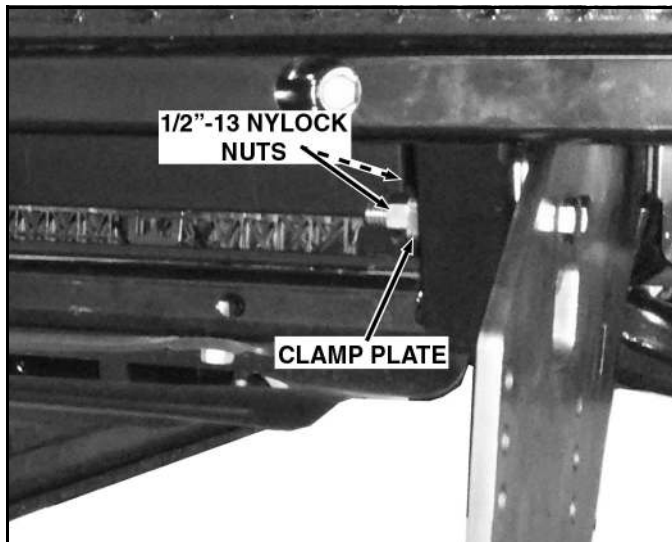

14. Repeat steps 10 through 13 for the Passenger Side Weldment (#2).

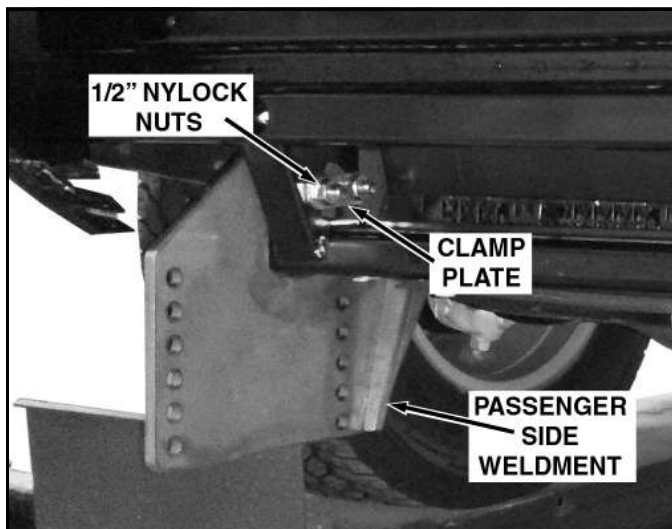

15. Temporarily loosen the Bumper Beam by removing (4) cap screws, (2) from each side.

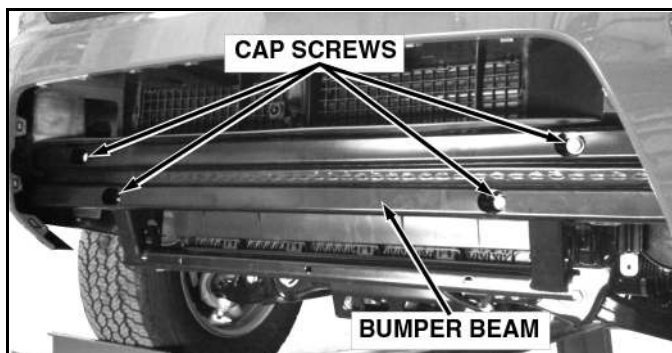

16. While items #2 & 3 are partially mounted to the truck, the Bumper Beam cannot be removed and will need to be manipulated for the following steps. Tilt the Bumper Beam at an angle to expose the hole in the side of the truck frame. The side that is lowest will be the side with the hole exposed.

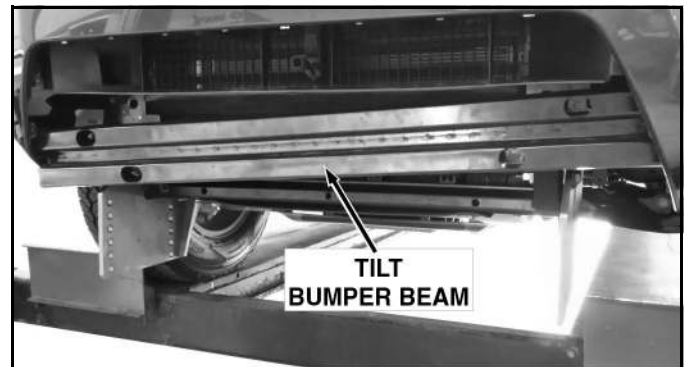

17. Insert item #10 into the Passenger Side truck frame and through the front drilled hole in the side of the truck frame, and then item #2. Secure loosely using (1) 1/2"-13 Nylock Nut (#9).



18. Twist the handle on a 1/2"-13 x 1-1/2" x 15" Handle Bolt Weldment 90°. Slip the bolt end into a 1/2" wrench and place a pliers about an inch away from the bolt and twist the handle 90°. This will make it easier to maneuver in the truck frame.

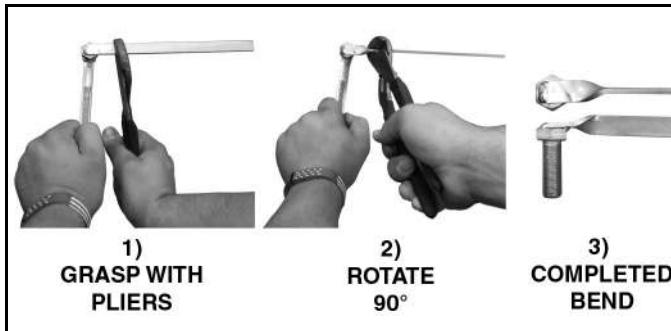

19. Place (1) 1/2" Plain Washer (#7) over the threads of the manipulated 1/2"-13 x 1-1/2" x 15" Handle Bolt Weldment (#11), from the previous step. Secure the Plain Washer against the head of the bolt using a rubber band tightly wound around the bolt up against the washer.
20. Insert items #7 & #10, from the previous step, into the Passenger Side truck frame. Insert item #10 through the bottom drilled hole in the truck frame and item #3. Secure loosely using (1) 1/2"-13 Nylock Nut (#9).
21. Insert item #10 into the Passenger Side truck frame and through the rear drilled hole, in the side of the truck frame, and then item #2. Secure loosely using (1) 1/2"-13 Nylock Nut (#9).
22. Repeat steps 16 through 21 for the Drivers Side Weldment (#3).
23. Mount the Bumper Beam back onto the truck frame that was removed in step 10.
24. Before the Lower/Middle Bumper is re-attached, it will require some modification. Locate and make vertical marks at 16-1/4 in. (D) and 16-3/4 in. (E) from the center of the bumper (F) to each side.

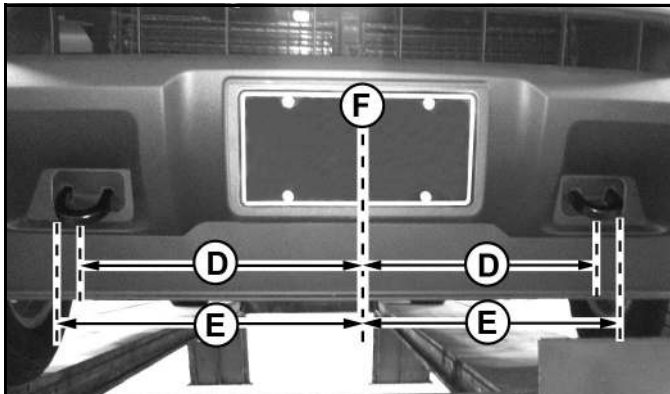

25. Cut the Fascia and Lower/Middle Bumper on the marks from the bottom up to the tow hook area.
26. Attach the Lower/Middle Bumper & fascia back onto the truck. Slip the subframe side weldments through the gaps just cut in the previous step and re-join the slots and tabs from steps 5 through 8.
27. The amount of further cutting in the bumper will vary depending upon the vehicle suspension height and where in the 8-10in. range the Vehicle Center Member (#1) is placed.

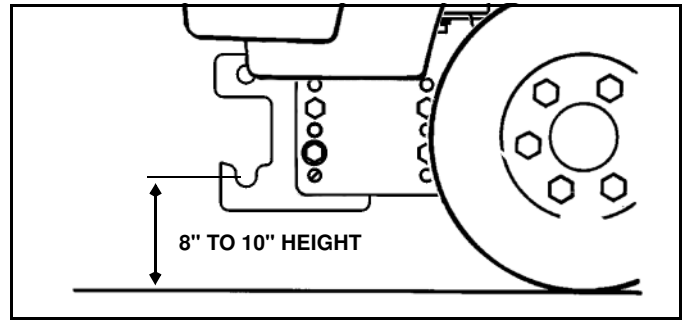

IMPORTANT: Height from the center of the lower Plow mounting holes on the Subframe to the ground should be between 8" and 10" to insure proper operation.

28. A minimum section of 1/2" wide by 2" must be removed to fit the VCM in the lowest position. Remove the sections shown below.

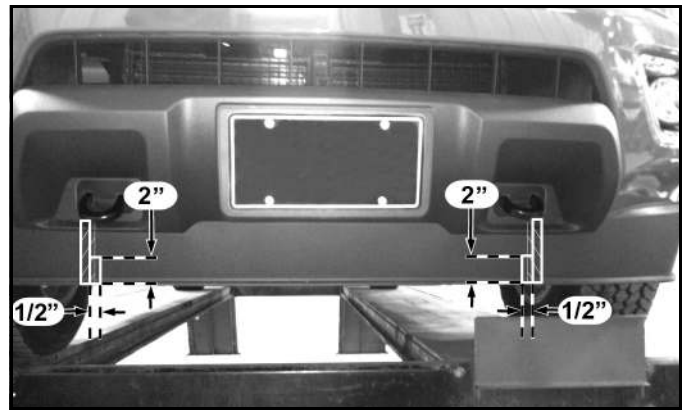

29. In the steps that follow, the Vehicle Center Member (#1) will be temporarily, then permanently installed. The hardware used for installation will depend where the bolts are used in the VCM (See figure below).
- Five holes on each side of the VCM are drilled, and cap screws used in those holes for mounting to either side weldment must be secured with nylock nuts.
 - Two holes on each side of the VCM have weld nuts installed, and require a lockwasher be used with the cap screw when these holes are used.

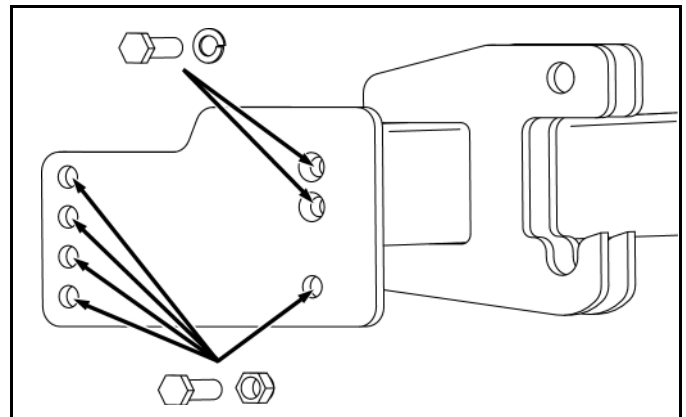

30. Temporarily mount the Vehicle Center Member (#1) in the lowest position using (2) 1/2"-13 x 1-3/4" Cap Screws (#5), (1) 1/2" Lock Washers (#8) and (1) 1/2"-13 Nylock Nuts (#9) on each side of item #1.

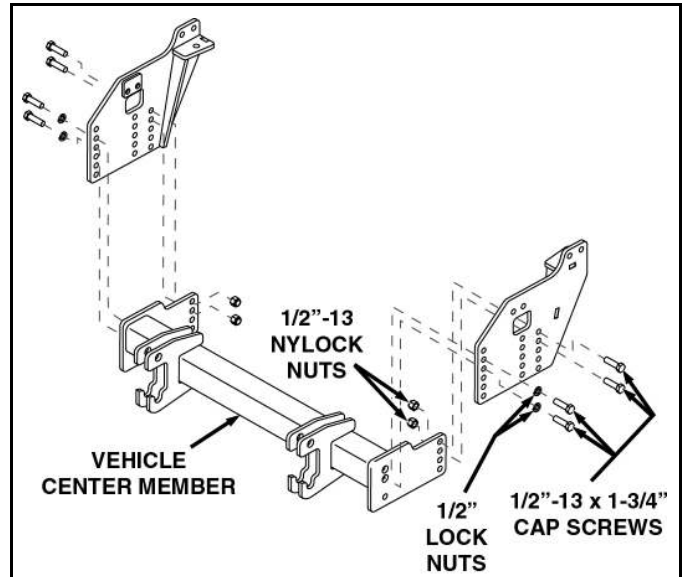
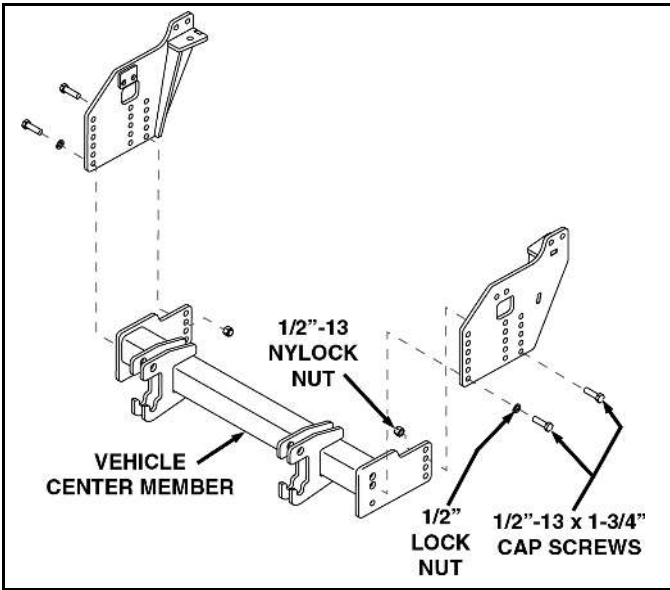

- 31. Measure the height of the VCM lower mounting hole to the ground. Determine where the Vehicle Center Mount (#1) must be mounted to reach the 8-10 inch range.
- 32. Once the Location is determined, use the VCM as a template to determine where the Bumper and Fascia must be cut to mount the VCM in its proper location. Remove the VCM.
- 33. The most cutting will be needed if placed in the highest position to reach the 8-10 in. range. The picture below illustrates what areas of the bumper would need to be cut to clear the VCM and the Lower Lightbar of the plow.

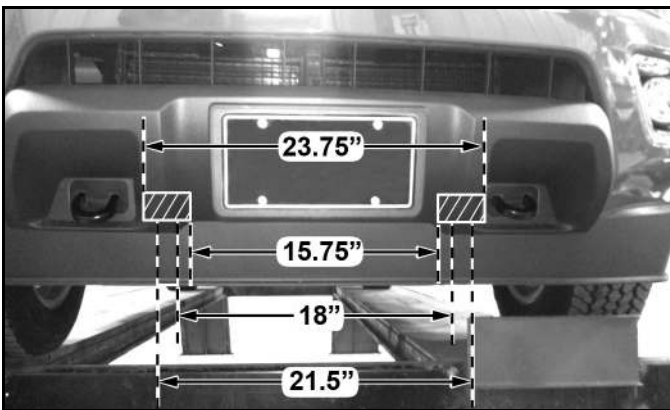

34. Once the bumper has been modified to fit, attach the Vehicle Center Member (#1) to the Driver & Passenger Side Weldments (#2 & 3). Secure using (8) 1/2"-13 x 1-3/4" Cap Screws (#5), (4) 1/2" Lock Washers (#8) and (4) 1/2"-13 Nylock Nuts (#9).

- 35. With all the components now in place, tighten all the hardware. Using the Torque Specification Chart at the end of these instructions, torque all Cap Screws.
- 36. Re-attach the remaining parts of the bumper to the truck that were removed or loosened in steps 1 through 4.

TORQUE SPECIFICATIONS FOR STANDARD MACHINE HARDWARE					
Bolt Size	GR.2 Dry	GR.5 Dry	GR.8 Dry	Metric Size	GR.8.8 Dry
1/4"	66*	9	12	M8	17
5/16"	11	17	25	M10	35
3/8"	20	30	45	M12	60
7/16"	32	50	70	M14	95
1/2"	50	75	110	M16	155
9/16"	70	110	150		
5/8"	100	150	220		
3/4"	175	260	380		
7/8"	170	430	600		
1"	250	640	900		

These torque values are to be used for all hardware. Unless otherwise specified, all torque values must meet this specification.
All torque values are in Ft.-Lbs unless otherwise stated
*In-Lbs

REMEMBER After 5 to 10 hours of snowplow usage, re-torque all Cap Screws!

PARTS LIST

Note: It is recommended that LOCTITE®, or similar thread locking product, be used on ALL mounting hardware (i.e. Nuts, Cap Screws, Bolts, etc.).

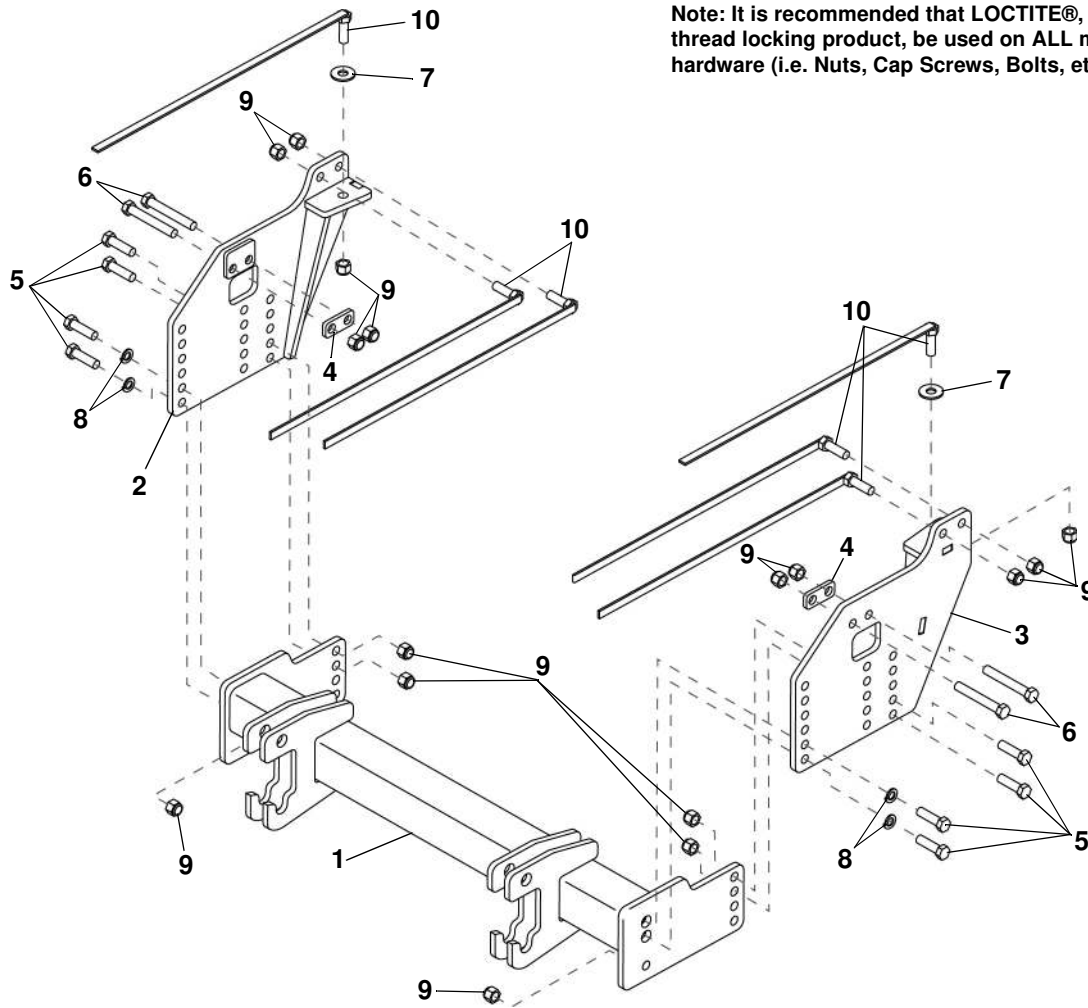

ITEM	PART NO.	DESCRIPTION	QTY.
1		Vehicle Center Member	1
2		Passenger Side Weldment	1
3		Driver Side Weldment.....	1
4		Clamp Plate	2
5		Cap Screw, Hex Head, 1/2"-13 x 1-3/4"	8
6		Cap Screw, Hex Head, 1/2"-13 x 3-1/2"	4
7		Plain Washer, 1/2"	2
8		Washer, Lock, 1/2"	4
9		Nut, Nylock, 1/2"-13	14
10		Handle Bolt Weldment, 1/2"-13 x 1-1/2" x 15"	6
11	96115430	Kit, Hardware (Includes items 4-10)	1

SNO-WAY® INTERNATIONAL, INC.



Hartford, WI 53027 USA
Website: www.snoway.com
©2015 Sno-Way® International