

SNO-WAY®

SNOW & ICE CONTROL EQUIPMENT

ASSEMBLY & INSTALLATION INSTRUCTIONS

**VEHICLE MOUNT KIT 99101243
FOR UTV SERIES PLOW**

TO FIT
2015 & Later - Kawasaki Mule Pro



©2015 Sno-Way® International

97101987A



1. THINK SAFETY, ALWAYS WEAR SAFETY GLASSES WHEN PERFORMING THE OPERATIONS PRESCRIBED IN THESE INSTRUCTIONS
2. READ ALL INSTRUCTIONS CAREFULLY BEFORE ATTEMPTING INSTALLATION
3. BEFORE BEGINNING WORK MAKE SURE TO SET PARKING BRAKE AND CHOCK WHEELS



ASSEMBLY TOOLS NEEDED

Drill Bits	1/4" - 17/32"
Impact Sockets	7/16" - 1-3/8"
Wrenches	7/16" - 1-3/8"
Torque Wrench	
Rat Tail Pry Bar	
Center Punch and Hammer	
C-Clamp	

INSTALLATION NOTES

1. Vehicle should be parked on a level surface with a normal vehicle load on the FRONT suspension.
2. On some vehicles it may be necessary to raise or stiffen the suspension to decrease the vehicles front suspension sag with the snow plow in place.
3. Unless otherwise specified, mount all Vehicle Mount Kit Components to vehicle before tightening any hardware.
4. It is recommended that LOCTITE®, or similar thread locking product, be used on ALL mounting hardware (i.e. Nuts, Cap Screws, Bolts, etc.).
5. Items in parentheses () refer to quantity required for this step. Items in parentheses with a pound sign (#) indicate the part number as found in the parts list on the last page of this document.
Example: (2) 1/2" Lock Washers (#9).

MOUNTING INSTRUCTIONS

1. Insert Top Weldment (#4) between the brush guard and UTV frame. Align the six mount holes in the Top Weldment (#4) with the six holes in the UTV frame.

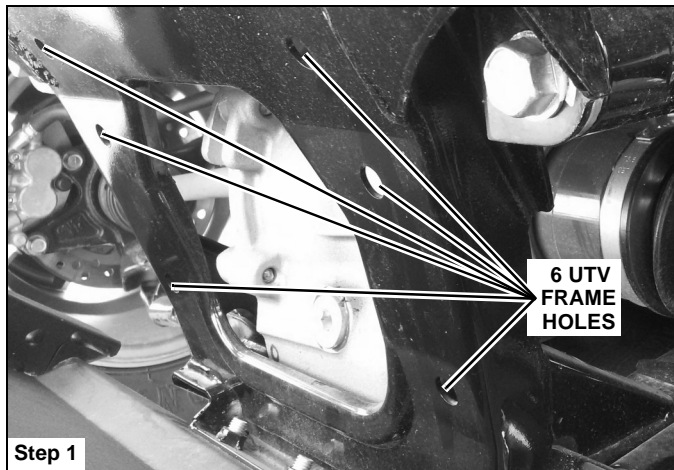

2. Insert (4) 7/16"-14 x 1" Hex Head Cap Screws (#6) through the top four holes of the Top Weldment (#4) and then the UTV frame. Then, loosely secure (4) 7/16" Plain Washers (#7) and (4) 7/16"-14 Lock Nuts (#8).
3. Insert (2) 7/16"-14 x 1" Hex Head Cap Screws (#6) through the bottom two holes in the UTV frame and then the Top Weldment (#4). Then, loosely secure (2) 7/16"-14 Lock Nuts (#8).
4. Clamp the Top Weldment (#4) in position so the tabs with the lower four holes are tight against the UTV frame and the front of the Top Weldment is tight against the brush guard. While the Top Weldment (#4) is held in position, on the brush guard, mark the center of the four holes of the Top Weldment (#4) contacting the brush guard. Remove clamps.

5. Remove the brush guard by removing the two bolts on top (one on each side) and the three at the bottom center of the brush guard.

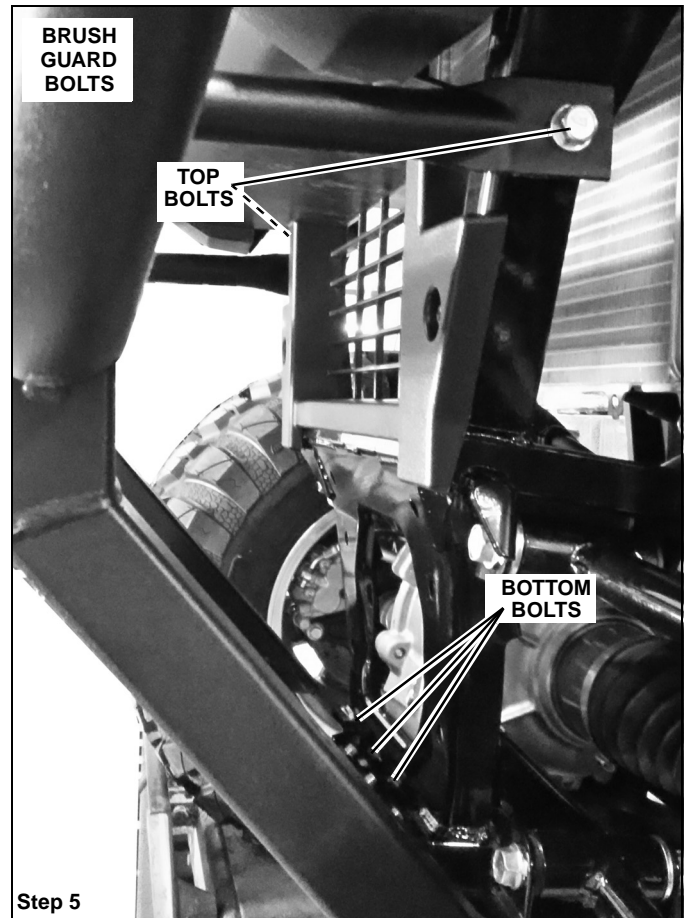

6. Center punch and drill a 1/4" pilot hole, then drill to 1/2" at the marked locations from step 4. Remove any burrs.

7. Mount the brush guard back onto the UTV, but only loosely attach the top two bolts that were removed from step 5.
8. Align the Bottom Weldment (#5) over top of the brush guard, with the three holes that mounted the brush guard and two holes under the UTV frame.

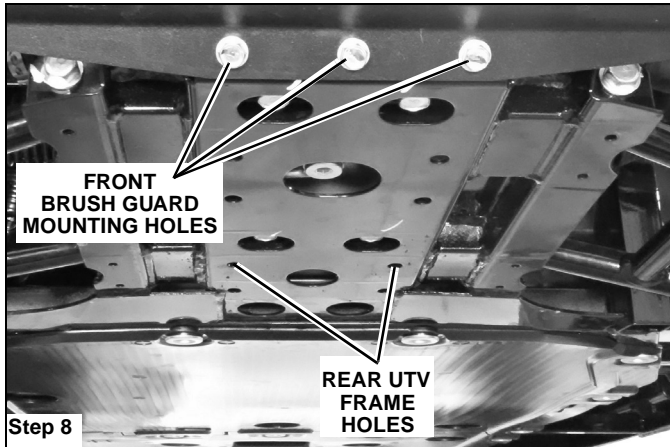

9. Insert (3) M8-1.25 x 25mm Hex Head Cap Screws (#12) through (3) 5/16" Lock Washers (#13) & (3) 5/16" Plain Washers (#14). Then, loosely secure the screws into the Bottom Weldment (#5), brush guard, and the UTV frame.
10. Insert (2) 3/8"-16 x 1" Hex Head Cap Screws (#11) through the rear two holes of the Bottom Weldment (#5) and UTV frame. Then, loosely secure (2) 3/8"-16 Lock Nuts (#11) to the (2) 3/8"-16 x 1" Hex Head Cap Screws (#11).
11. Align the set of two holes in the Front Bracket, DS (#2) to the holes in the driver side of the Top Weldment (#4) and brush guard. Insert (2) 3/8"-16 x 1-1/4" Hex Head Cap Screws (#9) through Front Bracket, DS (#2), brush guard, and Top Weldment (#4). Loosely secure with (2) 3/8"-16 Lock Nuts (#11).
12. Repeat step 11 for attaching the Front Bracket, PS (#3)
13. Align the UTV Mount (#1) with the holes in the front brackets (#2 & 3). Adjust the UTV Mount (#1) so that the center of the bottom slot is 11-12 off the ground.

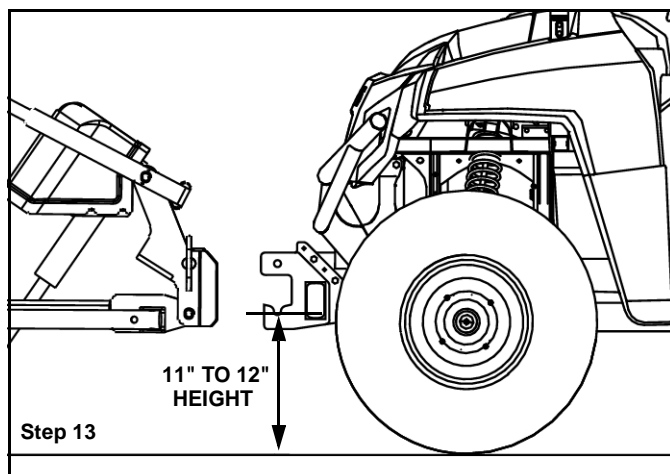

IMPORTANT: Height from the bottom of the lower pin slots on the UTV Mount to the ground should be between 11" and 12" to ensure proper operation.

14. Loosely secure the UTV Mount (#1) with (6) 3/8"-16 x 1-1/4" Hex Head Cap Screws (#9) and (6) 3/8"-16 Lock Nuts (#11).
 - a. Two of the screws (one on each side) should go through the UTV Mount (#1), the bottom hole of the Front Bracket (#2 or 3), and Bottom Weldment (#5).
 - b. Two of the screws (one on each side) should go in the highest aligned hole between the UTV Mount and Front Brackets.
 - c. The last remaining two screws can go between the top and bottom mounted screws.

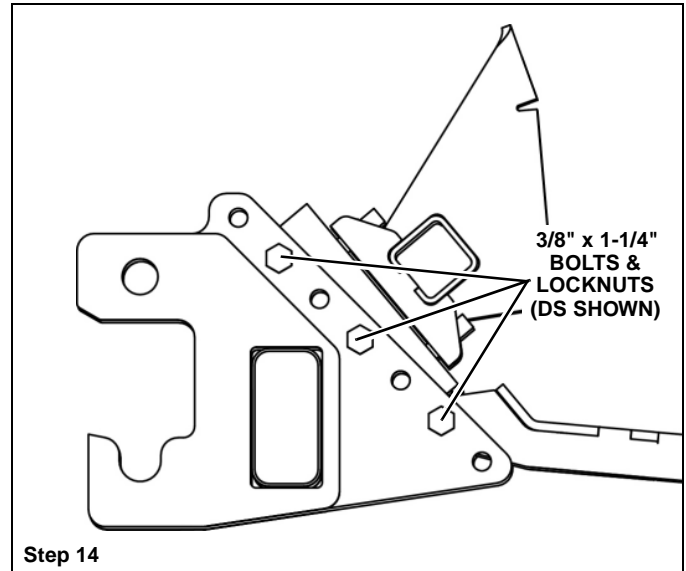

15. Tighten all hardware using the Torque Specification Chart below.
 - a. Begin with the M8 hardware and screws holding the brush guard.
 - b. Next, the hardware holding the Top and Bottom Weldments (#4 & 5) to the UTV frame.
 - c. Lastly, the remaining hardware attached to the Front Brackets (#2 & 3)

TORQUE SPECIFICATIONS FOR STANDARD MACHINE HARDWARE					
Bolt Size	GR.2 Dry	GR.5 Dry	GR.8 Dry	Metric Size	GR.8.8 Dry
1/4"	66*	9	12	M8	17
5/16"	11	17	25	M10	35
3/8"	20	30	45	M12	60
7/16"	32	50	70	M14	95
1/2"	50	75	110	M16	155
9/16"	70	110	150		
5/8"	100	150	220		
3/4"	175	260	380		
7/8"	170	430	600		
1"	250	640	900		

These torque values are to be used for all hardware. Unless otherwise specified, all torque values must meet this specification.
All torque values are in Ft.-Lbs unless otherwise stated
*In-Lbs

REMEMBER After 5 to 10 hours of snowplow usage, re-torque all hardware!

PARTS LIST

Note: It is recommended that LOCTITE®, or similar thread locking product, be used on ALL mounting hardware (i.e. Nuts, Cap Screws, Bolts, etc.).

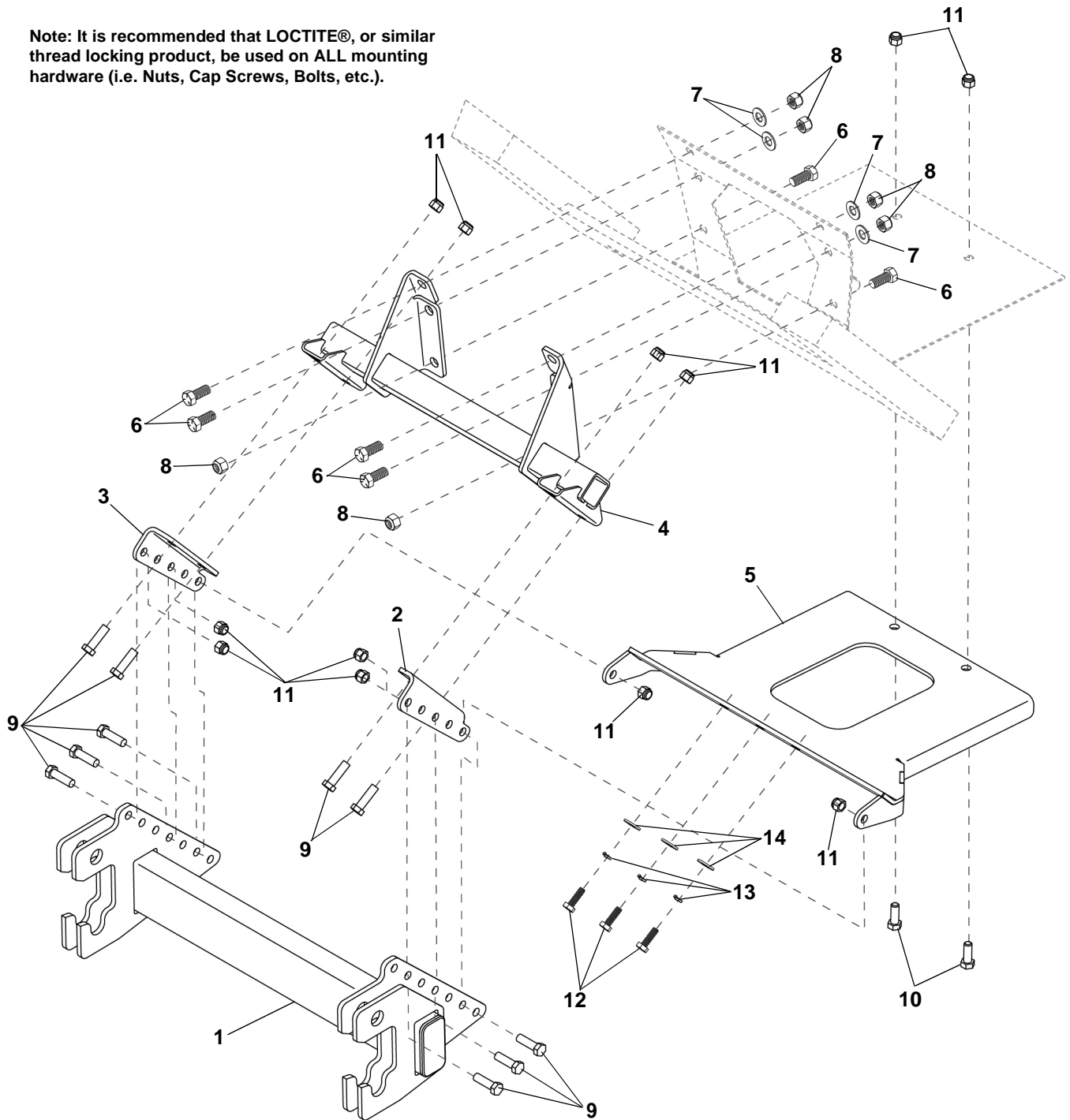

PARTS LIST

ITEM	PART NO.	DESCRIPTION	QTY.
1		UTV Mount	1
2		Bracket, Front, DS	1
3		Bracket, Front, PS	1
4		Weldment, Top.....	1
5		Weldment, Bottom.....	1
6		HHCS, 7/16"-14 x 1"	6
7		PW, 7/16".....	4
8		LN, 7/16"-14	6
9		HHCS, 3/8"-16 x 1-1/4".....	10
10		HHCS, 3/8"-16 x 1"	2
11		LN, 3/8"-16	12
12		HHCS, M8-1.25 x 25	3
13		LW, 5/16"	3
14		PW, 5/16".....	3
15	96116035	Kit, HDWE (Not Shown) (Includes Items 6-14).....	1

SNO-WAY® INTERNATIONAL, INC.



Hartford, WI 53027 USA
Website: www.snoway.com
©2015 Sno-Way® International

www.storksplows.com