

SNO-WAY®

SNOW & ICE CONTROL EQUIPMENT

ASSEMBLY & INSTALLATION INSTRUCTIONS

**VEHICLE MOUNT KIT 99101244
FOR UTV SERIES PLOW**

TO FIT

2013 & Later - Yamaha Viking
2017 & Later - Yanmar Bull, Longhorn



©2016 Sno-Way® International

97101994A



1. THINK SAFETY, ALWAYS WEAR SAFETY GLASSES WHEN PERFORMING THE OPERATIONS PRESCRIBED IN THESE INSTRUCTIONS
2. READ ALL INSTRUCTIONS CAREFULLY BEFORE ATTEMPTING INSTALLATION
3. BEFORE BEGINNING WORK MAKE SURE TO SET PARKING BRAKE AND CHOCK WHEELS



ASSEMBLY TOOLS NEEDED

Impact Sockets	7/16" - 1-3/8"
Wrenches	7/16" - 1-3/8"
Torque Wrench	

INSTALLATION NOTES

1. Vehicle should be parked on a level surface with a normal vehicle load on the FRONT suspension.
2. On some vehicles it may be necessary to raise or stiffen the suspension to decrease the vehicles front suspension sag with the snow plow in place.
3. Unless otherwise specified, mount all Vehicle Mount Kit Components to vehicle before tightening any hardware.
4. It is recommended that LOCTITE®, or similar thread locking product, be used on ALL mounting hardware (i.e. Nuts, Cap Screws, Bolts, etc.).
5. Items in parentheses () refer to quantity required for this step. Items in parentheses with a pound sign (#) indicate the part number as found in the parts list on the last page of this document.
Example: (2) 1/2" Lock Washers (#9).

MOUNTING INSTRUCTIONS

1. Remove the skid plate by removing the (4) screws holding it in place.

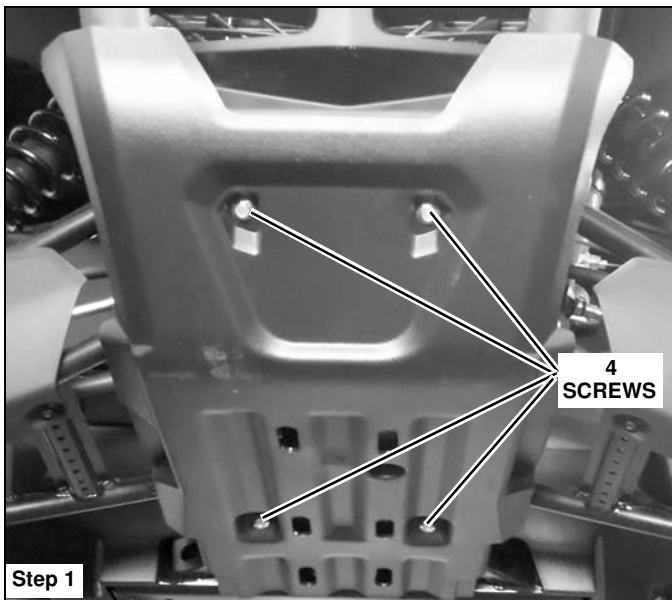

2. Temporarily remove the brush guard by removing the (6) screws hold it in place.

3. Place the Mounting Weldment (#2) on the UTV frame by aligning the four rear holes of the Mounting Weldment (#2) with the four holes in the UTV frame.

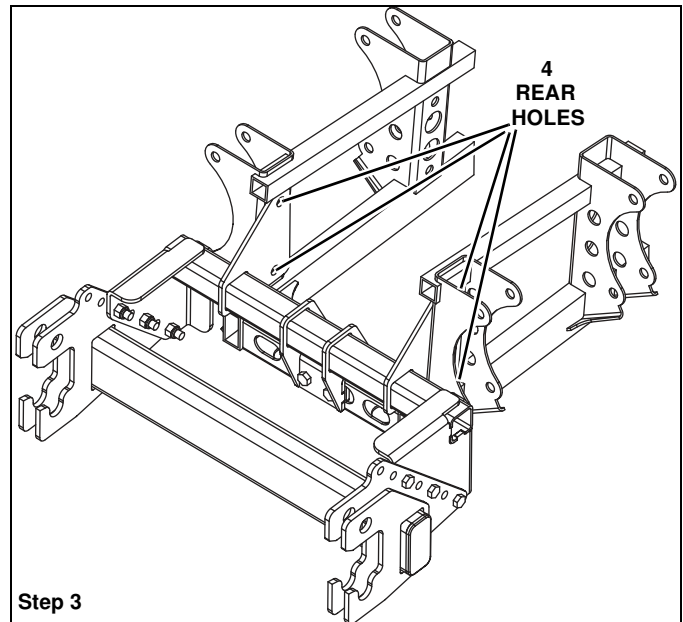

4. In those four holes from step 3, Insert (4) 7/16"-14 x 1" Hex Head Cap Screws (#4) and loosely secure with (4) 7/16"-14 Lock Nuts (#5).

- Slide the Mount Bracket (#3) in the UTV frame and align the four holes in the bracket with the four bottom holes in the Mounting Weldment (#2). Once aligned, insert (4) 3/8"-16 x 1" Hex Head Cap Screws (#6) through the Mounting Weldment (#2), UTV frame, and Mount Bracket (#3). Loosely secure with (4) 3/8"-16 Lock Nuts (#8).

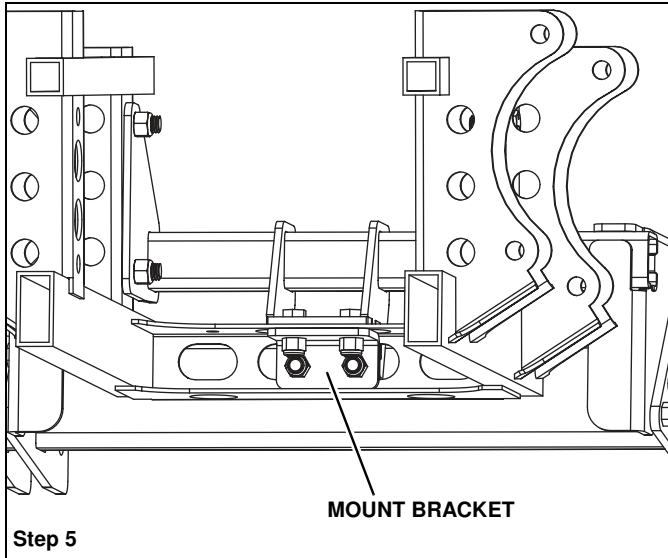

- Tighten all installed hardware.
- Re-install the brush guard.
- Align the UTV Mount (#1) with the holes in the Mounting Weldment (#2). Adjust the UTV Mount (#1) so that the center of the bottom slot is 11-12" off the ground.

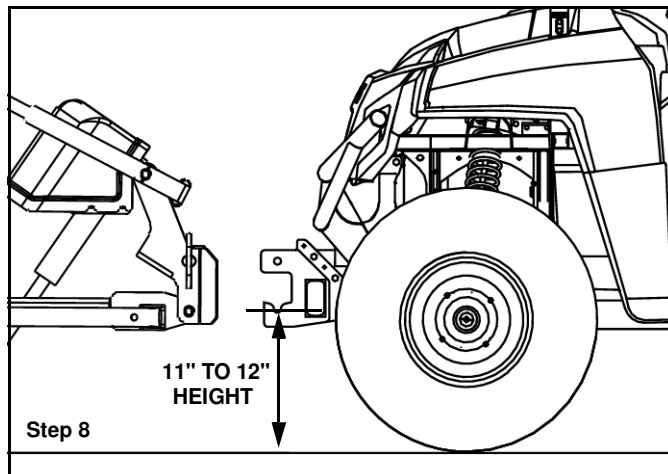

IMPORTANT: Height from the bottom of the lower pin slots on the UTV Mount to the ground should be between 11" and 12" to ensure proper operation.

- Loosely secure the UTV Mount (#1) with (6) 3/8"-16 x 1-1/4" Hex Head Cap Screws (#7) and (6) 3/8"-16 Lock Nuts (#8).
- Tighten all hardware using the Torque Specification Chart below.

TORQUE SPECIFICATIONS FOR STANDARD MACHINE HARDWARE					
Bolt Size	GR.2 Dry	GR.5 Dry	GR.8 Dry	Metric Size	GR.8.8 Dry
1/4"	66*	9	12	M8	17
5/16"	11	17	25	M10	35
3/8"	20	30	45	M12	60
7/16"	32	50	70	M14	95
1/2"	50	75	110	M16	155
9/16"	70	110	150		
5/8"	100	150	220		
3/4"	175	260	380		
7/8"	170	430	600		
1"	250	640	900		

These torque values are to be used for all hardware. Unless otherwise specified, all torque values must meet this specification.
All torque values are in Ft.-Lbs unless otherwise stated
*In-Lbs

REMEMBER After 5 to 10 hours of snowplow usage, re-torque all hardware!

- It's recommended the skid plate be modified to fit around the vehicle mount kit. If not, retain it with the hardware for re-installation if the mount is removed.

PARTS LIST

Note: It is recommended that LOCTITE®, or similar thread locking product, be used on ALL mounting hardware (i.e. Nuts, Cap Screws, Bolts, etc.).

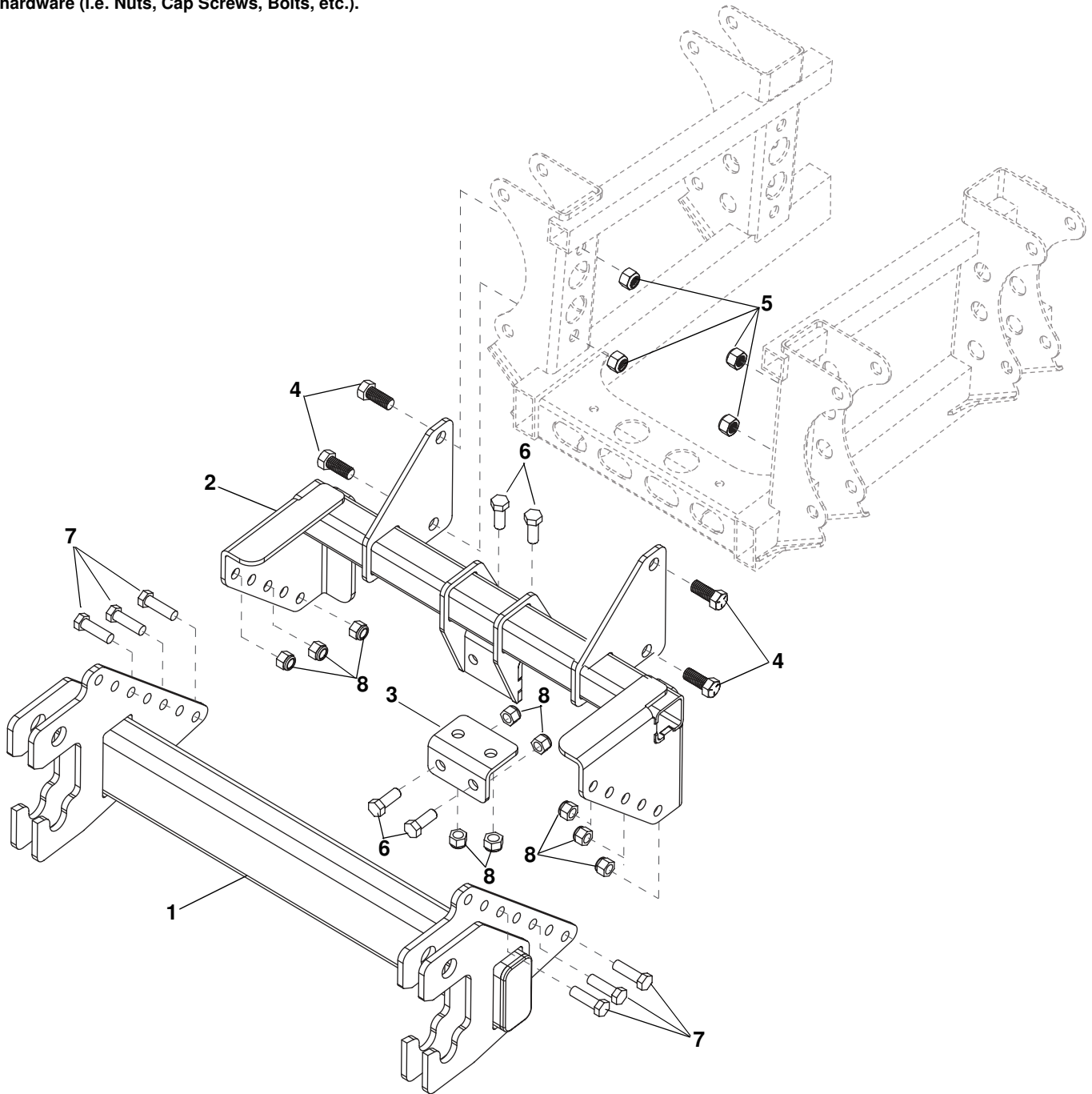

PARTS LIST

ITEM	PART NO.	DESCRIPTION	QTY.
1		UTV Mount	1
2		Weldment, Mounting.....	1
3		Bracket, Mount	1
4		HHCS, 7/16"-14 x 1"	4
5		LN, 7/16"-14	4
6		HHCS, 3/8"-16 x 1"	4
7		HHCS, 3/8"-16 x 1-1/4"	6
8		LN, 3/8"-16	10
9	96116046	Kit, HDWE (Not Shown) (Includes Items 3-8).....	1

SNO-WAY® INTERNATIONAL, INC.



Hartford, WI 53027 USA
Website: www.snoway.com
©2016 Sno-Way® International

www.storksplows.com