

# **SNO-WAY**®

**SNOW & ICE CONTROL EQUIPMENT**

## **ASSEMBLY & INSTALLATION INSTRUCTIONS**

**VEHICLE MOUNT KIT 99101277  
FOR UTV SERIES PLOW**

TO FIT  
2015 & Later - Cub Cadet Challenger



©2017 Sno-Way® International

97102081A



**1. THINK SAFETY, ALWAYS WEAR SAFETY GLASSES WHEN PERFORMING THE OPERATIONS PRESCRIBED IN THESE INSTRUCTIONS**



**2. READ ALL INSTRUCTIONS CAREFULLY BEFORE ATTEMPTING INSTALLATION**

**3. BEFORE BEGINNING WORK MAKE SURE TO SET PARKING BRAKE AND CHOCK**

## ASSEMBLY TOOLS

Impact Sockets	7/16" - 1-3/8"
Impact Sockets	5 mm - 16 mm
Wrenches	7/16" - 1-3/8"
Wrenches	5 mm - 16 mm
Torque Wrench	
Cutting Wheel	

## INSTALLATION NOTES

1. Vehicle should be parked on a level surface with a normal vehicle load on the FRONT suspension.
2. On some vehicles it may be necessary to raise or stiffen the suspension to decrease the vehicles front suspension sag with the snow plow in place.
3. Unless otherwise specified, mount all Vehicle Mount Kit Components to vehicle before tightening any hardware.
4. It is recommended that LOCTITE®, or similar thread locking product, be used on ALL mounting hardware (i.e. Nuts, Cap Screws, Bolts, etc.).
5. Items in parentheses () refer to quantity required for this step. Items in parentheses with a pound sign (#) indicate the part number as found in the parts list on the last page of this document.  
Example: (2) 1/2" Lock Washers (#9).

## MOUNTING INSTRUCTIONS

1. Remove the top two screws in the skid plate.  
(See Figure 1.)

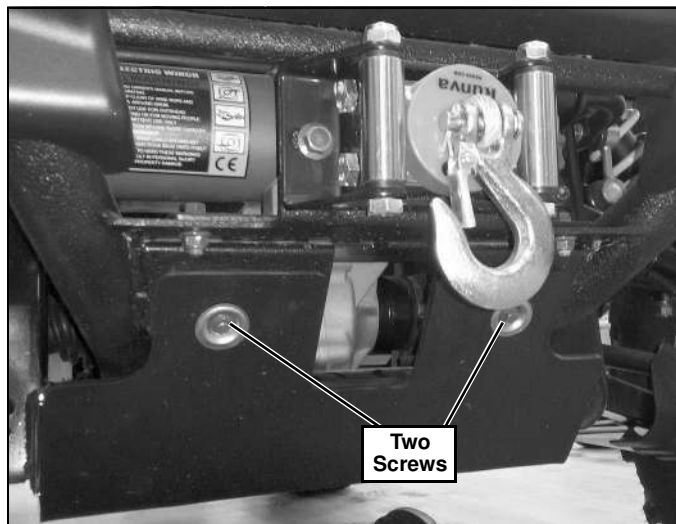

Figure 1

2. Mark a line completely across the skid plate, 1/2" from the edge to the specified holes. Then, cut and remove the front portion of the skid plate. This will allow the mount to seat flush against the frame. (See Figure 2.)

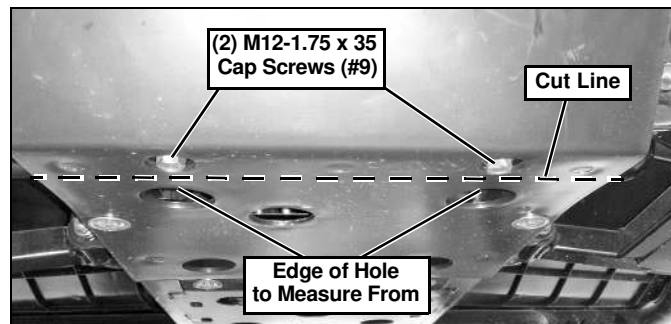

Figure 2

3. Remove the two lower M12-1.75 x 35 Cap Screws (#9) seen above. Keep for re-installation in a later step.  
(See Figure 2.)

4. If vehicle is equipped with a winch, remove the hardware holding in the fairlead bracket and the front end of the winch to the frame. (See Figure 3.)

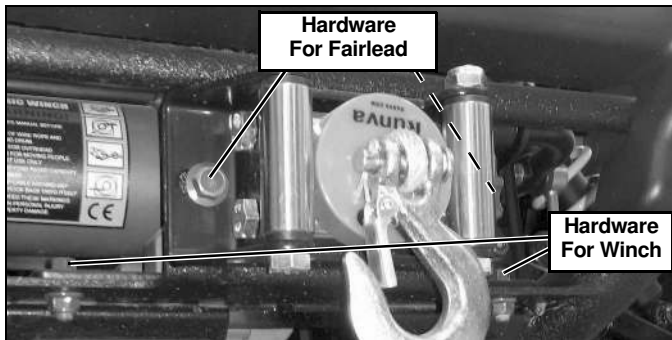

Figure 3

5. Place the Mounting Weldment (#2) against the frame and line up all holes. If equipped with a winch, also slide the top end of the Mounting Weldment (#2) behind the fairlead. (See Figure 4.)

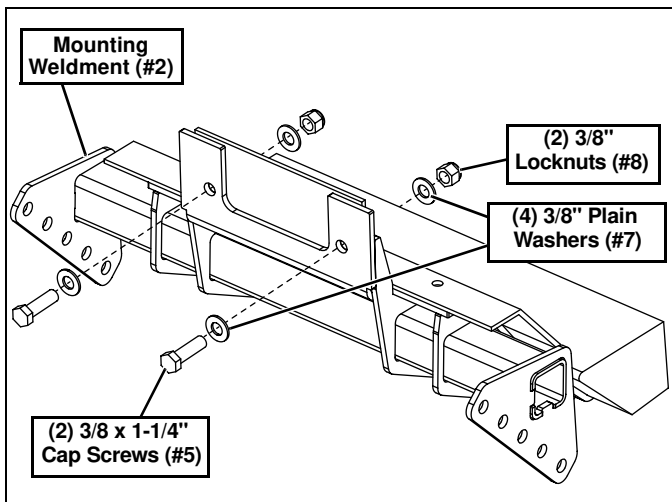

Figure 4

6. Insert (2) 3/8"-16 x 1-1/4" Cap Screws (#5) through (2) 3/8" Plain Washers (#7), the top holes of the Mounting Weldment (#2), and into the vehicle frame. Insert the hardware through the Fairlead first if equipped with a winch. Then, secure with (2) 3/8" Plain Washers (#7) and (2) 3/8"-16 Locknuts (#8). (See Figure 4.)

7. Secure the two remaining top holes in the frame and item #2 with (2) 5/16-18 x 1" Cap Screws (#3) and (2) 5/16"-18 Locknuts (#4). (See Figure 5.)

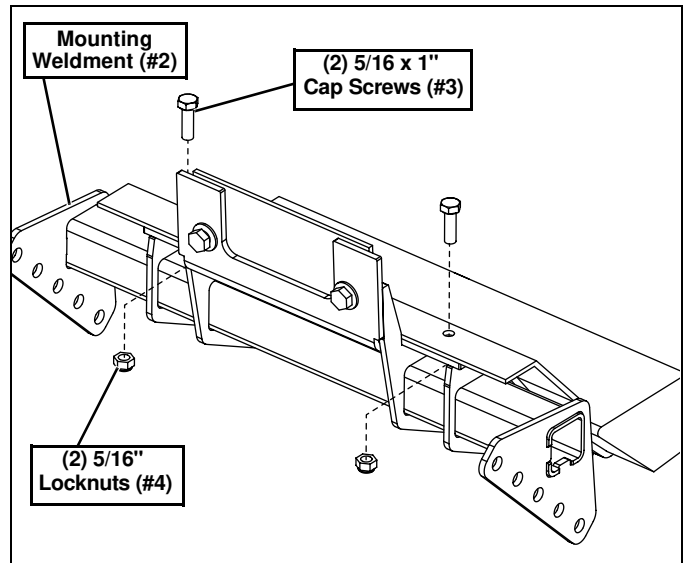

Figure 5

8. Place the M12-1.75 x 35 Cap Screws (#9) that were removed in step 3 back into position, but insert through the Mounting Weldment (#2) first. (See Figure 6.)

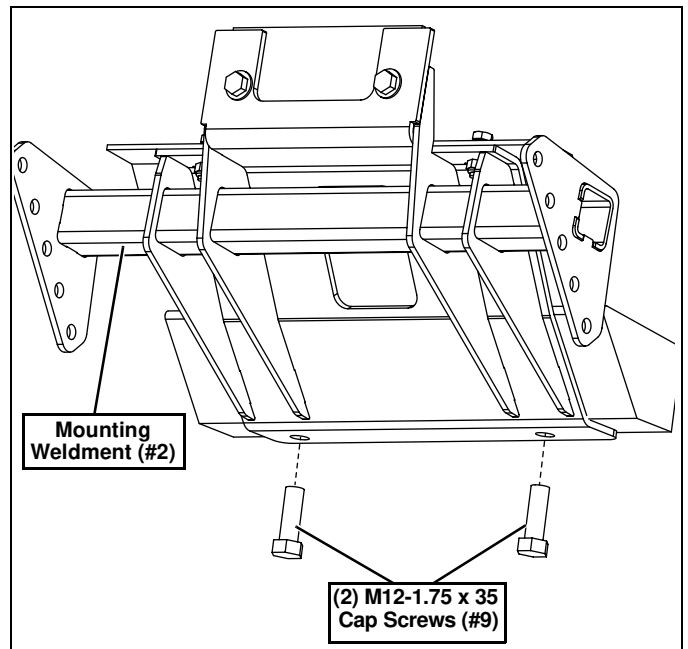

Figure 6

9. Align the UTV Mount (#1) with the holes in the Mounting Weldment (#2). Adjust the UTV Mount (#1) so that the center of the bottom slot is 11-12" off of the ground. (See Figure 7.)

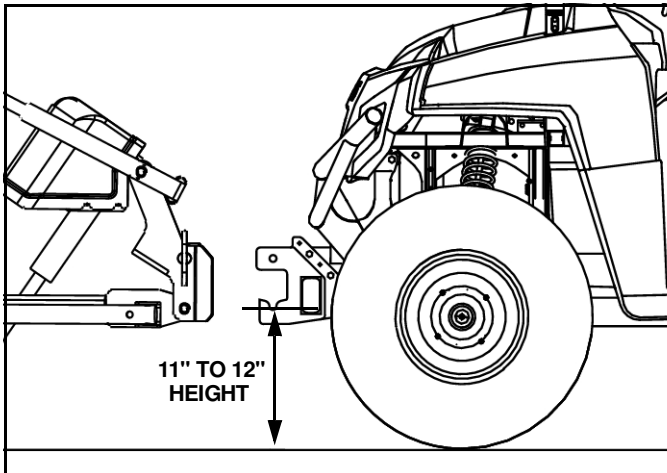

Figure 7

10. Attach the UTV Mount (#1) to the Mounting Weldment (#2) with (6) 3/8"-16 x 1" Cap Screws (#6) and (6) 3/8"-16 Locknuts (#8). Three on each side. (See Figure 8.)

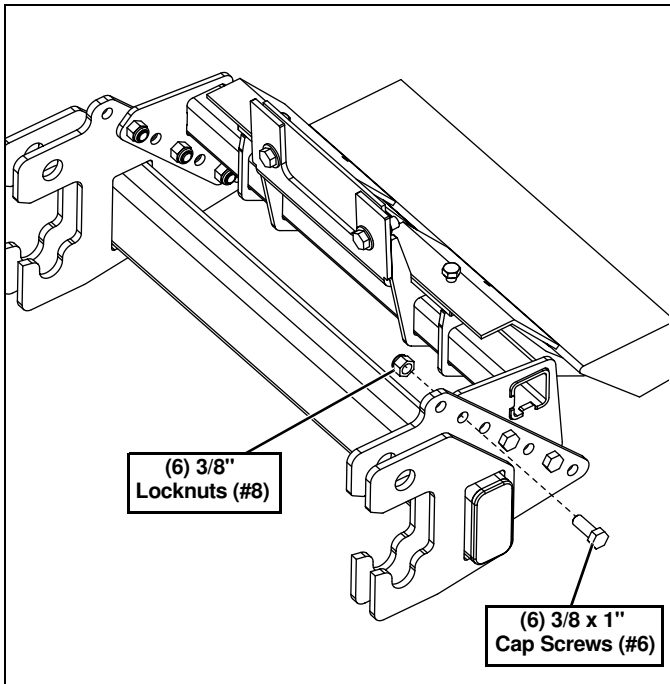

Figure 8

11. Tighten all the hardware using the Torque Specification Chart below.

TORQUE SPECIFICATIONS FOR STANDARD MACHINE HARDWARE					
Bolt Size	GR.2 Dry	GR.5 Dry	GR.8 Dry	Metric Size	GR.8.8 Dry
1/4"	66*	9	12	M8	17
5/16"	11	17	25	M10	35
3/8"	20	30	45	M12	60
7/16"	32	50	70	M14	95
1/2"	50	75	110	M16	155
9/16"	70	110	150		
5/8"	100	150	220		
3/4"	175	260	380		
7/8"	170	430	600		
1"	250	640	900		

These torque values are to be used for all hardware. Unless otherwise specified, all torque values must meet this specification. All torque values are in Ft.-Lbs unless otherwise stated  
\*In-Lbs

**REMEMBER After 5 to 10 hours of snowplow usage, re-torque all hardware!**

# PARTS LIST

Note: It is recommended that LOCTITE®, or similar thread locking product, be used on ALL mounting hardware (i.e. Nuts, Cap Screws, Bolts, etc.).

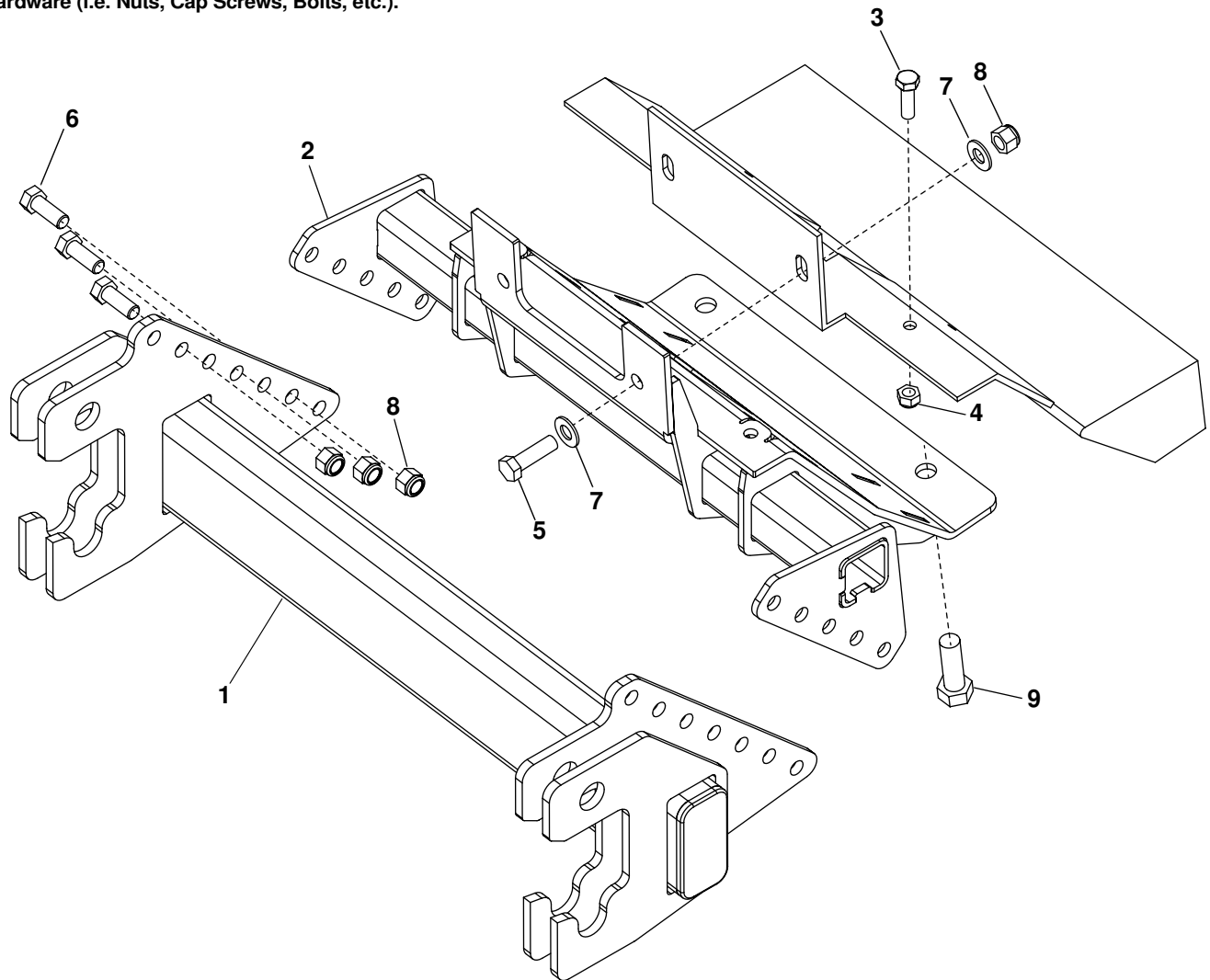

ITEM	PART NO.	DESCRIPTION	QTY.
1		UTV Mount.....	1
2		Weldment, Mounting.....	1
3		HHCS, 5/16"-18 x 1 .....	2
4		LN, 5/16"-18.....	2
5		HHCS, 3/8"-16 x 1-1/4".....	2
6		HHCS, 3/8"-16 x 1" .....	6
7		PW, 3/8".....	4
8		LN, 3/8"-16.....	8
9		HHCS, M12-1.75 x 35mm (Existing Hardware).....	2
10	96116395	Kit, HDWE (Not Shown) (Includes Items 3-8).....	1

# NOTES

# NOTES

---

**SNO-WAY® INTERNATIONAL, INC.**



Hartford, WI 53027 USA  
Website: [www.snoway.com](http://www.snoway.com)  
©2017 Sno-Way® International

[www.storksplows.com](http://www.storksplows.com)