

# **SNO-WAY**®

**SNOW & ICE CONTROL EQUIPMENT**

## **ASSEMBLY & INSTALLATION INSTRUCTIONS**

**VEHICLE MOUNT KIT 99101280**

TO FIT:  
2012 & LATER John Deere RSX

©2017 Sno-Way® International

97102108A



1. THINK SAFETY, ALWAYS WEAR SAFETY GLASSES WHEN PERFORMING THE OPERATIONS PRESCRIBED IN THESE INSTRUCTIONS
2. READ ALL INSTRUCTIONS CAREFULLY BEFORE ATTEMPTING INSTALLATION
3. BEFORE BEGINNING WORK MAKE SURE TO SET PARKING BRAKE AND CHOCK WHEELS



## ASSEMBLY TOOLS NEEDED

Drill Bits	1/4" - 17/32"
Impact Sockets	7/16" - 3/4"
Wrenches	7/16" - 3/4"
Torque Wrench	
Rat Tail Pry Bar	
Center Punch and Hammer	
Screwdrivers	

## INSTALLATION NOTES

1. Vehicle should be parked on a level surface with a normal vehicle load on the FRONT suspension.
2. On some vehicles it may be necessary to raise or stiffen the suspension to decrease the vehicles front suspension sag with the snow plow in place.
3. Unless otherwise specified, mount all Vehicle Mount Kit Components to vehicle before tightening any hardware.
4. It is recommended that LOCTITE®, or similar thread locking product, be used on ALL mounting hardware (i.e. Nuts, Cap Screws, Bolts, etc.).

Items in parentheses ( ) refer to quantity required for this step. Items in parentheses with a pound sign (#) indicate the part number as found in the parts list on the last page of this document.

Example: (2) 1/2" Lock Washers (#9).

## MOUNTING INSTRUCTIONS

*NOTE: If any other options are installed, like front receiver, winch, etc. they may need to be removed before installing this kit.*

1. If you have the Optional Pivoting Brush Guard begin on Step 7:
  - The Optional Pivoting Brush Guard pivots forward to allow access to the hood.
  - The Standard Brush Guard is bolted solid to the frame.
2. For the Standard Brush Guard (on the driver's side), remove the (2) M12x30 Cap Screws securing the Brush Guard Bracket to the frame. Also remove the front M10x35 Cap Screw holding the Brush Guard Bracket to the frame. (See Figure 1.)

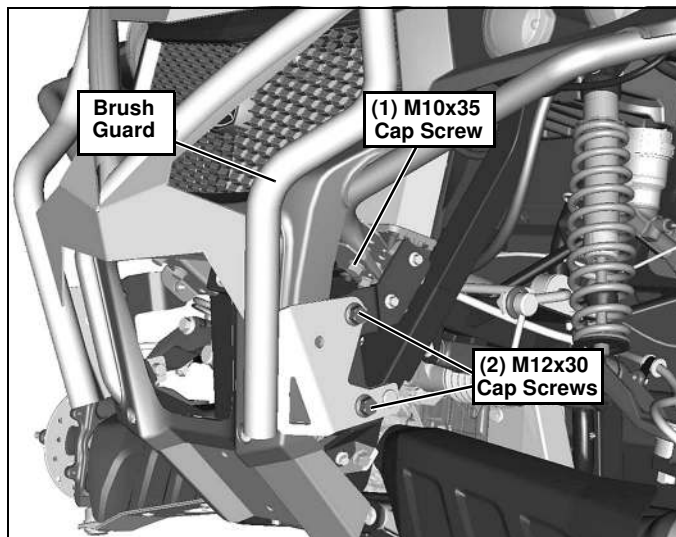

Figure 1

3. Align the holes in the side of the Upper Driver's Side Weldment (#3) with the holes in the brush guard. The top hole in the Upper Driver's Side Weldment (#3) should align with the upper front hole where the M10x35 Cap Screw was removed. (See Figure 2.)

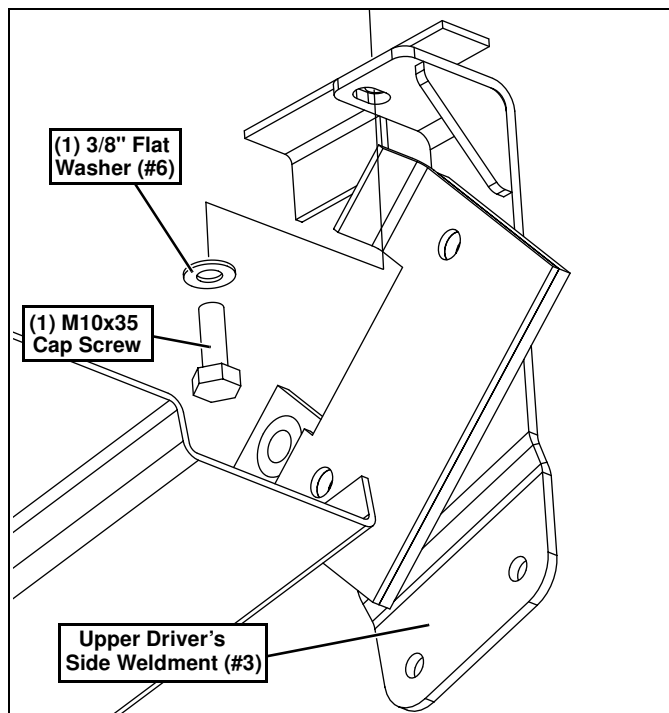

Figure 2

4. Place (1) 3/8" Flat Washer (#6) over the slot in the Upper Driver's Side Weldment (#3). Insert the original M10x35 Cap Screw removed in step 2 thru the 3/8" Flat Washer (#6), Upper Driver's Side Weldment (#3) and into the frame. (See Figure 2.)

- Place (1) 1/2" Flat Washer (#9) over only the top side hole in the Upper Driver's Side Weldment (#3). Insert (2) 1/2"-13 X 1 1/2" Cap Screws (#10) into both side holes of the Upper Driver's Side Weldment (#3), and secure with (2) 1/2"-13 Lock Nuts (#11). (See Figure 3.)

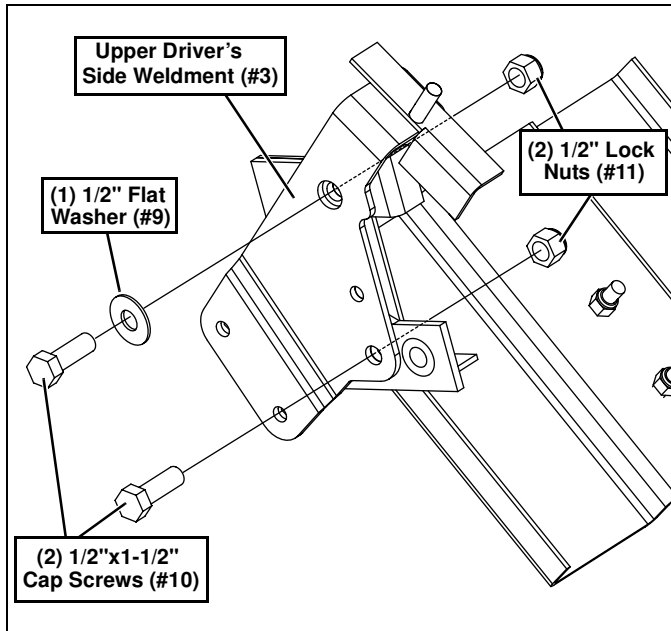

Figure 3

- Repeat Steps 2-5 on the passenger's side using the Upper Passenger's Side Weldment (#4). Then skip to step 16.
- For the Pivoting Brush Guard (on the driver's side), remove the Brush Guard Pin and M12x30 pivot Cap Screw holding the Brush Guard to the frame. Also remove the front M10x35 Cap Screw holding the Brush Guard Bracket to the frame. (See Figure 4.)

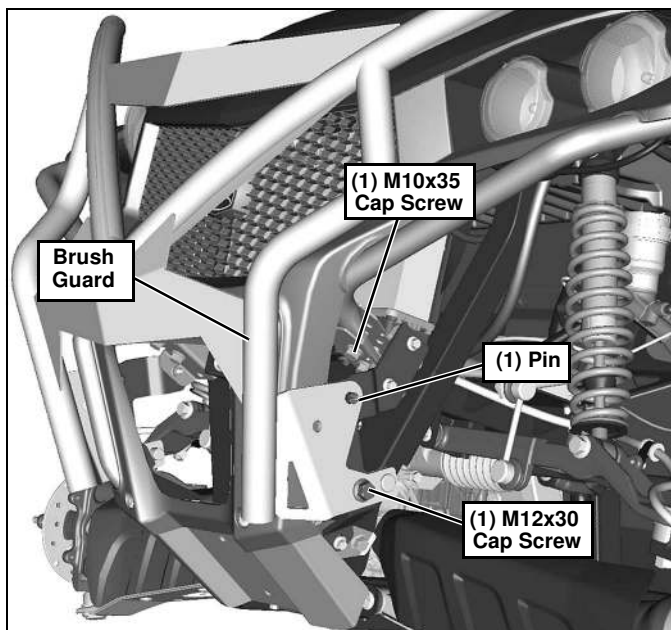

Figure 4

- Align the holes in the side of the Upper Driver's Side Weldment (#3) with the holes in the brush guard. The top hole in the Upper Driver's Side Weldment (#3) should align with the upper front hole where the M10x35 Cap Screw was removed. (See Figure 5.)

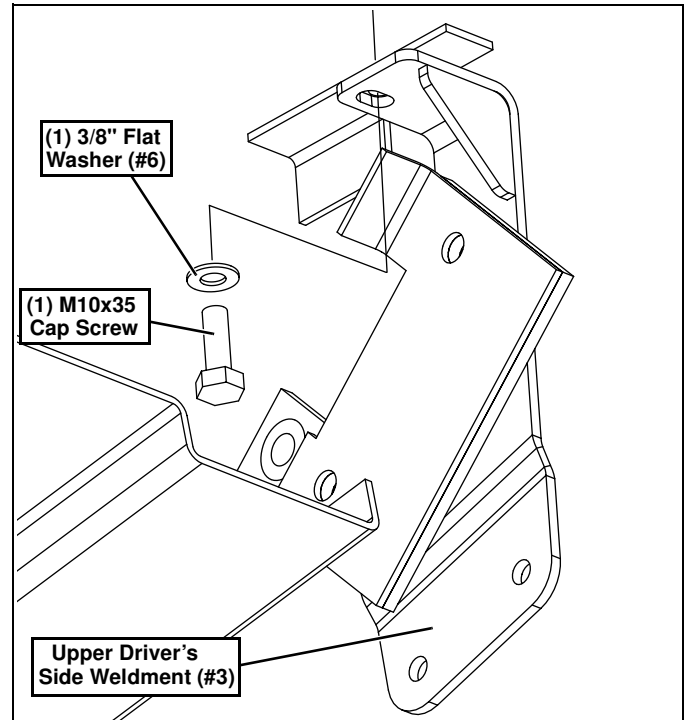

Figure 5

- Place (1) 3/8" Flat Washer (#6) over the slot in the Upper Driver's Side Weldment (#3). Insert the original M10x35 Cap Screw removed in step 7 thru the 3/8" Flat Washer (#6), Upper Driver's Side Weldment (#3) and into the frame. (See Figure 5.)
- Insert (1) 1/2"-13x1-1/2" Cap Screw (#10) into the lower side hole (pivot) of the Upper Driver's Side Weldment (#3) and secure with (1) 1/2"-13 Lock Nut (#11). (See Figure 6.)

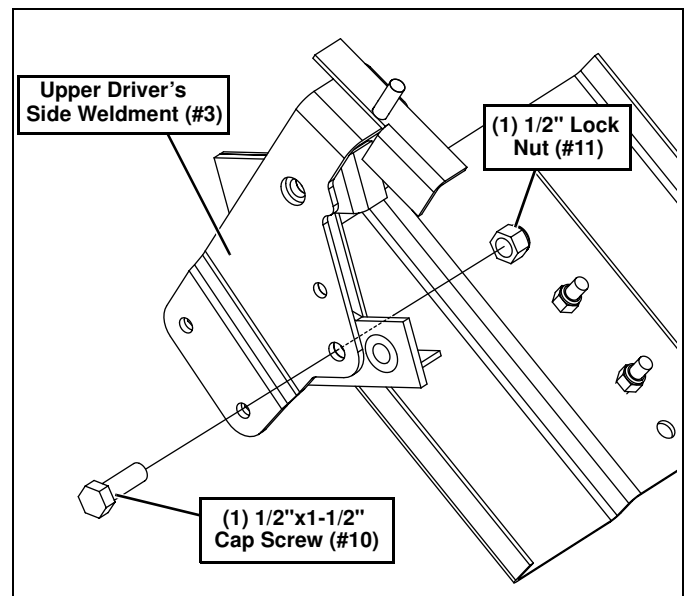

Figure 6

11. Mark the location of the center hole in the side of the Upper Driver's Side Weldment (#3). Remove the Upper Side Driver's Weldment (#3) and hardware installed in Steps 9-10. (See Figure 7.)

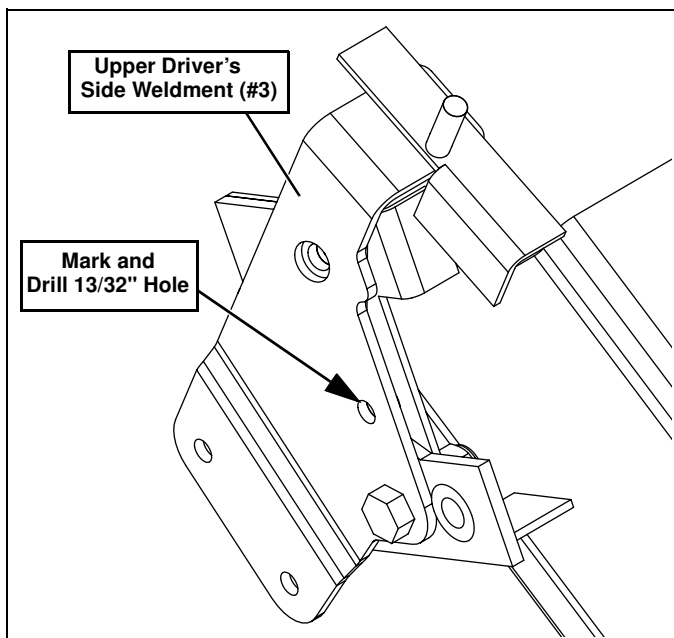

Figure 7

12. At the marked location drill a 13/32" diameter hole. (If a 13/32" drill bit is not available, use 7/16".)
13. Align the holes in the side of the Upper Driver's Side Weldment (#3) with the holes in the brush guard. The top hole in the Upper Driver's Side Weldment (#3) should align with the upper front hole where the M10x35 Cap Screw was removed. (See Figure 5.)
14. Place (1) 3/8" Flat Washer (#6) over the slot in the Upper Driver's Side Weldment (#3). Insert the original M10x35 Cap Screw removed in step 7 thru the 3/8" Flat Washer (#6), Upper Driver's Side Weldment (#3) and into the frame. (See Figure 5.)
15. Insert (1) 1/2"-13 x 1-1/2" Cap Screw (#10) into the lower side hole (pivot) of the Upper Driver's Side Weldment (#3) and secure with (1) 1/2"-13 Lock Nut (#11). (See Figure 6.)
16. Install 3/8x1-1/4" Cap Screw (#7) and 3/8" lock nut (#8) in location shown. (See Figure 8.)

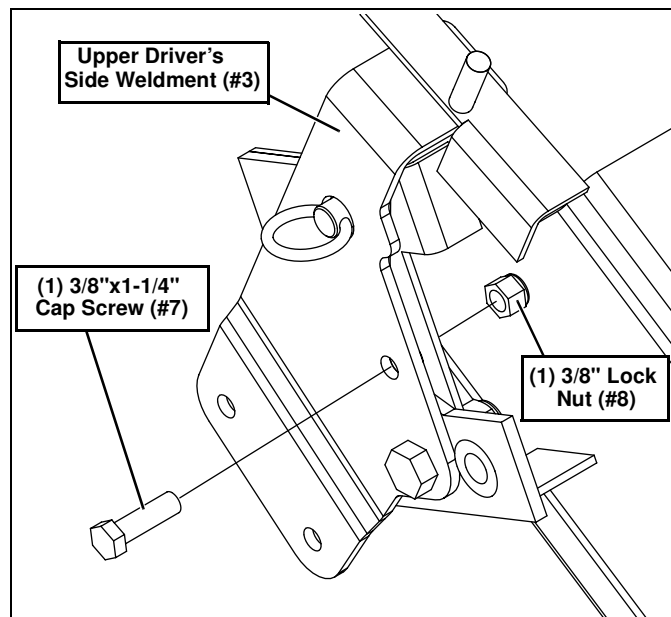

Figure 8

17. Repeat steps 7-16 on the passenger's side using the Upper Passenger's Side Weldment (#4).
18. Align the top front hole of the Lower Weldment (#2) with the top hole in the front skid plate. Insert (1) 3/8"-16x1-1/4" Cap Screw (#7) and secure with (1) 3/8"-16 Lock Nut (#8). (See Figure 9.)

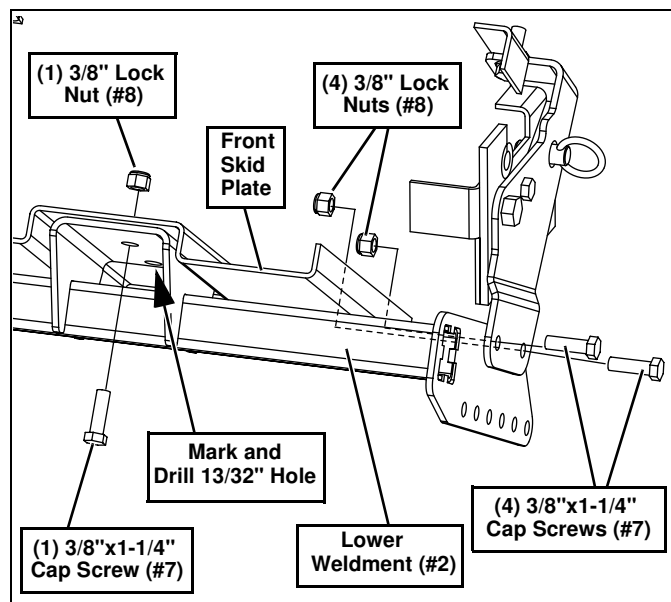

Figure 9

19. Insert (4) 3/8"-16x1-1/4" Cap Screws (#7) thru the lower side holes of the Upper Driver and Passenger Side Weldments (#3 & #4) and into the upper side holes of the Lower Weldment (#2). Secure with (4) 3/8"-16 Lock Nuts (#8). (See Figure 9.)
20. Mark the location of the lower front hole of the Lower Weldment (#2) on the Skid Plate. (See Figure 9.) Remove hardware installed in steps 18 & 19 and Lower Weldment (#2).
21. Drill a 13/32" diameter hole in the marked location. (If a 13/32" drill is not available use 7/16".)

22. Align the front holes of the Lower Weldment (#2) with the holes in the front skid plate. Insert (2) 3/8"-16x1-1/4" Cap Screws (#7) and secure with (2) 3/8"-16 Lock Nuts (#8). (See Figure 10.)

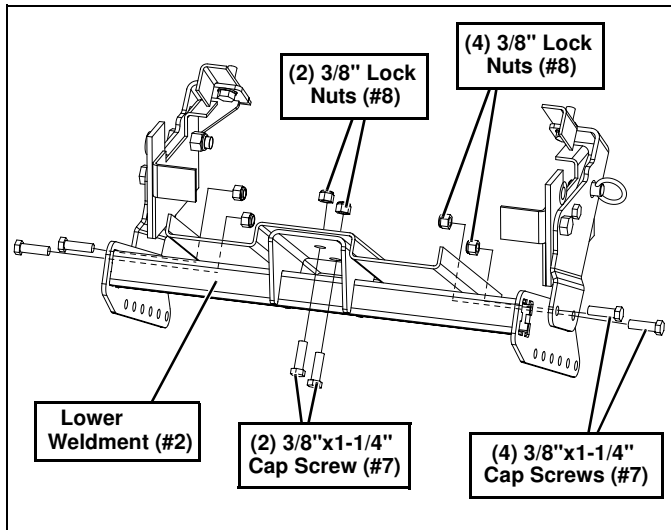

Figure 10

23. Insert (4) 3/8"-16x1-1/4" Cap Screws (#7) thru the lower side holes of the Upper Driver and Passenger Side Weldments (#3 & #4) and into the upper side holes of the Lower Weldment (#2). Secure with (4) 3/8"-16 Lock Nuts (#8). (See Figure 10.)

24. Position the UTV Mount (#1) on the machine. The UTV Mount (#1) goes between the brackets on the Lower Weldment (#2) with the (2) Spacers (#5) between the UTV Mount (#1) and the Lower Weldment (#2). (See Figure 11.)

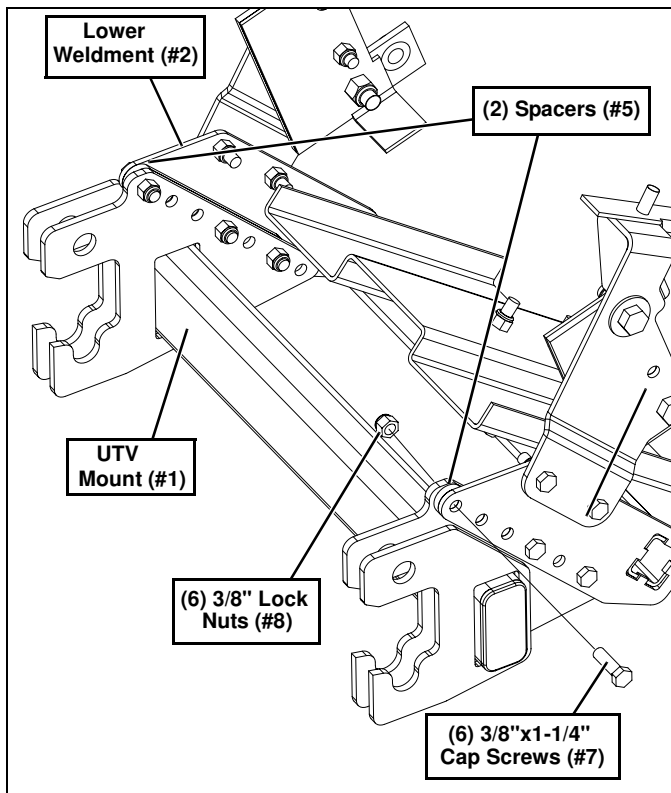

Figure 11

25. Adjust the UTV Mount (#1) on the machine to provide an 11" to 12" height between the lower pin slots and the ground. (See Figure 12.)

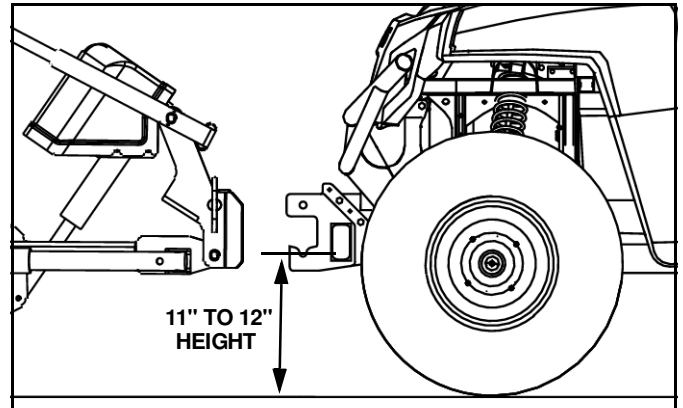

Figure 12

**IMPORTANT:** Height from the bottom of the lower pin slots on the UTV Mount to the ground should be between 11" and 12" to ensure proper operation.

26. Secure UTV Mount (#1) with (6) 3/8"-16x1-1/4" Cap Screws (#7) and (6) 3/8"-16 Lock Nuts (#8). Tighten all hardware. (See Figure 11.)

27. Tighten all hardware using the Torque Specification Chart provided.

TORQUE SPECIFICATIONS FOR STANDARD MACHINE HARDWARE					
Bolt Size	GR.2 Dry	GR.5 Dry	GR.8 Dry	Metric Size	GR.8.8 Dry
1/4"	66*	9	12	M8	17
5/16"	11	17	25	M10	35
3/8"	20	30	45	M12	60
7/16"	32	50	70	M14	95
1/2"	50	75	110	M16	155
9/16"	70	110	150		
5/8"	100	150	220		
3/4"	175	260	380		
7/8"	170	430	600		
1"	250	640	900		

These torque values are to be used for all hardware. Unless otherwise specified, all torque values must meet this specification.  
All torque values are in Ft.-Lbs unless otherwise stated  
\*In-Lbs

**REMEMBER** After 5 to 10 hours of snowplow usage, re-torque all hardware!

# PARTS LIST

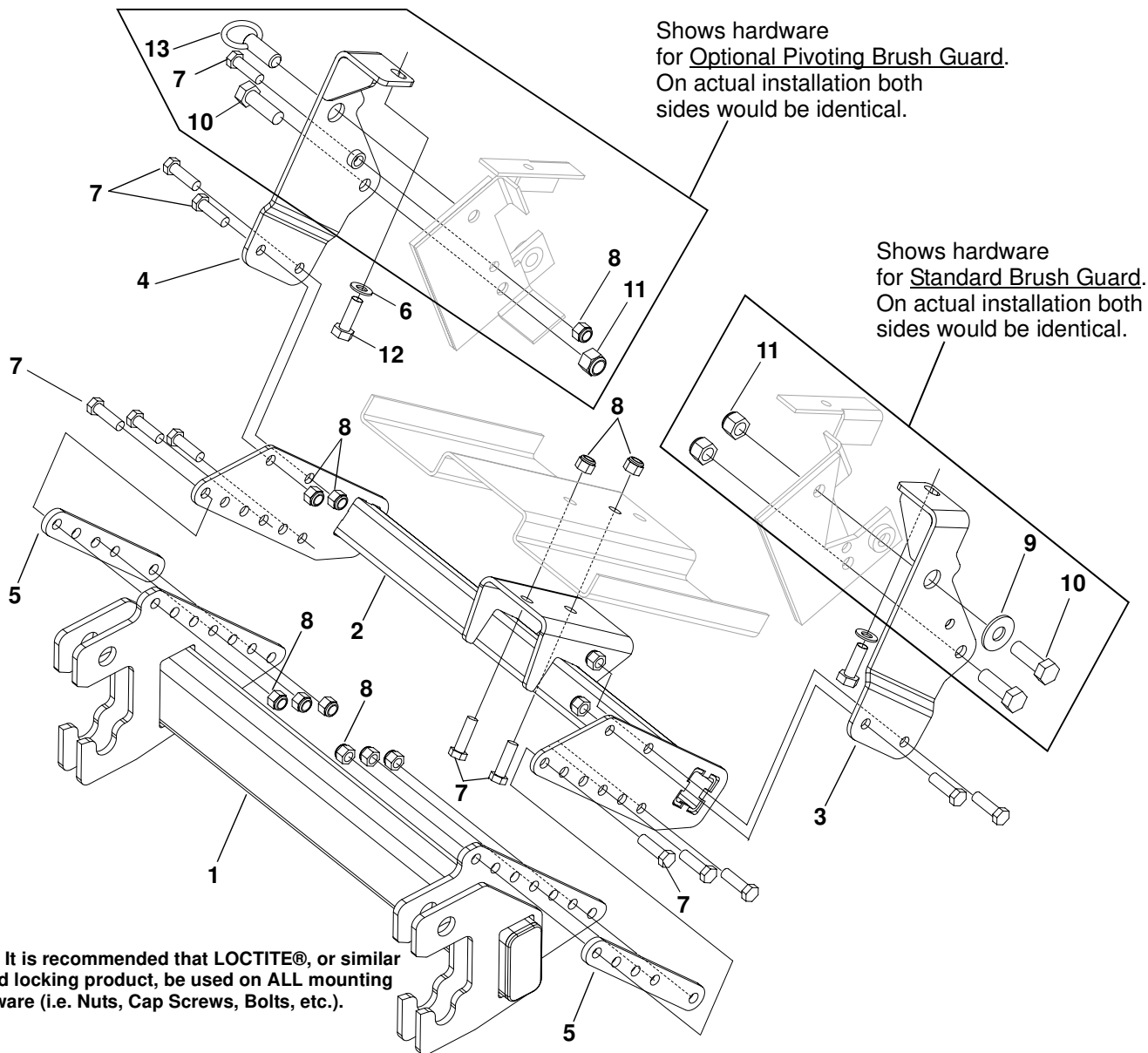

ITEM	PART NO.	DESCRIPTION	QTY.
1		UTV Mount.....	1
2		Weldment, Lower.....	1
3		Weldment, Upper Driver's Side.....	1
4		Weldment, Upper Passenger's Side.....	1
5		Spacer.....	2
6		PW, 3/8".....	2
7		HHCS, 3/8" -16 x 1-1/4".....	2
8		LN, 3/8" - 16.....	14
9		PW, 1/2".....	2
10		HHCS, 1/2" -13 x 1-1/2".....	4
11		LN, 1/2" - 13.....	4
12		HHCS, M10x35 (John Deere).....	2
13		Pin (John Deere).....	2
14	96116671	Kit, HDWE (Includes Items 5-11) (Not Shown).....	1

# NOTES

---

**SNO-WAY® INTERNATIONAL, INC.**



Hartford, WI 53027 USA  
Website: [www.snoway.com](http://www.snoway.com)  
©2017 Sno-Way® International

[www.storksplows.com](http://www.storksplows.com)