

# **SNO-WAY**®

**SNOW & ICE CONTROL EQUIPMENT**

## **ASSEMBLY & INSTALLATION INSTRUCTIONS**

**VEHICLE MOUNT KIT 99101281  
FOR UTV SERIES PLOW**

TO FIT

2015 & Later - Mahindra mPact  
2017 & Later - Mahindra Retriever  
2017 & Later - Intimidator Classic, Crew



©2019 Sno-Way® International

97102044B



1. THINK SAFETY, ALWAYS WEAR SAFETY GLASSES WHEN PERFORMING THE OPERATIONS PRESCRIBED IN THESE INSTRUCTIONS
2. READ ALL INSTRUCTIONS CAREFULLY BEFORE ATTEMPTING INSTALLATION
3. BEFORE BEGINNING WORK MAKE SURE TO SET PARKING BRAKE AND CHOCK WHEELS



### ASSEMBLY TOOLS NEEDED

Impact Sockets	1/2" - 9/16"
Wrenches	1/2" - 9/16"
Torque Wrench	
Rat Tail Pry Bar	
Hammer	

### INSTALLATION NOTES

1. Vehicle should be parked on a level surface with a normal vehicle load on the FRONT suspension.
2. On some vehicles it may be necessary to raise or stiffen the suspension to decrease the vehicles front suspension sag with the snow plow in place.
3. Unless otherwise specified, mount all Vehicle Mount Kit Components to vehicle before tightening any hardware.
4. It is recommended that LOCTITE®, or similar thread locking product, be used on ALL mounting hardware (i.e. Nuts, Cap Screws, Bolts, etc.).
5. Items in parentheses ( ) refer to quantity required for this step. Items in parentheses with a pound sign (#) indicate the part number as found in the parts list on the last page of this document.  
Example: (2) 1/2" Lock Washers (#9).

### MOUNTING INSTRUCTIONS

1. Remove the (8) 3/8" x 2-1/4" Cap Screws (#5) and (8) 3/8" Flange Nuts (#6) holding two Side Plates and Hitch Assembly. Four cap screws and nuts per side. Set aside hardware for re-installation. Retain side plates for re-installation if vehicle mount kit is removed. (See Figure 1 and Figure 2.)

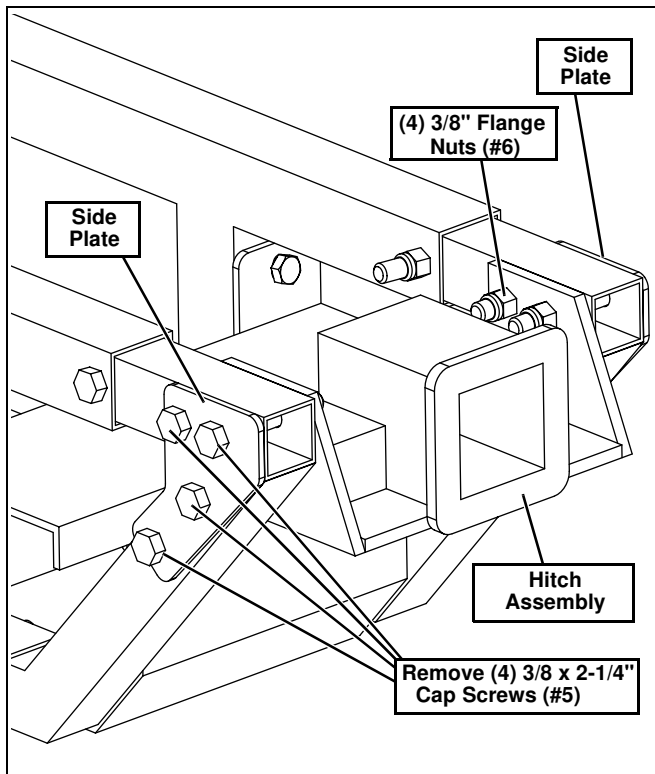

Figure 1

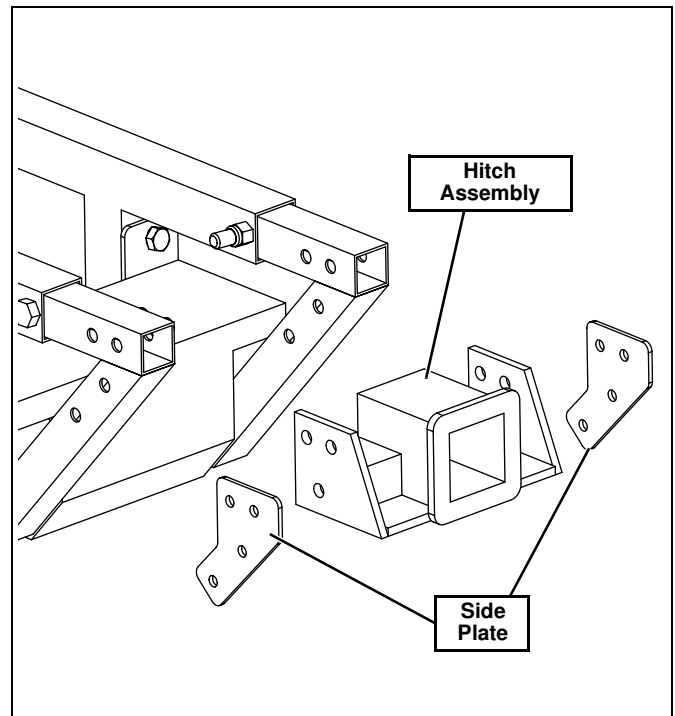

Figure 2

- Remove the lower (2) 3/8" x 2-1/4" Cap Screws (#5) and (2) 3/8" Flange Nuts (#6). Set aside hardware for installation steps. (See Figure 3.)

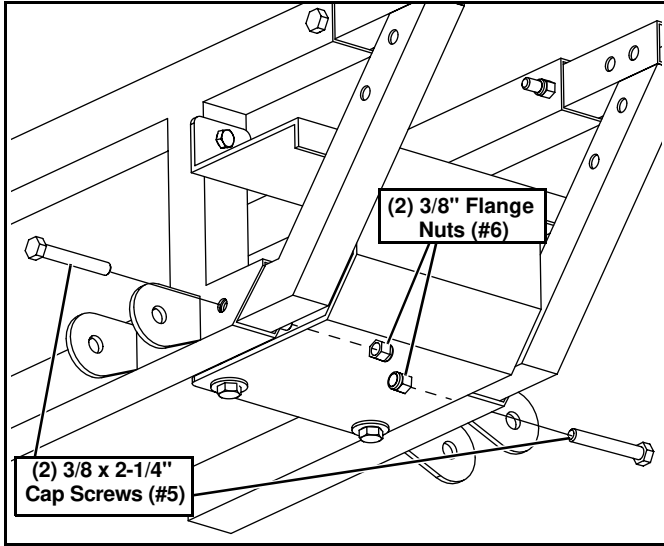

Figure 3

- Remove the lower (2) 3/8" x 1-1/4" Cap Screws (#7) and (2) 3/8" Flange Nuts (#6) in the Center Shield. Set aside hardware for installation steps. (See Figure 4.)

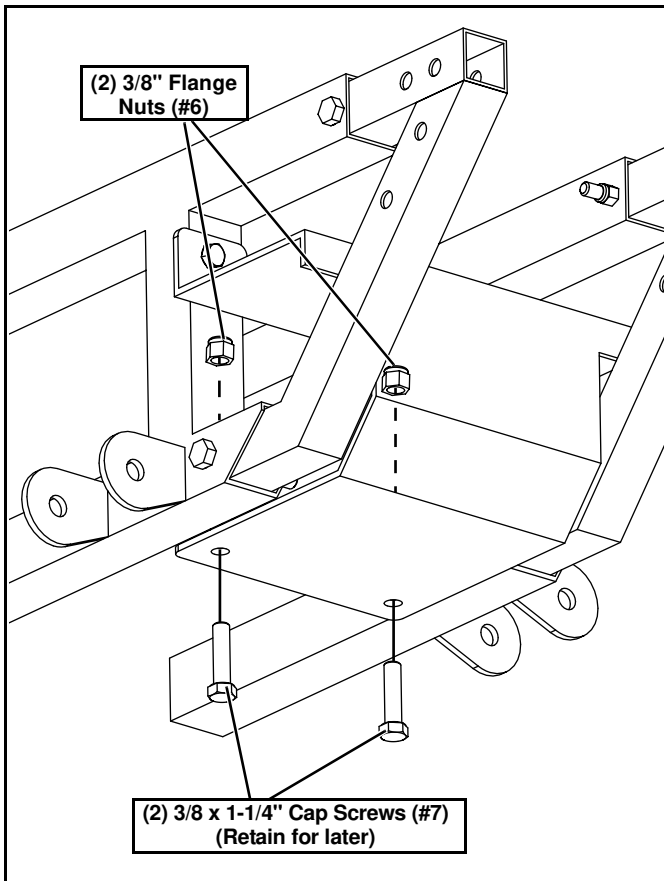

Figure 4

- Remove the two upper screws in the Center Shield. (See Figure 5.) Retain screws if mounting kit is removed.

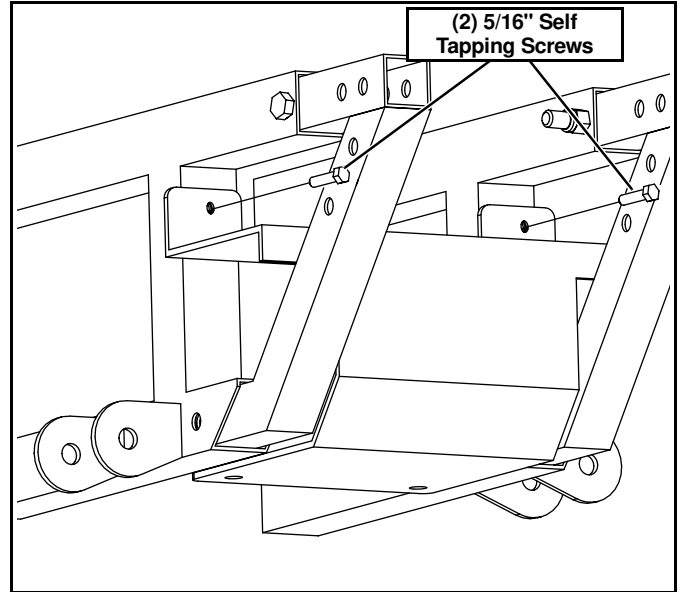

Figure 5

- Remove Center Shield and set aside for re-installation if vehicle mount kit is removed. (See Figure 6.)  
**NOTE:** You will need to turn bracket slightly in both directions in order to remove from frame.

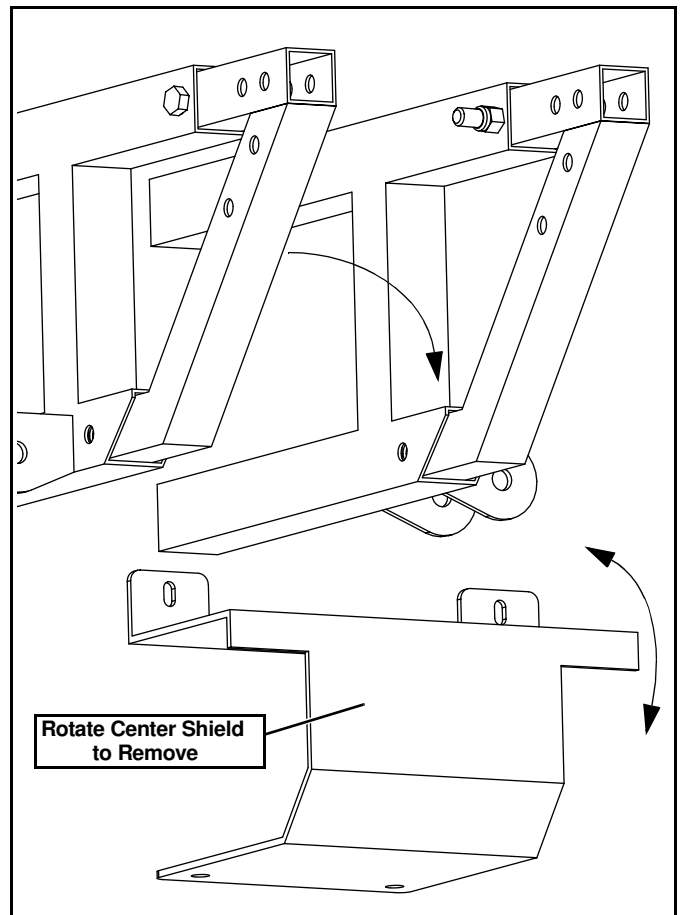

Figure 6

6. Place the Mounting Weldment (#2) onto the frame. Secure the lower side of item #2 by reinstalling the hardware that was removed from step 2. (See Figure 7.)

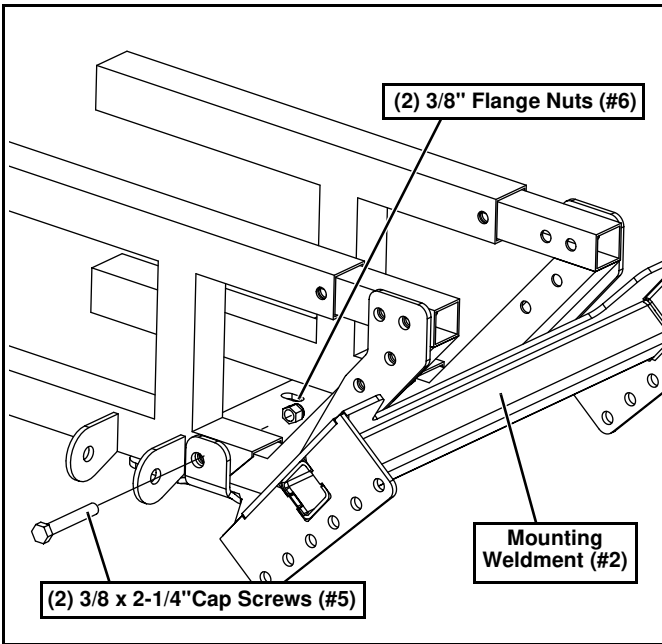

Figure 7

7. Hold Hitch Assembly in its original location. (See Figure 8.)

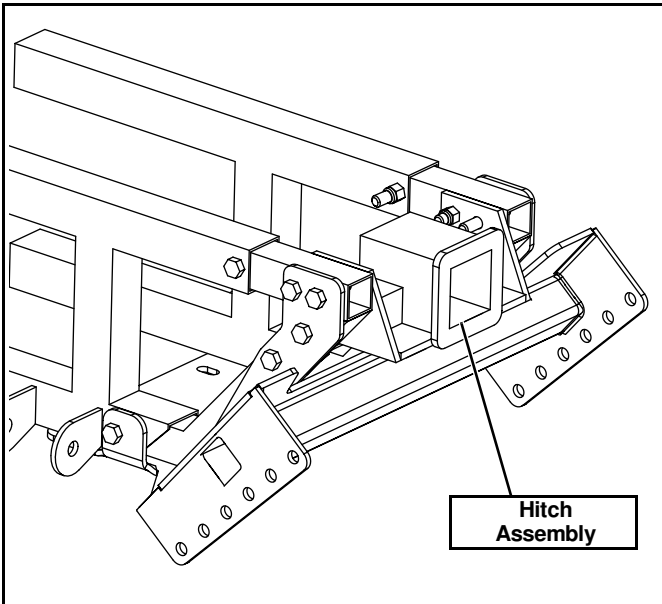

Figure 8

8. Secure the upper end of item #2 and the Hitch Assembly by reinstalling the hardware that was removed from step 1. (See Figure 8.)

9. Secure the bottom of item #2 by reinstalling the hardware that was removed from step 3, but place (1) 3/8" Plain Washer (#8) over each Cap Screw before installing. (See Figure 9.)

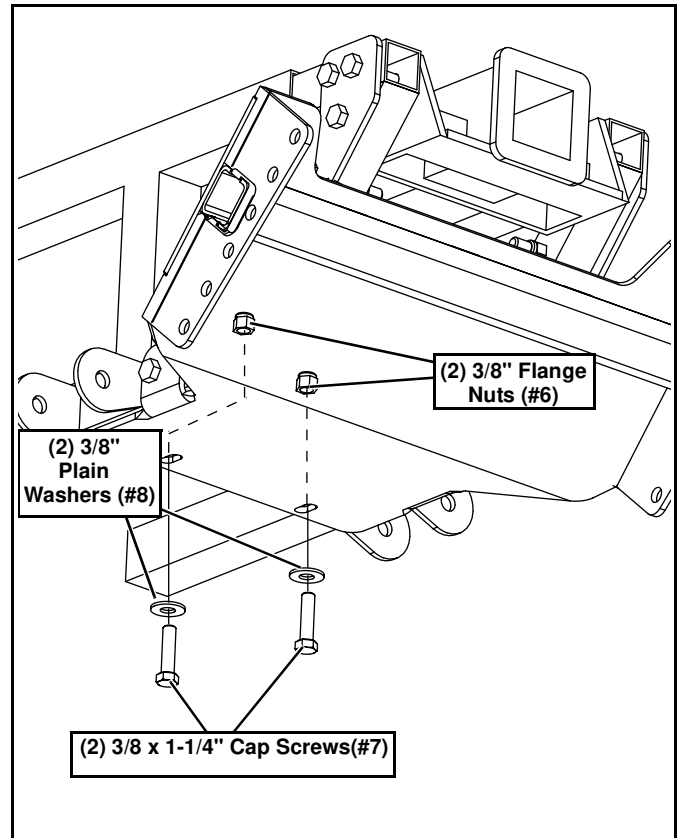

Figure 9

- Align the UTV Mount (#1) with the holes in the Mounting Weldment (#2). Adjust the UTV Mount (#1) so that the center of the bottom slot is 11-12" off of the ground. (See Figure 10.)

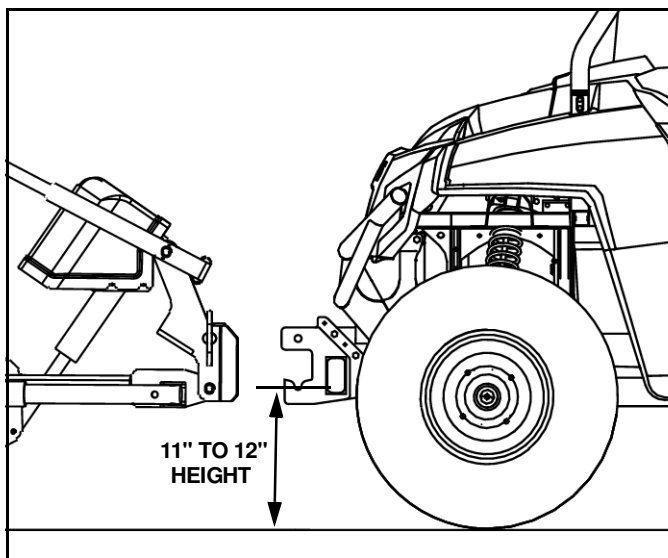

Figure 10

**IMPORTANT:** Height from the bottom of the lower pin slots on the UTV Mount to the ground should be between 11" and 12" to ensure proper operation.

- Secure the UTV Mount (#1) with (6) 3/8" x 1-1/4" Cap Screws (#4) and (6) 3/8" Locknuts (#3).
- Tighten all hardware using the Torque Specification Chart below:

TORQUE SPECIFICATIONS FOR STANDARD MACHINE HARDWARE					
Bolt Size	GR.2 Dry	GR.5 Dry	GR.8 Dry	Metric Size	GR.8.8 Dry
1/4"	66*	9	12	M8	17
5/16"	11	17	25	M10	35
3/8"	20	30	45	M12	60
7/16"	32	50	70	M14	95
1/2"	50	75	110	M16	155
9/16"	70	110	150		
5/8"	100	150	220		
3/4"	175	260	380		
7/8"	170	430	600		
1"	250	640	900		

These torque values are to be used for all hardware. Unless otherwise specified, all torque values must meet this specification.  
All torque values are in Ft.-Lbs unless otherwise stated  
\*In-Lbs

**REMEMBER** After 5 to 10 hours of snowplow usage, re-torque all hardware!

# PARTS LIST

Note: It is recommended that LOCTITE®, or similar thread locking product, be used on ALL mounting hardware (i.e. Nuts, Cap Screws, Bolts, etc.).

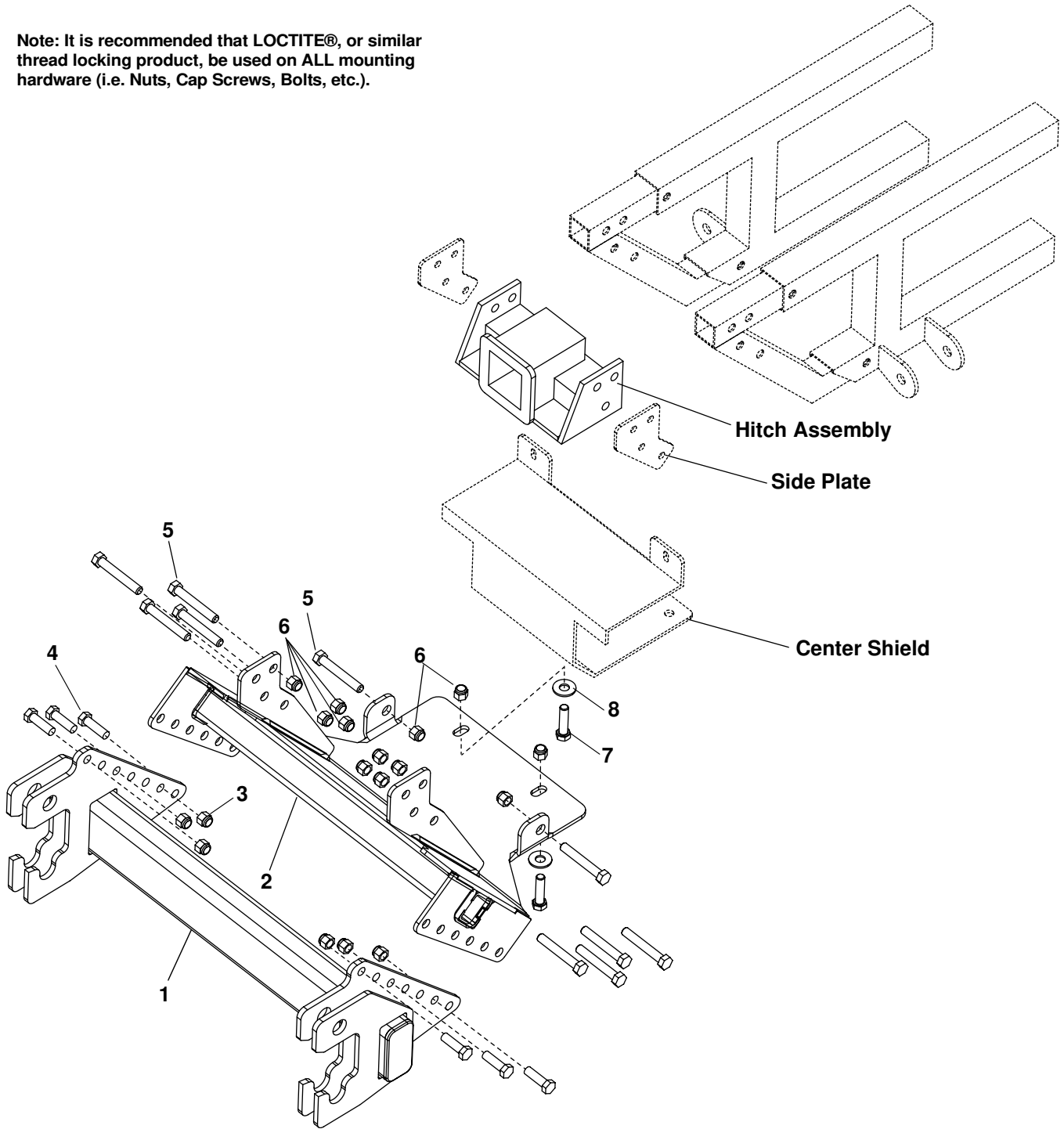

ITEM	PART NO.	DESCRIPTION	QTY.
1		UTV Mount .....	1
2		Weldment, Mounting.....	1
3		LN, 3/8"-16 .....	6
4		HHCS, 3/8"-16 x 1-1/4".....	6
5		HHCS, 3/8"-16 x 2-1/4" (Existing Hardware) .....	10
6		FN, 3/8"-16 (Existing Hardware).....	12
7		HHCS, 3/8"-16 x 1-1/4" (Existing Hardware) .....	2
8		PW, 3/8" .....	2
9	96116407	Kit, HDWE (Not Shown) (Includes items 3, 4 and 8) .....	1

# NOTES

---

**SNO-WAY® INTERNATIONAL, INC.**

**SNO-WAY**  
**SNOW & ICE CONTROL EQUIPMENT**

**[www.storksplows.com](http://www.storksplows.com)**

Hartford, WI 53027 USA  
Website: [www.snoway.com](http://www.snoway.com)  
©2019 Sno-Way® International