

SNO-WAY®

SNOW & ICE CONTROL EQUIPMENT

ASSEMBLY & INSTALLATION INSTRUCTIONS

**VEHICLE MOUNT KIT 99101284
AND
VEHICLE CENTER MEMBER
FOR 26 SERIES: 99100890
FOR 29 SERIES: 99101311**

**TO FIT
2016 - LATER NISSAN TITAN XD 4X4**

Sno-Way®· Down Pressure® and EIS® are registered trademarks of Sno-Way International, Inc.
ProControl™, MegaBlade™, V-Wing™, E-Z Switch™, Revolution™, MaxAdjust™, SpeedLock™, and
QuickJack™ are trademarks of Sno-Way International, Inc.

©2017 Sno-Way® International

97102110A



1. THINK SAFETY, ALWAYS WEAR SAFETY GLASSES WHEN PERFORMING THE OPERATIONS PRESCRIBED IN THESE INSTRUCTIONS
2. READ ALL INSTRUCTIONS CAREFULLY BEFORE ATTEMPTING INSTALLATION
3. BEFORE BEGINNING WORK MAKE SURE TO SET PARKING BRAKE AND CHOCK WHEELS



MINIMUM VEHICLE RECOMMENDATIONS

Heavy Duty Alternator

Heavy Duty Battery

NOTE: On some vehicles it may be necessary to use a form of load booster to decrease the vehicle's front suspension sag with the snow plow in place. This can be accomplished with the use of supplementary air bags, booster springs, or similar load boosting devices. Since there are different load boosting devices available, it will up to the customer/end user to decide and purchase the product to suit the application, and not the responsibility of Sno-Way International, Inc.

INSTALLATION NOTES

1. Unless otherwise specified, mount all Vehicle Mount Kit components to vehicle before tightening any hardware.
2. It is recommended that LOCTITE®, or similar thread locking product, be used on ALL mounting hardware (i.e. Nuts, Cap Screws, Bolts, etc.).
3. Vehicle should be parked on a level surface with a normal vehicle load on the FRONT suspension.
4. Items in parentheses () refer to quantity required for this step. Items in parentheses with a pound sign (#) indicate the part number as found in the parts list on the last page of this document.
Example: (10) Washer, Lock, 1/2" (#8).
5. It maybe necessary to relocate license plate holder. Check state and local laws for placement, if needed.

ASSEMBLY TOOLS NEEDED

Drill Bits	1/4 – 17/32"
Sockets	7/16" – 1-3/8"
	10mm – 18mm
Wrenches	7/16" – 1-3/8"
	10mm – 18mm
Torque Wrench	
Center Punch	
Hammer	

MOUNTING INSTRUCTIONS

1. Remove the lower valence and splash guard. Next, remove tow hooks if equipped. Retain tow hooks and hardware for reinstallation if the Vehicle Mount Kit is removed.
2. Install Driver Side Weldment (#2) by aligning the two holes in item 2 with the tow hook holes in the vehicle frame. Secure using (2) M12-1.25 x 50 mm Cap Screws (#5) and (2) 1/2" Lock Washers (#10) (See Figure 1).

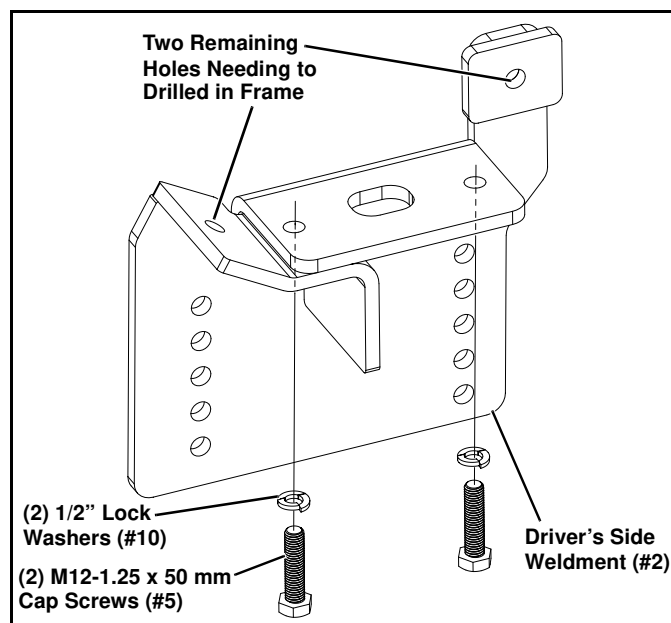

Figure 1

3. The remaining two holes against the frame need to be drilled. One in the front and one in the rear of the Driver Side Mount Weldment (#2) (See Figure 1). With item 2 against the bottom of the frame, use these holes as a template. Center punch the location, drill a 1/4" pilot, then drill to 17/32".

- Align a 1/2" Plain Washer (#7) to the front drilled hole, but between the truck frame and item 2. Insert a 1/2"-13 x 1-1/2" Handle Bolt Weldment (#6) into the front drilled hole by sticking it through the large slot in item 2 and the truck frame. Secure with a 1/2"-13 Locknut (#8) (See Figure 2).
- Insert a 1/2"-13 x 2" Handle Bolt Weldment (#9) into the rear drilled hole by sticking it through the large slot in item 2 and the truck frame. Secure with a 1/2"-13 Locknut (#8) (See Figure 2).

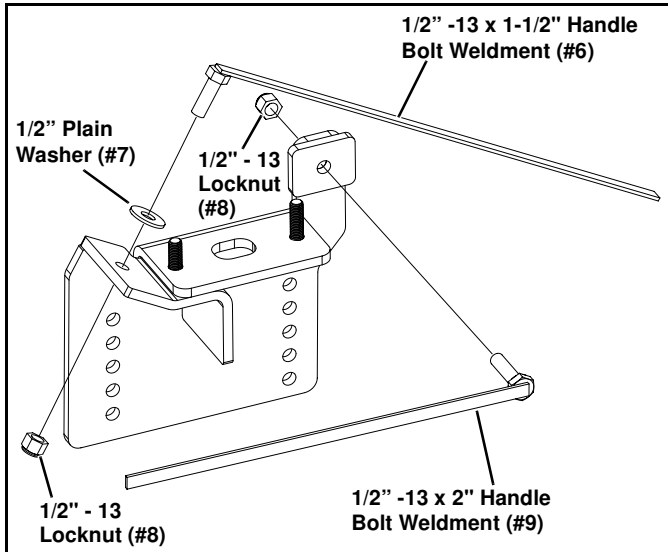

Figure 2

- Repeat steps 2-5 for the Passenger Side Mount Weldment (#3)
- Attach Vehicle Center Member (#1) to the Driver and Passenger Side Mount Weldments (#2 & 3). Secure using (4) 1/2" Spacer Plates (#4), (2) 1/2" Lock Washers (#10), (8) 1/2"-13 x 2" Cap Screws (#11), and (6) 1/2"-13 Locknuts (#8) (See Figure 3).

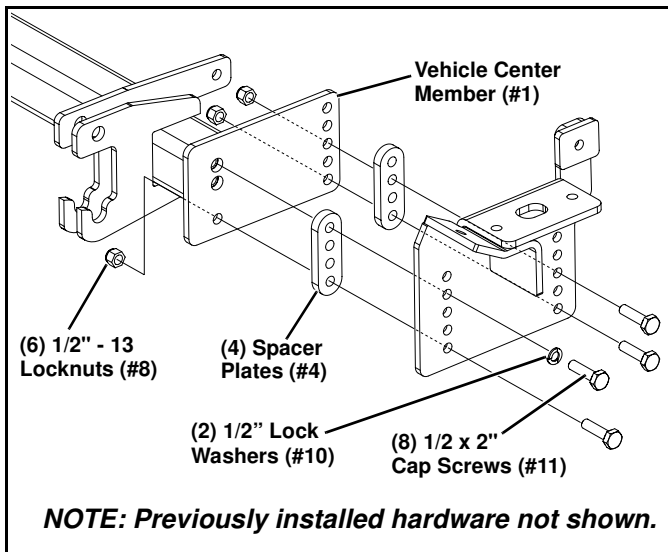

Figure 3

- Using the torque specification chart provided, torque all bolts.

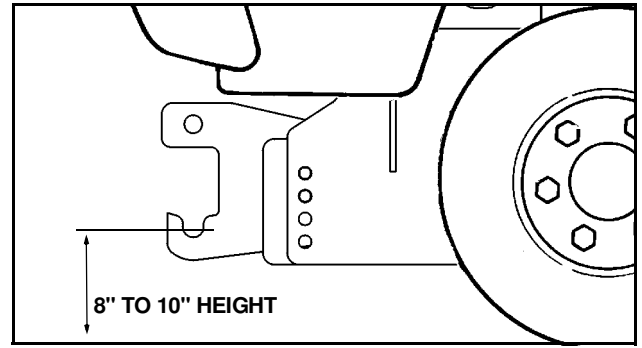

Figure 4

IMPORTANT: Height from the center of the lower plow mounting holes on the Vehicle Mount Kit to the ground should be between 8" and 10" to insure proper operation.

NOTE: When mounting to the desired height for 26 series Vehicle Center Mounts, the vehicle could either be raised or the top inside lugs of the Vehicle Center Mount can be cut off and touched up with paint so to avoid interfering with the bumper (See Figure 5).

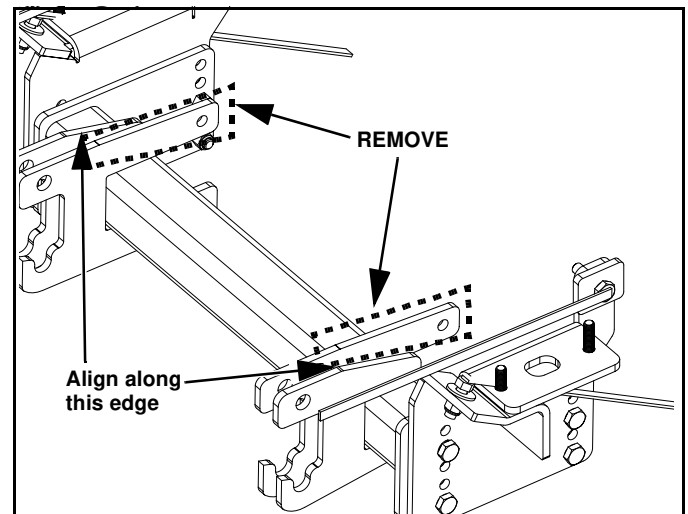

Figure 5

TORQUE SPECIFICATIONS FOR STANDARD MACHINE HARDWARE

Bolt Size	GR.2 Dry	GR.5 Dry	GR.8 Dry	Metric Size	GR.8.8 Dry
1/4"	66*	9	12	M8	17
5/16"	11	17	25	M10	35
3/8"	20	30	45	M12	60
7/16"	32	50	70	M14	95
1/2"	50	75	110	M16	155
9/16"	70	110	150		
5/8"	100	150	220		
3/4"	175	260	380		
7/8"	170	430	600		
1"	250	640	900		

Note: These torque values are to be used for all hardware. Unless otherwise specified, all torque values must meet this specification.

Note: All torque values are in Ft.-Lbs unless otherwise stated

Note: *In-Lbs

NOTE: After 5 to 10 hours of snowplow usage, re-torque all Cap Screws!

PARTS LIST

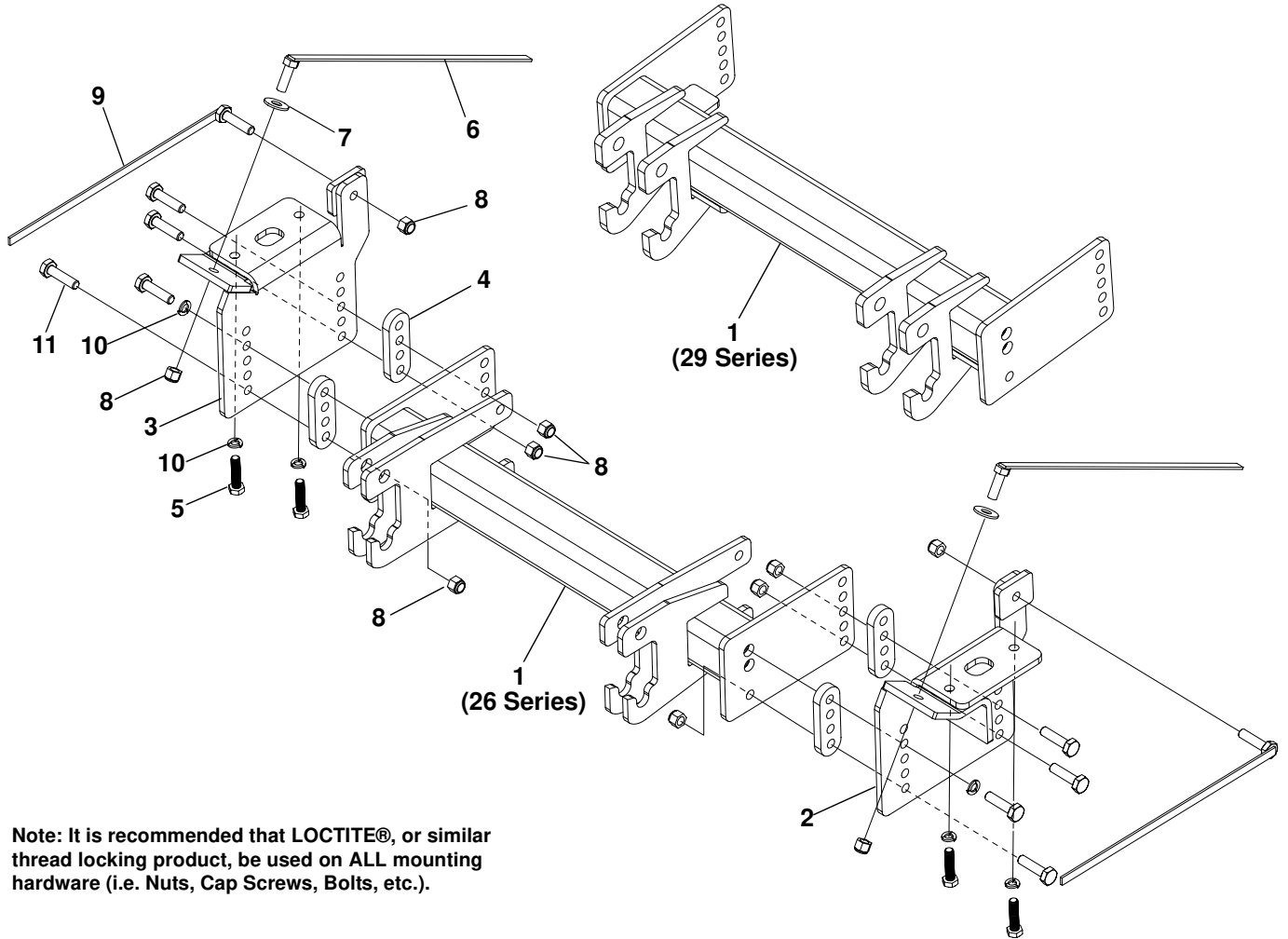

Note: It is recommended that LOCTITE®, or similar thread locking product, be used on ALL mounting hardware (i.e. Nuts, Cap Screws, Bolts, etc.).

ITEM	PART NO.	DESCRIPTION	QTY.
1	99100890	Vehicle Center Member, 26 Series	1
	99101311	Vehicle Center Member, 29 Series	1
2		Weldment, Mount, DS	1
3		Weldment, Mount, PS.....	1
4		Spacer Plate, 1/2"	4
5		HHCS, M12-1.25 x 50 mm	4
6		Handle Bolt Weldment, 1/2"-13 x 1-1/2"	2
7		PW, 1/2"	2
8		LN, 1/2"-13	10
9		Handle Bolt Weldment, 1/2"-13 x 2"	2
10		LW, 1/2"	6
11		HHCS, 1/2"-13 x 2"	8
12	96116548	Kit, HDWE (Includes items 4-11) (Not Shown)	1

SNO-WAY® INTERNATIONAL, INC.



Hartford, WI 53027 USA
 Website: www.snoway.com
 ©2017 Sno-Way® International