

SNO-WAY®

SNOW & ICE CONTROL EQUIPMENT

ASSEMBLY & INSTALLATION INSTRUCTIONS

**VEHICLE MOUNT KIT 99101300
FOR UTV SERIES PLOW**

TO FIT
2016 & Later Honda Pioneer 1000



©2017 Sno-Way® International

97102086A



1. THINK SAFETY, ALWAYS WEAR SAFETY GLASSES WHEN PERFORMING THE OPERATIONS PRESCRIBED IN THESE INSTRUCTIONS
2. READ ALL INSTRUCTIONS CAREFULLY BEFORE ATTEMPTING INSTALLATION
3. BEFORE BEGINNING WORK MAKE SURE TO SET PARKING BRAKE AND CHOCK WHEELS



ASSEMBLY TOOLS NEEDED

Impact Sockets	7/16" - 1-3/8"
Wrenches	7/16" - 1-3/8"
Torque Wrench	
Rat Tail Pry Bar	
Center Punch and Hammer	
C-Clamp	
Screwdrivers	

INSTALLATION NOTES

1. Vehicle should be parked on a level surface with a normal vehicle load on the FRONT suspension.
2. On some vehicles it may be necessary to raise or stiffen the suspension to decrease the vehicles front suspension sag with the snow plow in place.
3. Unless otherwise specified, mount all Vehicle Mount Kit Components to vehicle before tightening any hardware.
4. It is recommended that LOCTITE®, or similar thread locking product, be used on ALL mounting hardware (i.e. Nuts, Cap Screws, Bolts, etc.).
5. Items in parentheses () refer to quantity required for this step. Items in parentheses with a pound sign (#) indicate the part number as found in the parts list on the last page of this document.
Example: (2) 1/2" Lock Washers (#9).

MOUNTING INSTRUCTIONS

1. Remove the Cap Screw holding the plastic side shield to the bumper/brush guard on the side of the UTV (one on each side). (See Figure 1.)

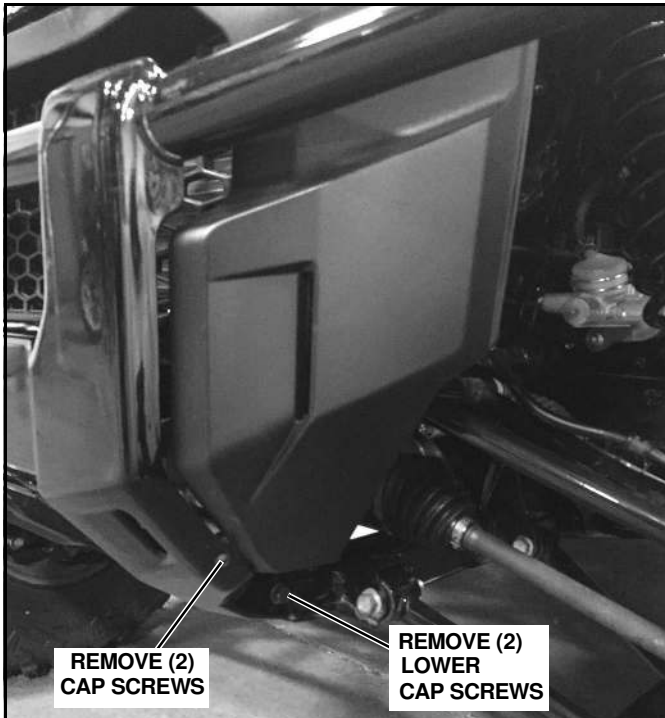

Figure 1

2. Remove the two Lower Cap Screws holding the bumper/brush guard to the frame (one on each side). (See Figure 1.)

3. Align (4) bottom holes in the Bottom Bracket (#2) with (4) holes in the bottom of the machine. Insert (4) M10-1.25 x 30 Cap Screws (#5), (4) M10 Lock Washers (#6), and (4) M10 Flat Washers (#7) through the holes in the Bottom Bracket (#2) and into the UTV. (See Figure 2.)

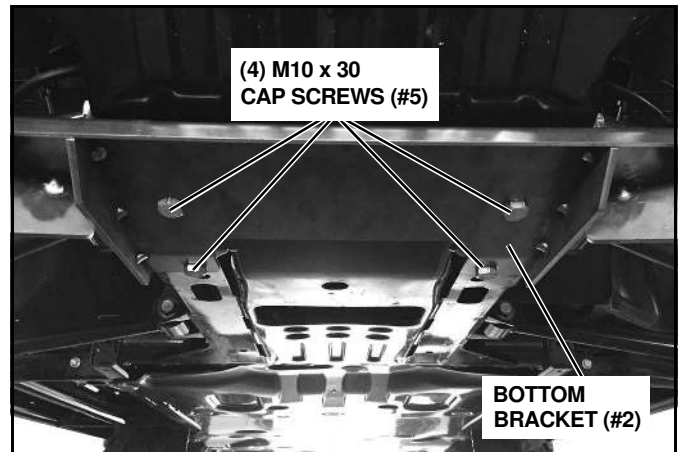

Figure 2

- Insert (2) M10-1.25 x 30 Cap Screws (#5), (2) M10 Lock Washers (#6), and (2) M10 Flat Washers (#7) into side holes of Bottom Bracket (#2), thru bumper/brush guard, and into the UTV frame. (See Figure 3.)

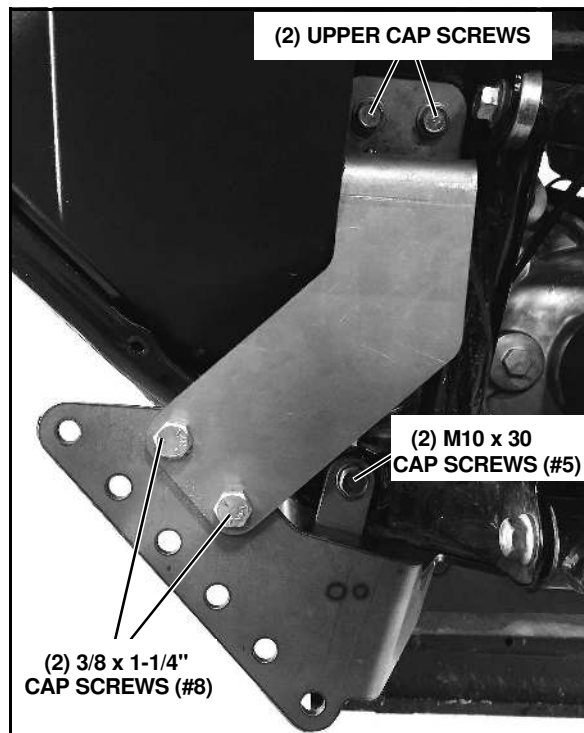

Figure 3

- On the drivers side, remove the two Upper Cap Screws that attach the bumper/brush guard to the frame. Align the holes of the Drivers Side Top Bracket (#3) with the holes in the bumper/brush guard and frame. Re-install the original two Cap Screws thru the Top Bracket (#3), bumper/brush guard, and into the frame. (See Figure 3.)
- Insert (2) 3/8"-16 x 1-1/4" Cap Screws (#8) thru the bottom holes of the Drivers Side Top Bracket (#3) and into the mating holes of the Bottom Bracket (#2). Secure with (2) 3/8"-16 Lock Nuts (#9). (See Figure 3.)
- Repeat steps 5 and 6 on the passengers side using the Passenger Side Top Bracket (#4).
- Position the UTV Mount (#1) on the machine. Align the Mount holes with the Bracket (#2) to provide an 11" to 12" height between the lower pin slots and the ground. (See Figure 4.)

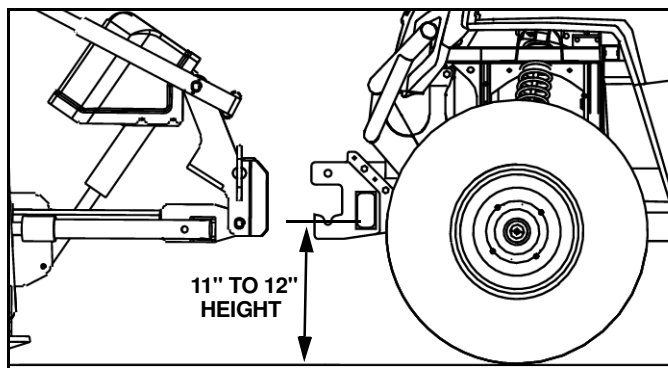

Figure 4

- Secure UTV Mount (#1) with (6) 3/8" x 1-1/4" Cap Screws (#8) and (6) 3/8" Lock Nuts (#9). (See Figure 5.) Tighten all hardware.

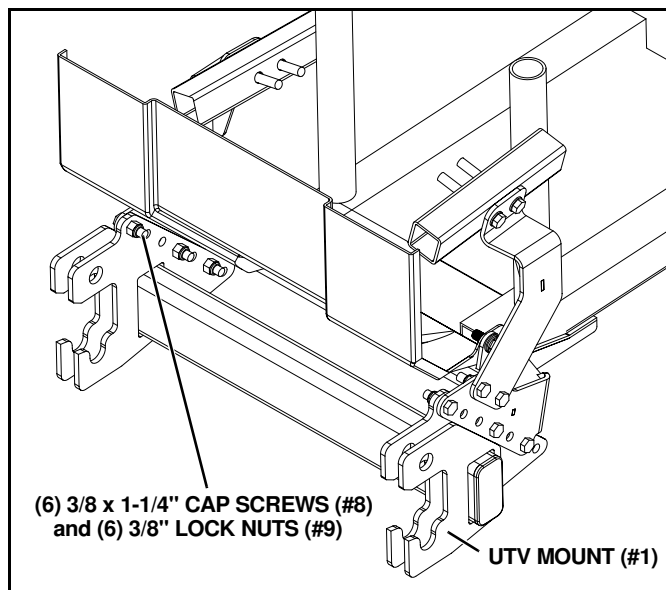

Figure 5

IMPORTANT: Height from the bottom of the lower pin slots on the UTV Mount to the ground should be between 11" and 12" to ensure proper operation.

- Torque all hardware using the Torque Specification Chart below:

TORQUE SPECIFICATIONS FOR STANDARD MACHINE HARDWARE					
Bolt Size	GR.2 Dry	GR.5 Dry	GR.8 Dry	Metric Size	GR.8.8 Dry
1/4"	66*	9	12	M8	17
5/16"	11	17	25	M10	35
3/8"	20	30	45	M12	60
7/16"	32	50	70	M14	95
1/2"	50	75	110	M16	155
9/16"	70	110	150		
5/8"	100	150	220		
3/4"	175	260	380		
7/8"	170	430	600		
1"	250	640	900		

These torque values are to be used for all hardware. Unless otherwise specified, all torque values must meet this specification.
All torque values are in Ft.-Lbs unless otherwise stated
*In-Lbs

REMEMBER After 5 to 10 hours of snowplow usage, re-torque all hardware!

- Re-install the two Cap Screws that hold the side shields removed in step 1. Trim side shields to fit around Top Brackets (# 3 & 4), if necessary.

PARTS LIST

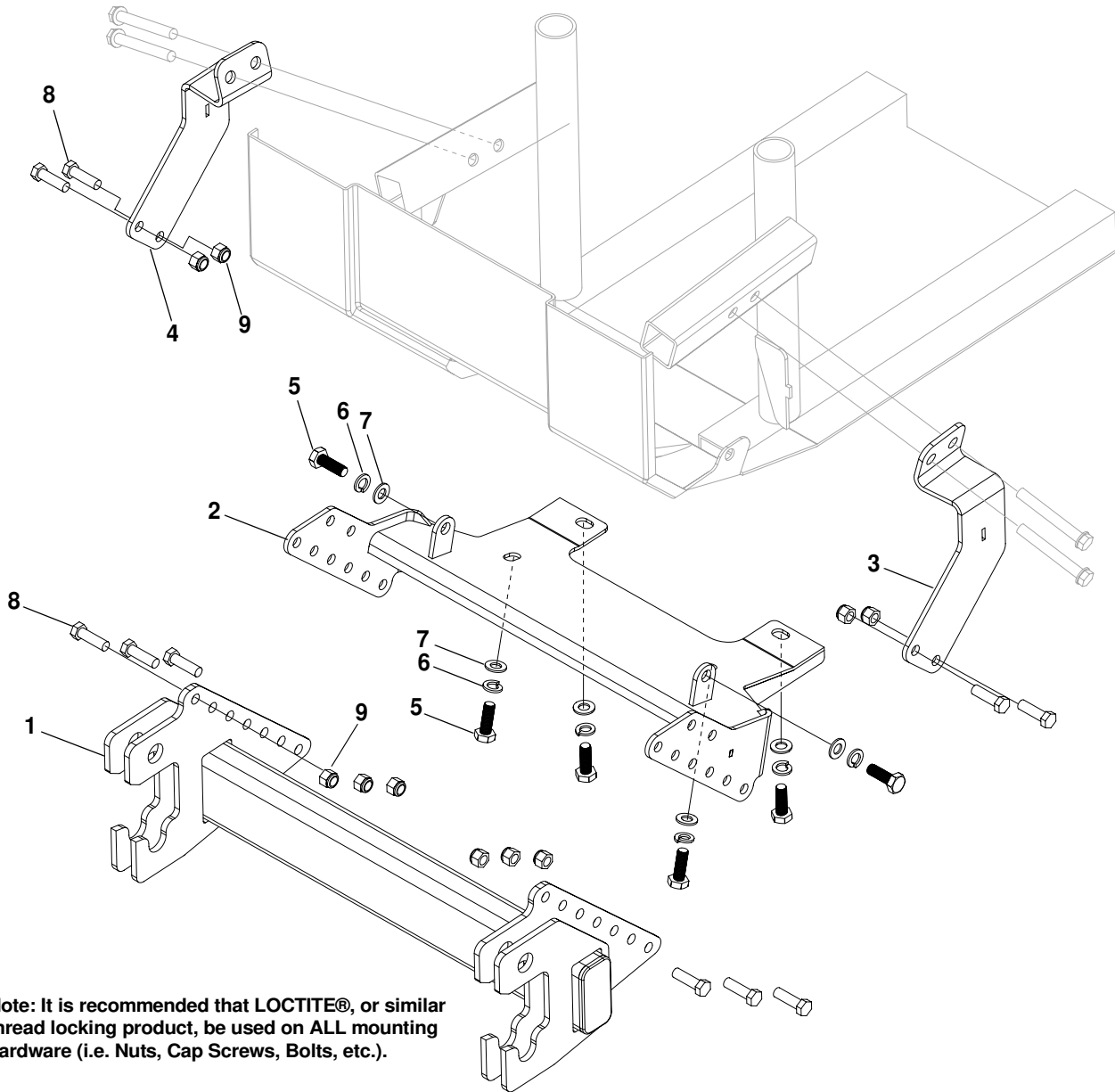

ITEM	PART NO.	DESCRIPTION	QTY.
1		UTV Mount.....	1
2		Weldment, Bracket, (Bottom) Honda Pioneer 1000.....	1
3		Weldment, Bracket (Top - DS), Honda Pioneer 1000.....	1
4		Weldment, Bracket (Top - PS), Honda Pioneer 1000.....	1
5		HHCS, M10-1.25 x 30 mm.....	6
6		LW, M10.....	6
7		PW, M10.....	6
8		HHCS, 3/8"-16 x 1-1/4".....	10
9		LN, 3/8"-16.....	10
10	96116626	Kit, HDWE (Not Shown) (Includes Items 4-9).....	1

SNO-WAY® INTERNATIONAL, INC.



Hartford, WI 53027 USA
 Website: www.snoway.com
 ©2017 Sno-Way® International