

SNO-WAY®

SNOW & ICE CONTROL EQUIPMENT

ASSEMBLY & INSTALLATION INSTRUCTIONS

**VEHICLE MOUNT KIT 99101301
FOR UTV SERIES PLOW**

TO FIT
2017 & Later - Can Am Defender



©2018 Sno-Way® International

97102101B



1. THINK SAFETY, ALWAYS WEAR SAFETY GLASSES WHEN PERFORMING THE OPERATIONS PRESCRIBED IN THESE INSTRUCTIONS



2. READ ALL INSTRUCTIONS CAREFULLY BEFORE ATTEMPTING INSTALLATION

3. BEFORE BEGINNING WORK MAKE SURE TO SET PARKING BRAKE AND CHOCK

ASSEMBLY TOOLS

Impact Sockets	5/16" - 1-3/8"
Impact Sockets	5 mm - 16 mm
Wrenches	5/16" - 1-3/8"
Wrenches	5 mm - 16 mm
Torque Wrench	Tape Measure
Screwdriver, Flat Blade	

INSTALLATION NOTES

1. Vehicle should be parked on a level surface with a normal vehicle load on the FRONT suspension.

2. On some vehicles it may be necessary to raise or stiffen the suspension to decrease the vehicles front suspension sag with the snow plow in place.

3. Unless otherwise specified, mount all Vehicle Mount Kit Components to vehicle before tightening any hardware.

4. It is recommended that LOCTITE®, or similar thread locking product, be used on ALL mounting hardware (i.e. Nuts, Cap Screws, Bolts, etc.).

5. Items in parentheses () refer to quantity required for this step. Items in parentheses with a pound sign (#) indicate the part number as found in the parts list on the last page of this document.

Example: (2) 1/2" Lock Washers (#9).

MOUNTING INSTRUCTIONS

1. Open hood and remove the (4) fasteners (2 on each side) that hold the driver and passenger side fenders. (See Figure 1.)

2. Gently pull the drivers side fender away from the UTV to gain access to the (1) Cap Screw and (1) Nut that hold the top of the bumper/brush guard in place. Loosen but do not remove the (1) Cap Screw and (1) Nut. (See Figure 2.)

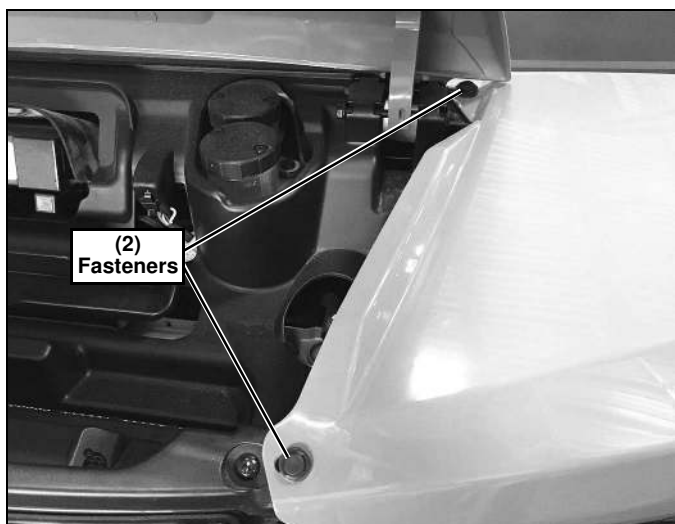

Figure 1

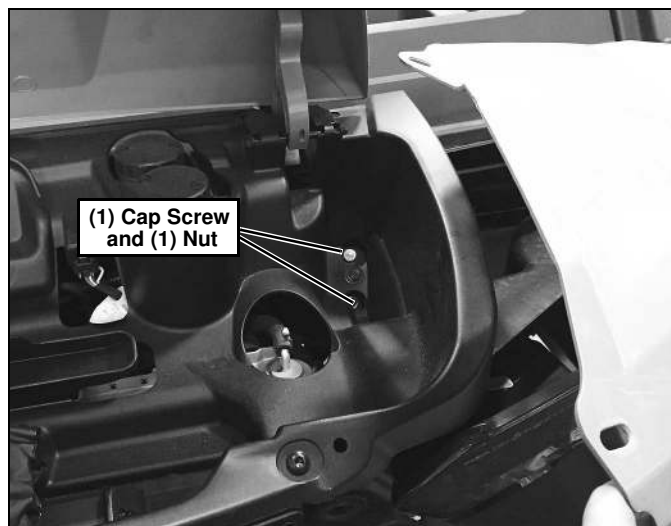

Figure 2

3. Repeat step 2 on the passenger side. NOTE: It is necessary to remove the owner's package as well as pull the passenger side fender back to gain access to the (1) Cap Screw and (1) Nut. (See Figure 3 and Figure 4.)

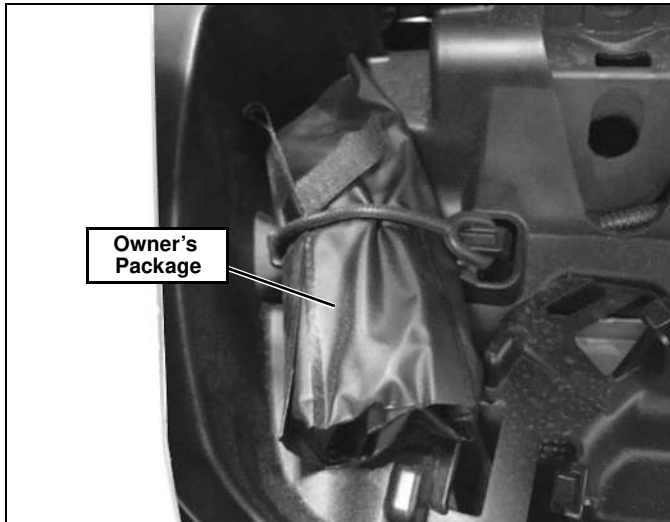

Figure 3

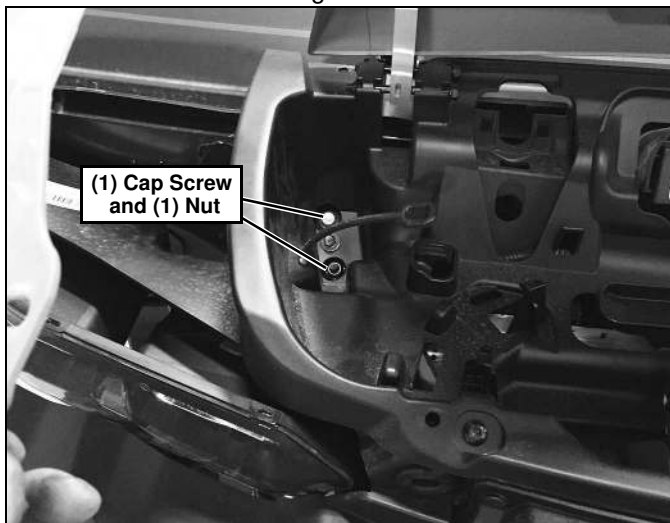

Figure 4

4. Remove (2) Cap Screws that hold the lower bumper/brush guard to the frame. Pull bumper brush guard forward and insert the front lip of the Lower Bracket (#2) between the bumper brush guard and frame. (See Figure 5 and Figure 6.)

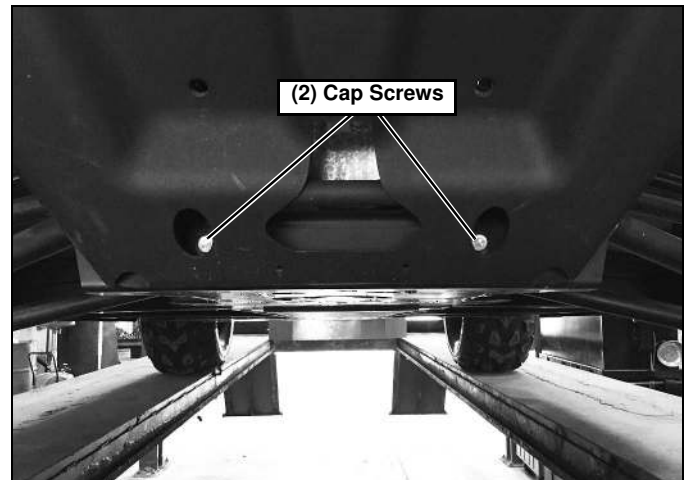

Figure 5

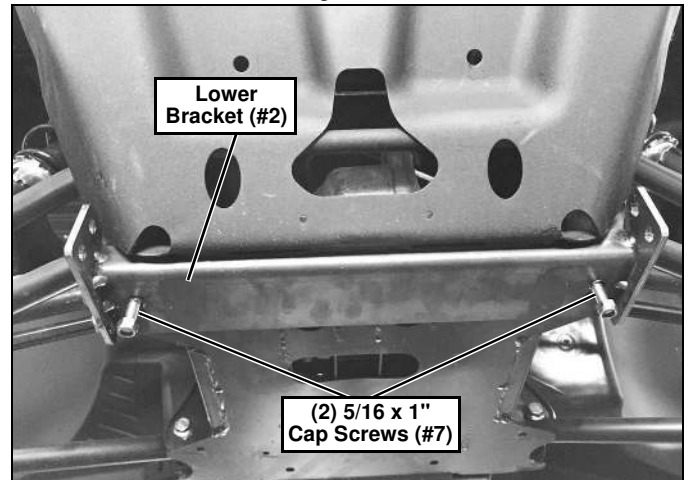

Figure 6

5. Align the holes in the bumper/brush guard, Lower Bracket (#2), and frame. Re-install but do not tighten the (2) Cap Screws removed in step 4.

6. Insert (2) 5/16"-18 x 1" Cap Screws (#7) into the holes in the bottom of the frame below the A-arms and thru the matching holes in the Lower Bracket (#2). Secure with (2) 5/16" Flat Washers (#8) and (2) 5/16"-18 Lock Nuts (#9). (See Figure 6.)

7. Align the (4) winch mount holes in the bumper/brush guard with the (4) top holes in the Upper Bracket (#3). Insert (4) 3/8"-16 x 1-1/4" (#4) Cap Screws into the Upper Bracket (#3) holes and thru the bumper/brush guard. Secure with (4) 3/8"-16 Lock Nuts (#6). (See Figure 7.)

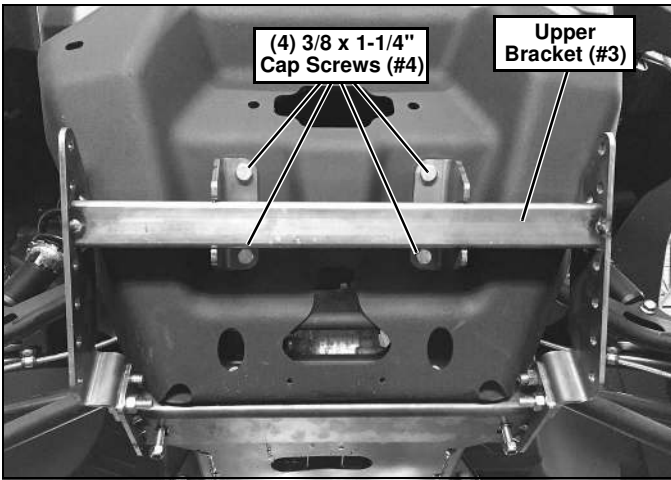

Figure 7

NOTE: If a factory winch is installed remove the Cap Screws securing the winch, insert the Upper Bracket (#3), and install M8-1.25 x 30 Cap Screws in place of 3/8" x 1-1/4" Cap Screws (#4).

8. Insert (4) 3/8"-16 x 1" Cap Screws (#5) into the rear side holes of the Upper Bracket (#3) and thru the Lower Bracket (#2). Secure with (4) 3/8"-16 Lock Nuts (#6). (See Figure 8.)

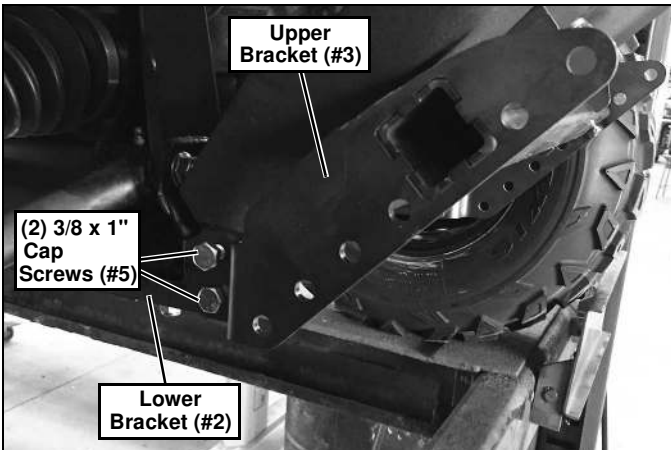

Figure 8

9. Tighten the Upper and Lower bumper/brush guard Cap Screws loosened and removed in steps 2-4.

10. Re-install fasteners that secure drivers and passenger side fenders removed in step 1. Insert owner's package.

11. Position the UTV Mount (#1) on the machine. Align the Mount holes with the Upper Bracket (#3) to provide an 11" to 12" height between the lower pin slots and the ground. (See Figure 9.)

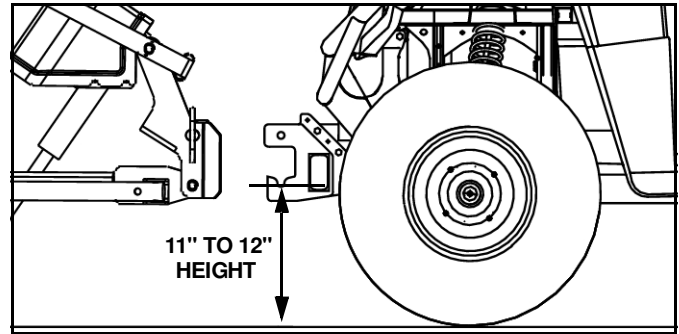

Figure 9

12. Secure UTV Mount (#1) with (6) 3/8"-16 x 1-1/4" Cap Screws (#4) and (6) 3/8"-16 Lock Nuts (#6). Tighten all hardware. (See Figure 10.)

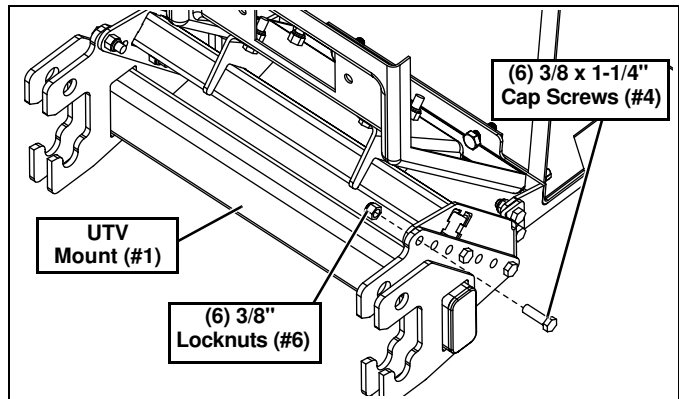

Figure 10

IMPORTANT: Height from the bottom of the lower pin slots on the UTV Mount to the ground should be between 11" and 12" to ensure proper operation.

13. Torque all hardware using the Torque Specification Chart below:

TORQUE SPECIFICATIONS FOR STANDARD MACHINE HARDWARE					
Bolt Size	GR.2 Dry	GR.5 Dry	GR.8 Dry	Metric Size	GR.8.8 Dry
1/4"	66*	9	12	M8	17
5/16"	11	17	25	M10	35
3/8"	20	30	45	M12	60
7/16"	32	50	70	M14	95
1/2"	50	75	110	M16	155
9/16"	70	110	150		
5/8"	100	150	220		
3/4"	175	260	380		
7/8"	170	430	600		
1"	250	640	900		

These torque values are to be used for all hardware. Unless otherwise specified, all torque values must meet this specification. All torque values are in Ft.-Lbs unless otherwise stated
*In-Lbs

REMEMBER After 5 to 10 hours of snowplow usage, re-torque all hardware!

PARTS LIST

Note: It is recommended that LOCTITE®, or similar thread locking product, be used on ALL mounting hardware (i.e. Nuts, Cap Screws, Bolts, etc.).

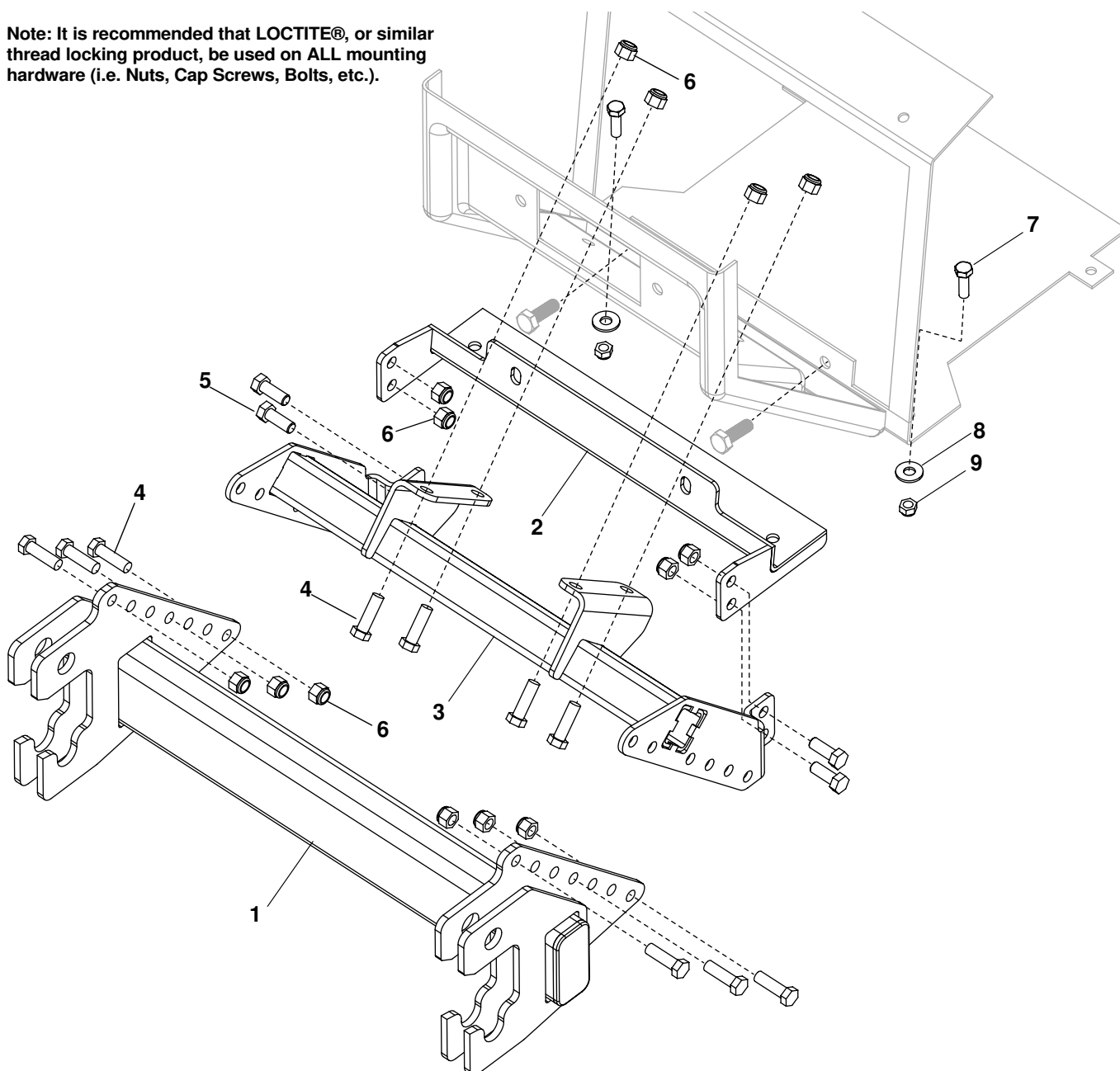

ITEM	PART NO.	DESCRIPTION	QTY.
1		UTV Mount.....	1
2		Weldment, Lower Mounting	1
3		Weldment, Upper Mounting	1
4		HHCS, 3/8"-16 x 1-1/4"	10
5		HHCS, 3/8"-16 x 1"	4
6		LN, 3/8"-16.....	14
7		HHCS, 5/16"-18 x 1	2
8		PW, 5/16"-.....	2
9		LN, 5/16"-18.....	2
10	96116652	Kit, HDWE (Not Shown) (Includes Items 4-9).....	1

NOTES

NOTES

SNO-WAY® INTERNATIONAL, INC.



Hartford, WI 53027 USA
Website: www.snoway.com
©2018 Sno-Way® International

www.storksplows.com