

SNO-WAY®

SNOW & ICE CONTROL EQUIPMENT

ASSEMBLY & INSTALLATION INSTRUCTIONS

**VEHICLE MOUNT KIT 99101309
AND
VEHICLE CENTER MEMBER 99100890**

**TO FIT:
2019 & LATER CHEVY SILVERADO PICKUP 4X4 (NEW BODY)
2019 & LATER GMC SIERRA PICKUP 4X4 (NEW BODY)**

©2018 Sno-Way® International

97102133A



1. THINK SAFETY, ALWAYS WEAR SAFETY GLASSES WHEN PERFORMING THE OPERATIONS PRESCRIBED IN THESE INSTRUCTIONS
2. READ ALL INSTRUCTIONS CAREFULLY BEFORE ATTEMPTING INSTALLATION
3. BEFORE BEGINNING WORK MAKE SURE TO SET PARKING BRAKE AND CHOCK WHEELS



MINIMUM VEHICLE RECOMMENDATIONS

Heavy Duty Alternator
Heavy Duty Battery

NOTE: On some vehicles it may be necessary to use a form of load booster to decrease the vehicle's front suspension sag with the snow plow in place. This can be accomplished with the use of supplementary air bags, booster springs, or similar load boosting devices. Since there are different load boosting devices available, it will up to the customer/end user to decide and purchase the product to suit the application, and not the responsibility of Sno-Way International, Inc.

ASSEMBLY TOOLS NEEDED

| | |
|-------------------------|----------------|
| Drill Bits | 1/4", 17/32" |
| Impact Sockets | 7/16" – 1-3/8" |
| Metric Sockets | 10 mm – 18 mm |
| Wrenches | 7/16" – 1-3/8" |
| Metric Wrenches | 10 mm – 18 mm |
| Torque Wrench | |
| Cutting Wheel/Sawzall | |
| Center Punch and Hammer | |
| Touch Up Paint | |

INSTALLATION NOTES

1. Unless otherwise specified, mount all Vehicle Mount Kit Components to vehicle before tightening any hardware.
2. It is recommended that LOCTITE®, or similar thread locking product, be used on ALL mounting hardware (i.e. Nuts, Cap Screws, Bolts, etc.).
3. Vehicle should be parked on a level surface with a normal vehicle load on the FRONT suspension.
4. Items in parentheses () refer to quantity required for this step. Items in parentheses with a pound sign (#) indicate the part number as found in the parts list on the last page of this document.
Example: (2) 1/2"-13 x 1-1/2" Cap Screws (#8).
5. It may be necessary to relocate license plate holder. Check state and local laws for placement, if needed.

MOUNTING INSTRUCTIONS

NOTE: Sno-Way does NOT recommend Vehicles equipped with Adaptive Cruise Control and/or Crash Imminent Braking. Vehicles, if equipped, may need to turn the following packages or features OFF because of possible interference with the attached plow and/or spreader: Forward Collision Alert, Lane Departure Warning, Rear Cross Traffic Alert.

1. Remove bumper and retain hardware for reinstallation.
2. Remove the Lower Valance Brackets and retain with hardware for use if vehicle mount kit is ever removed. (See Figure 1.)

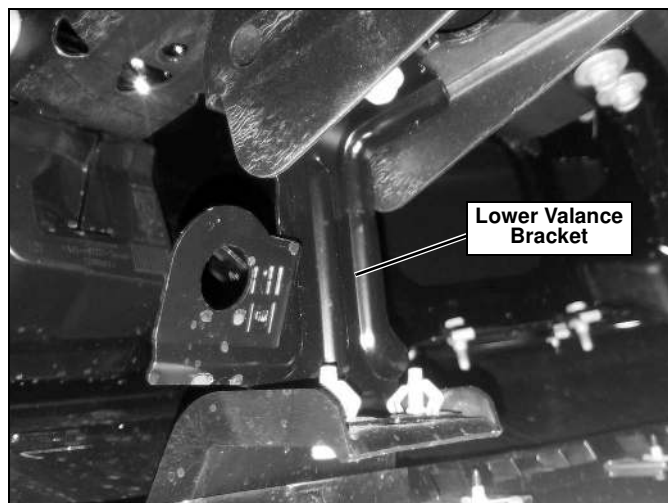

Figure 1

3. Remove any tow hooks and retain with hardware, for use if vehicle mount kit is ever removed.
4. Remove the splash guard between the frame rails, along with the nut clip held into the frame. (See Figure 2.)

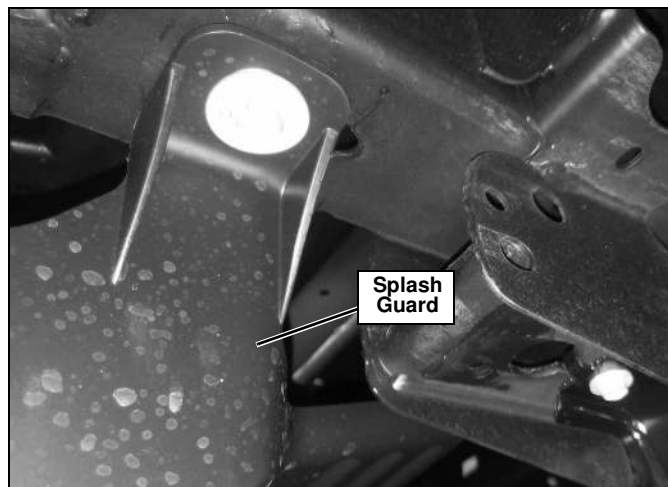

Figure 2

5. Hold the Driver's Side Mount Weldment (#2) to the driver side frame rail. Align the two front holes and two middle holes with the holes in the frame. (See Figure 3.)

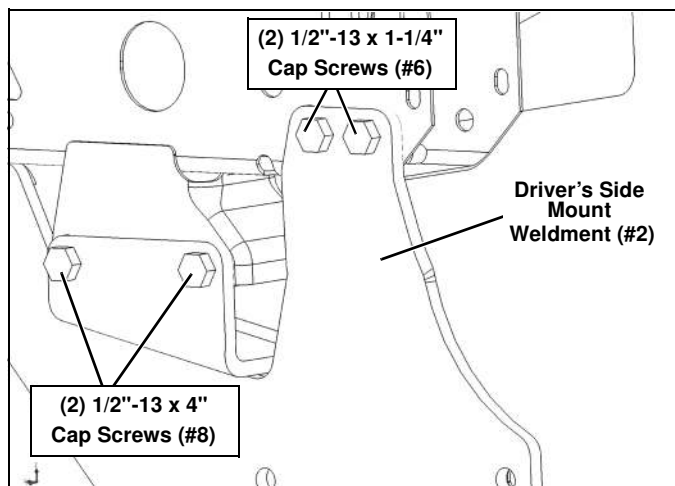

Figure 3

6. In the front holes, attach using (2) 1/2"-13 x 1-1/4" Cap Screws (#6) and (2) 1/2"-13 Locknuts (#10). (See Figure 3.)
7. In the middle holes, attach using (2) 1/2"-13 x 4" Cap Screws (#8) and (2) 1/2"-13 Locknuts (#10). (See Figure 3.)
8. Place a Bearing Plate (#4) in the driver side frame rail, and align with the rear hole of the Driver's Side Mount Weldment (#2) and the hole the splash guard was held from step 4. Attach the Bearing Plate (#4), frame rail, and Driver's Side Mount Weldment (#2) using (1) 1/2"-13 x 1-1/2" x 20" Handle Bolt Weldment (#9) and (1) 1/2"-13 Locknut (#10). (See Figure 4.)

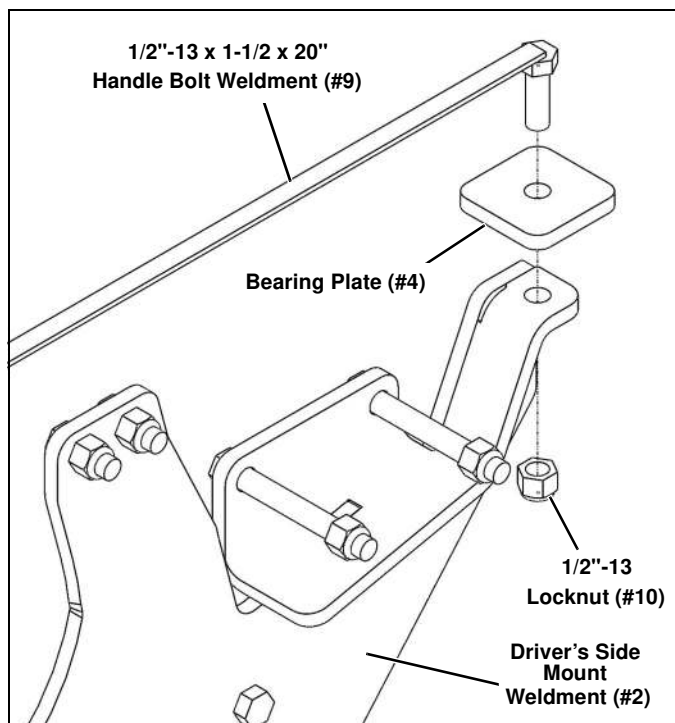
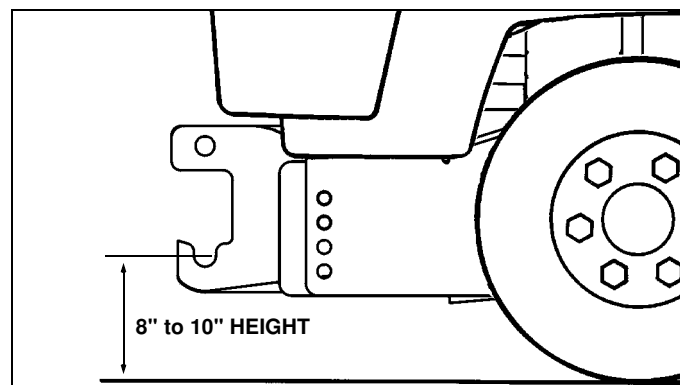

Figure 4

9. Repeat steps 5-8 for installing the Passenger Side Mount Weldment. Step 6 will require a hole to be center punched and drilled to 17/32" to insert the hardware.
10. Attach the Vehicle Center Member (#1) to the Driver and Passenger Side Mount Weldments (#2 & 3). Secure using (8) 1/2"-13 x 1-1/2" Cap Screws (#7), (2) 1/2" Lock Washers (#5), and (6) 1/2"-13 Locknuts (#10).
11. With all the components now in place, tighten all the hardware. Using the Torque Specification Chart below, torque all Cap Screws.

IMPORTANT: Height from the center of the lower Plow mounting holes on the Vehicle Mount Kit to the ground should be between 8" and 10" to insure proper operation.



| TORQUE SPECIFICATIONS FOR STANDARD MACHINE HARDWARE | | | | | |
|---|----------|----------|----------|-------------|------------|
| Bolt Size | GR.2 Dry | GR.5 Dry | GR.8 Dry | Metric Size | GR.8.8 Dry |
| 1/4" | 66* | 9 | 12 | M8 | 17 |
| 5/16" | 11 | 17 | 25 | M10 | 35 |
| 3/8" | 20 | 30 | 45 | M12 | 60 |
| 7/16" | 32 | 50 | 70 | M14 | 95 |
| 1/2" | 50 | 75 | 110 | M16 | 155 |
| 9/16" | 70 | 110 | 150 | | |
| 5/8" | 100 | 150 | 220 | | |
| 3/4" | 175 | 260 | 380 | | |
| 7/8" | 170 | 430 | 600 | | |
| 1" | 250 | 640 | 900 | | |

Note: These torque values are to be used for all hardware. Unless otherwise specified, all torque values must meet this specification.
 Note: All torque values are in Ft.-Lbs unless otherwise stated
 Note: *In-Lbs

REMEMBER After 5 to 10 hours of snowplow usage, re-torque all Cap Screws!

NOTE: The splash guard will need modifications if it is to be reinstalled with the vehicle mount kit attached. The Cable Ties (#11) can be used to hold the splash guard in place by drilling a hole in the splash guard and inserting it through the hole in the Side Mount Weldments (#2 & 3) and the splash guard.

12. Reinstall the bumper. The lower part of the bumper and valance will need to be cut (notched) to achieve the Vehicle Mount Kit height requirement.

PARTS LIST

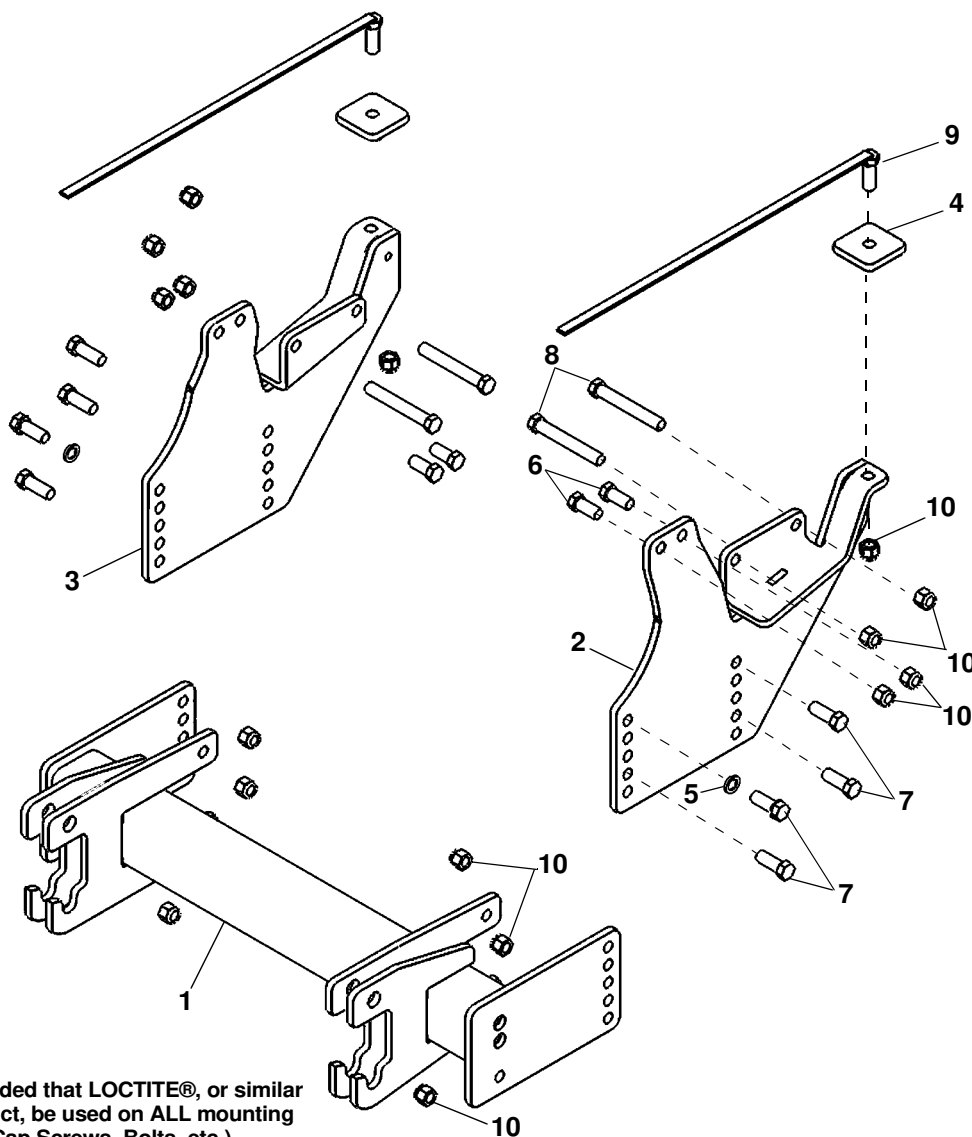

Note: It is recommended that LOCTITE®, or similar thread locking product, be used on ALL mounting hardware (i.e. Nuts, Cap Screws, Bolts, etc.).

| ITEM | PART NO. | DESCRIPTION | QTY. |
|------|----------|---|------|
| 1 | 99100890 | Vehicle Center Member | 1 |
| 2 | | Mount Weldment, DS | 1 |
| 3 | | Mount Weldment, PS | 1 |
| 4 | | Plate, Bearing | 2 |
| 5 | | LW, 1/2" | 2 |
| 6 | | HHCS, 1/2"-13 x 1-1/4" | 4 |
| 7 | | HHCS, 1/2"-13 x 1-1/2" | 8 |
| 8 | | HHCS, 1/2"-13 x 4" | 4 |
| 9 | | Handle Bolt Weldment, 1/2"-13 x 1-1/2 x 20" | 2 |
| 10 | | LN, 1/2"-13 | 16 |
| 11 | | Cable Tie (Not Shown) | 2 |
| 12 | 96117062 | Kit, HDWE (Includes Items 4-11) (Not Shown) | 1 |

SNO-WAY® INTERNATIONAL, INC.



Hartford, WI 53027 USA
 Website: www.snoway.com
 ©2018 Sno-Way® International