

SNO-WAY®

SNOW & ICE CONTROL EQUIPMENT

ASSEMBLY & INSTALLATION INSTRUCTIONS

**VEHICLE MOUNT KIT 99101314
FOR UTV SERIES PLOWS**

TO FIT
2018 - LATER POLARIS RANGER 1000

Sno-Way®; Down Pressure® and EIS® are registered trademarks of Sno-Way International, Inc.
ProControl™, MegaBlade™, V-Wing™, E-Z Switch™, Revolution™, MaxAdjust™, SpeedLock™, and
QuickJack™ are trademarks of Sno-Way International, Inc.

©2018 Sno-Way® International

97102117A



1. **THINK SAFETY, ALWAYS WEAR SAFETY GLASSES WHEN PERFORMING THE OPERATIONS PRESCRIBED IN THESE INSTRUCTIONS**
2. **READ ALL INSTRUCTIONS CAREFULLY BEFORE ATTEMPTING INSTALLATION**
3. **BEFORE BEGINNING WORK MAKE SURE TO SET PARKING BRAKE AND CHOCK WHEELS**



MINIMUM VEHICLE RECOMMENDATIONS

Heavy Duty Alternator Heavy Duty Battery

NOTE: On some vehicles it may be necessary to use a form of load booster to decrease the vehicle's front suspension sag with the snow plow in place. This can be accomplished with the use of supplementary air bags, booster springs, or similar load boosting devices. Since there are different load boosting devices available, it will up to the customer/end user to decide and purchase the product to suit the application, and not the responsibility of Sno-Way International, Inc.

INSTALLATION NOTES

1. **Unless otherwise specified, mount all Vehicle Mount Kit components to vehicle before tightening any hardware.**
2. **It is recommended that LOCTITE®, or similar thread locking product, be used on ALL mounting hardware (i.e. Nuts, Cap Screws, Bolts, etc.).**
3. Vehicle should be parked on a level surface with a normal vehicle load on the FRONT suspension.
4. Items in parentheses () refer to quantity required for this step. Items in parentheses with a pound sign (#) indicate the part number as found in the parts list on the last page of this document.
Example: (10) Washer, Lock, 1/2" (#8).
5. It maybe necessary to relocate license plate holder. Check state and local laws for placement, if needed.

ASSEMBLY TOOLS NEEDED

Impact Sockets	5/16" – 3/4"
	5mm – 16mm
Wrenches	5/16" – 3/4"
	5mm – 16mm
Torque Wrench	
Tape Measure	

MOUNTING INSTRUCTIONS

1. Remove (2) lower Cap Screws that hold the Bumper/Brush Guard to the frame (See Figure 1).



Figure 1

2. Behind the Brush Guard are four square holes in the frame. The bottom two square holes align with the top holes in the Top Weldment (#3) (See Figure 2).

NOTE: It may be necessary to loosen (but not remove) the top two Cap Screws that hold the Bumper/Brush Guard to the frame to be able to easily insert the Top Weldment (#3) behind the Bumper/Brush Guard.

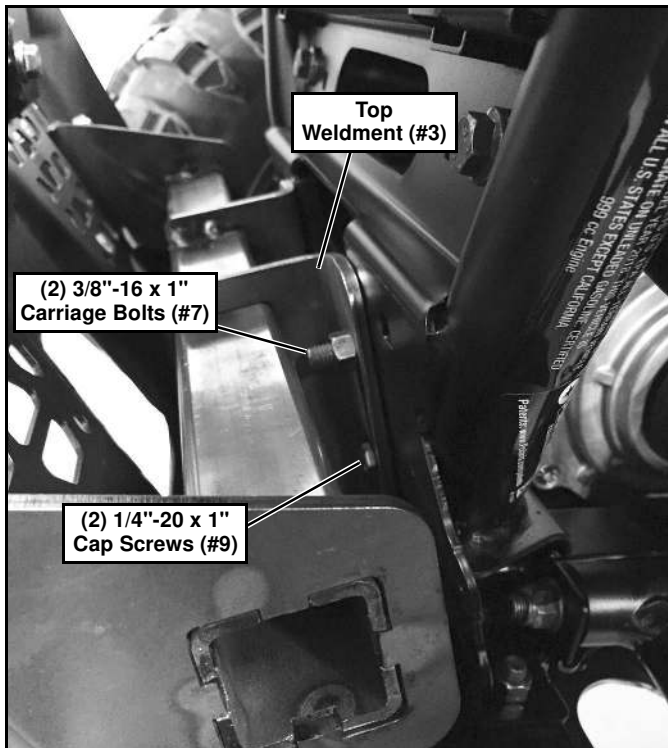

Figure 2

3. Insert (2) 3/8"-16 x 1" Carriage Bolts (#7) into the square holes on the vehicle frame and through the Top Weldment (#3). Secure with (2) 3/8"-16 Locknuts (#8). Insert (2) 1/4"-20 x 1" Cap Screws (#9) into the lower rear holes in the Top Weldment (#3) and through the frame. Secure with (2) 1/4"-20 Locknuts (#10) (See Figure 2).
4. Align the four bottom holes in the Bottom Weldment (#2) with the four holes in the bottom of the vehicle frame. The front two bottom holes align with the holes that the hardware was removed from in step 1 (See Figure 3).

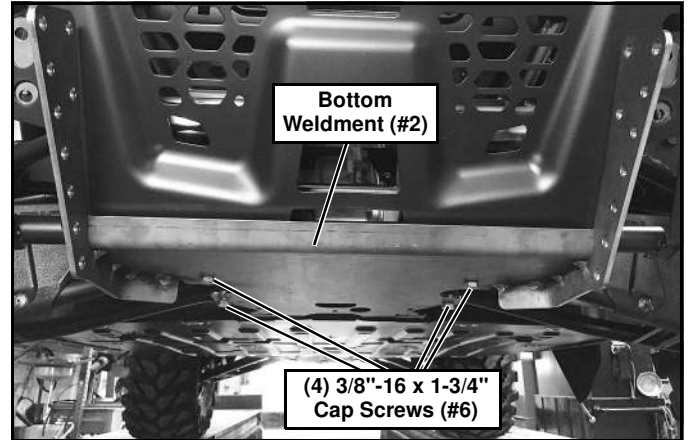

Figure 3

5. Insert (4) 3/8"-16 x 1-3/4" Cap Screws (#6) into the Bottom Weldment (#2) and into the vehicle frame. Secure with (4) 3/8"-16 Locknuts (#8) (See Figure 3).
6. On the driver's side, align the holes in the long leg of the Middle Bracket (#4) with the front holes of the Top Weldment (#3). The holes on the short leg align with the holes on the side of the Bottom Weldment (#2) (See Figure 4).

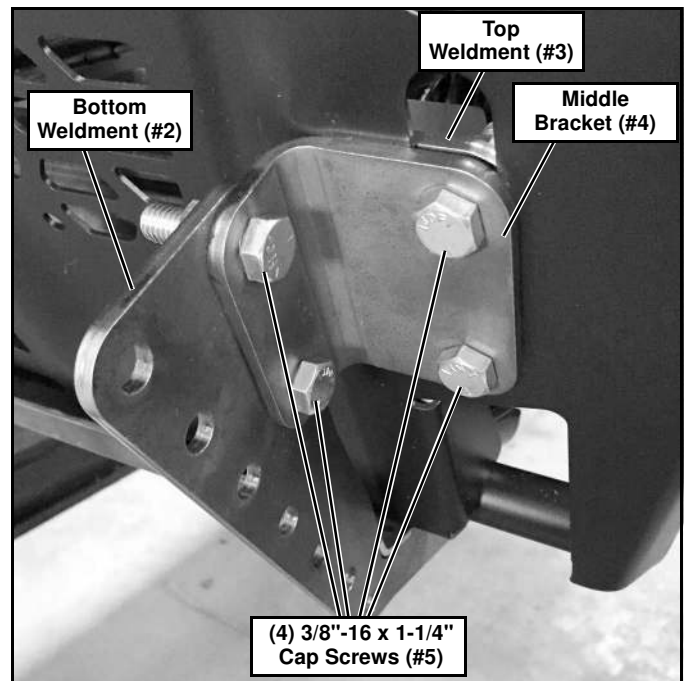

Figure 4

7. Insert (4) 3/8" -16 x 1-1/4" Cap Screws (#5) into the Middle Bracket (#4) and through the Bottom and Top Weldments (#2 & #3). Secure with (4) 3/8"-16 Locknuts (#8) (See Figure 4).
8. Repeat steps 6 & 7 on the Passengers Side (See Figure 5).

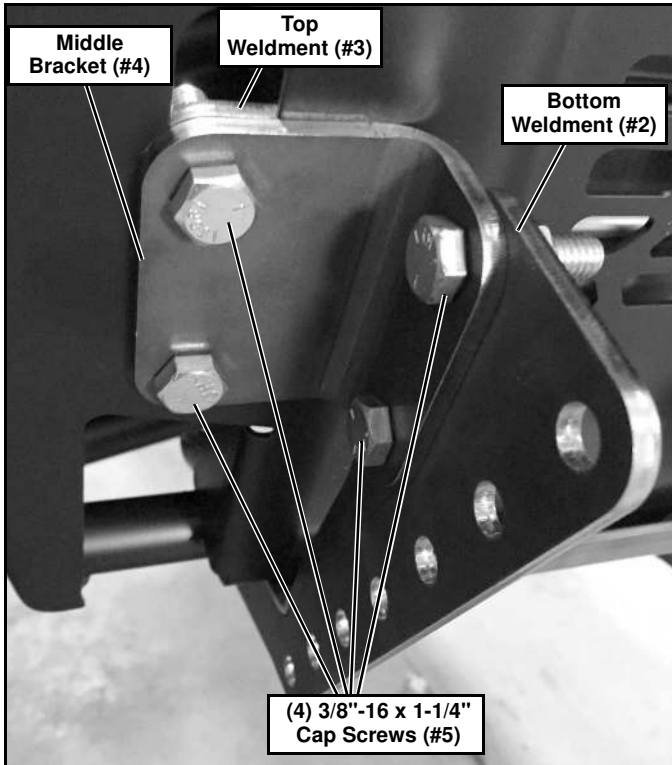

Figure 5

9. Align the UTV Mount (#1) with the front side holes in the Bottom Weldment (#2). Adjust the UTV Mount (#1) so that the center of the bottom slot is 11"-12" off of the ground (See Figure 6).

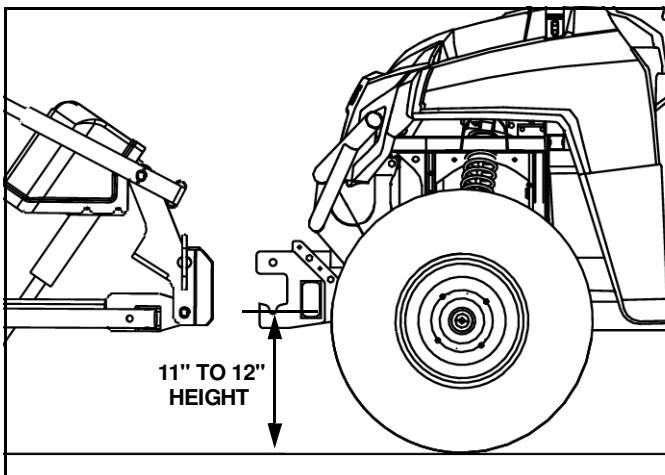

Figure 6

10. Insert (6) 3/8"-16 x 1-1/4" Cap Screws (#5) into the UTV Mount (#1) and through the Bottom Weldment (#2). Secure with (6) 3/8"-16 Locknuts (#8) (See Figure 7).

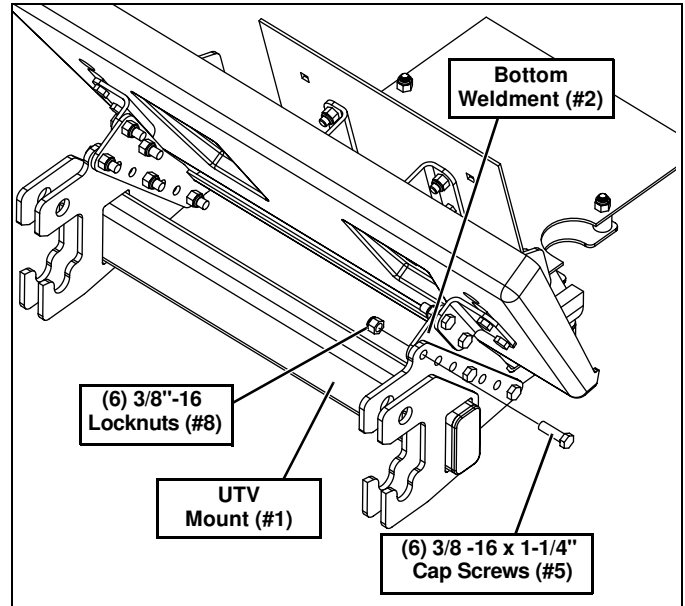

Figure 7

11. Tighten all hardware using the Torque Specification Chart below.

TORQUE SPECIFICATIONS FOR STANDARD MACHINE HARDWARE					
Bolt Size	GR.2 Dry	GR.5 Dry	GR.8 Dry	Metric Size	GR.8.8 Dry
1/4"	66*	9	12	M8	17
5/16"	11	17	25	M10	35
3/8"	20	30	45	M12	60
7/16"	32	50	70	M14	95
1/2"	50	75	110	M16	155
9/16"	70	110	150		
5/8"	100	150	220		
3/4"	175	260	380		
7/8"	170	430	600		
1"	250	640	900		

Note: These torque values are to be used for all hardware. Unless otherwise specified, all torque values must meet this specification.
 Note: All torque values are in Ft.-Lbs unless otherwise stated
 Note: *In-Lbs

NOTE: After 5 to 10 hours of snowplow usage, re-torque all Cap Screws!

PARTS LIST

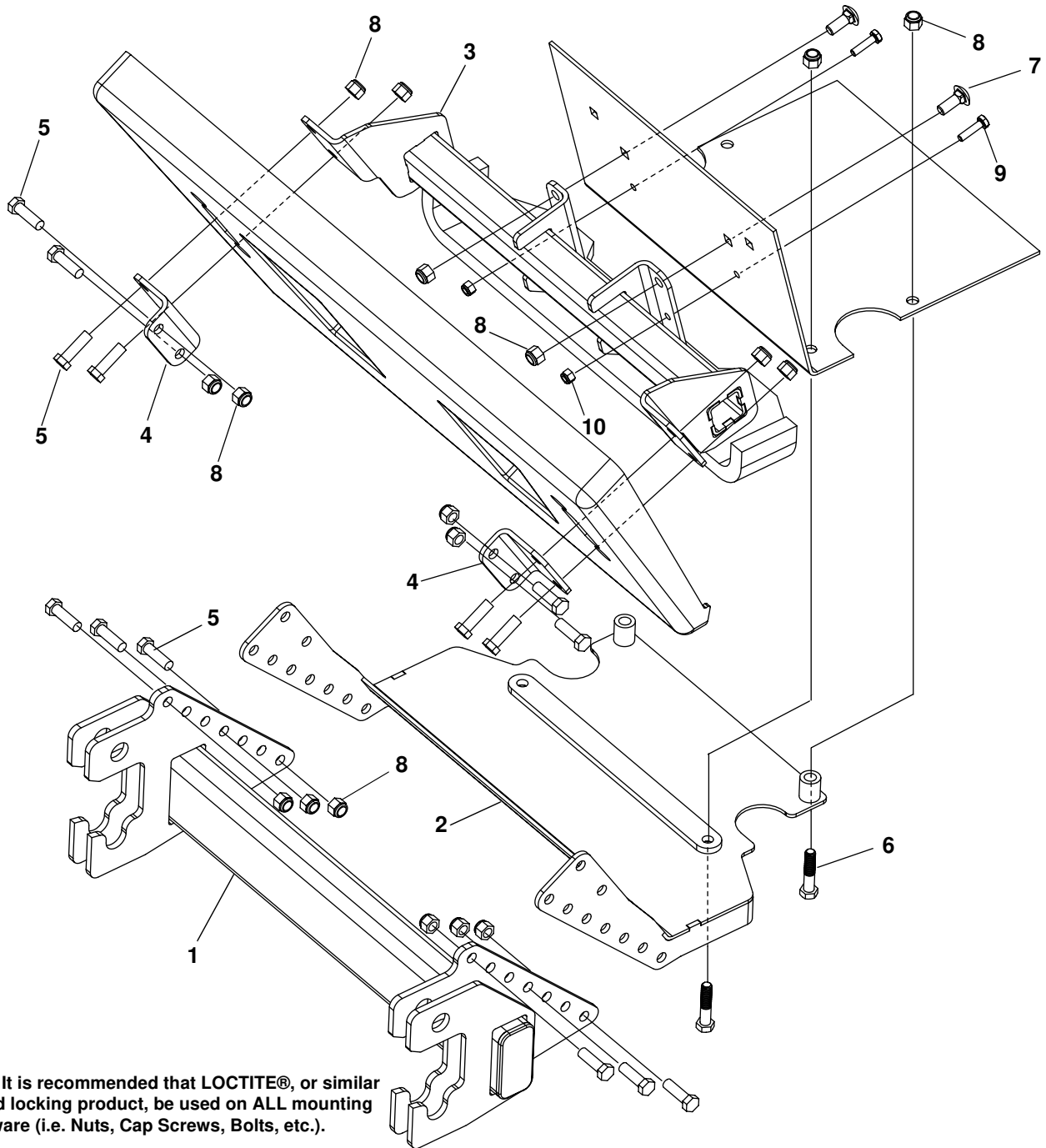

Note: It is recommended that LOCTITE®, or similar thread locking product, be used on ALL mounting hardware (i.e. Nuts, Cap Screws, Bolts, etc.).

ITEM	PART NO.	DESCRIPTION	QTY.
1		UTV Mount	1
2		Weldment, Bottom	1
3		Weldment, Top.....	1
4		Bracket, Middle.....	2
5		HHCS, 3/8"-16 x 1-1/4".....	14
6		HHCS, 3/8"-16 x 1-3/4".....	4
7		CB, 3/8"-16 x 1"	2
8		LN, 3/8"-16	20
9		HHCS, 1/4"-20 x 1".....	2
10		LN, 1/4"-20	2
11	96116750	Kit, HDWE (Includes items 5-10) (Not Shown).....	1

NOTES

NOTES

SNO-WAY® INTERNATIONAL, INC.



Hartford, WI 53027 USA
Website: www.snoway.com
©2018 Sno-Way® International

www.storksplows.com