

SNO-WAY®

SNOW & ICE CONTROL EQUIPMENT

ASSEMBLY & INSTALLATION INSTRUCTIONS

**SUBFRAME 99101330
FOR 22 PLOW SERIES ONLY
(Includes Vehicle Center Member)**

**TO FIT
2018 & LATER JEEP WRANGLER JL (4X4)**

Sno-Way®· Down Pressure® and EIS® are registered trademarks of Sno-Way International, Inc.
ProControl™, MegaBlade™, V-Wing™, E-Z Switch™, Revolution™, MaxAdjust™, SpeedLock™, and
QuickJack™ are trademarks of Sno-Way International, Inc.

©2018 Sno-Way® International

97102131A



1. **THINK SAFETY, ALWAYS WEAR SAFETY GLASSES WHEN PERFORMING THE OPERATIONS PRESCRIBED IN THESE INSTRUCTIONS**
2. **READ ALL INSTRUCTIONS CAREFULLY BEFORE ATTEMPTING INSTALLATION**
3. **BEFORE BEGINNING WORK MAKE SURE TO SET PARKING BRAKE AND CHOCK WHEELS**



MINIMUM VEHICLE RECOMMENDATIONS

Heavy Duty Alternator
 Heavy Duty Battery
 Manufacturers Snowplow Package

ASSEMBLY TOOLS NEEDED

Drill Bits	17/32"
Impact Sockets	3/4"
	7mm – 24mm
Wrenches	3/4"
	7mm – 24mm
Torque Wrench	
Rat Tail Pry Bar	
Cut Off Wheel	

NOTE: On some vehicles it may be necessary to use a form of load booster to decrease the vehicle's front suspension sag with the snow plow in place. This can be accomplished with the use of supplementary air bags, booster springs, or similar load boosting devices. Since there are different load boosting devices available, it will up to the customer/end user to decide and purchase the product to suit the application, and not the responsibility of Sno-Way International,

INSTALLATION NOTES

1. **Unless otherwise specified, mount all Vehicle Mount Kit Components to vehicle before tightening any hardware.**
2. It is recommended that LOCTITE®, or similar thread locking product, be used on ALL mounting hardware (i.e. Nuts, Cap Screws, Bolts, etc.).
3. Vehicle should be parked on a level surface with a normal vehicle load on the FRONT suspension.
4. Items in parentheses () refer to quantity required for this step. Items in parentheses with a pound sign (#) indicate the part number as found in the parts list on the last page of this document.
 Example: (10) Washer, Lock, 1/2" (#8).
5. It maybe necessary to relocate license plate holder. Check state and local laws for placement, if needed.

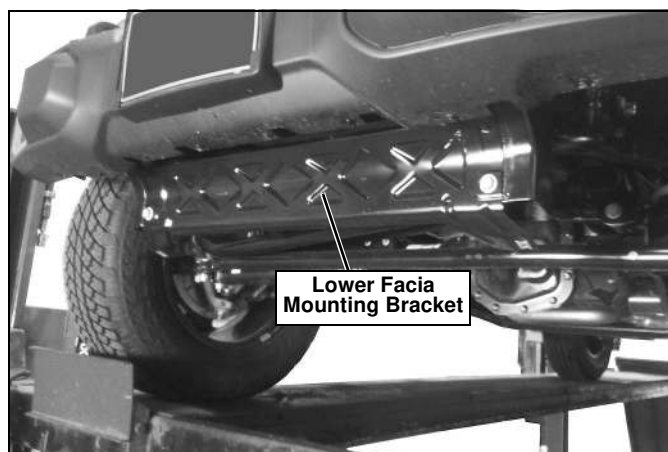

Figure 2

MOUNTING INSTRUCTIONS

1. Remove the lower facia (See Figure 1), the lower facia mounting bracket (See Figure 2), bumper (See Figure 3), and outside bumper brackets (See Figure 4). Retain hardware for re-installation.

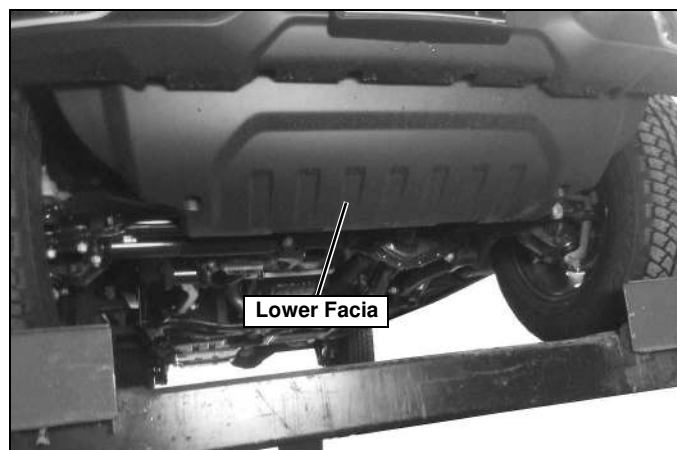

Figure 1



Figure 3

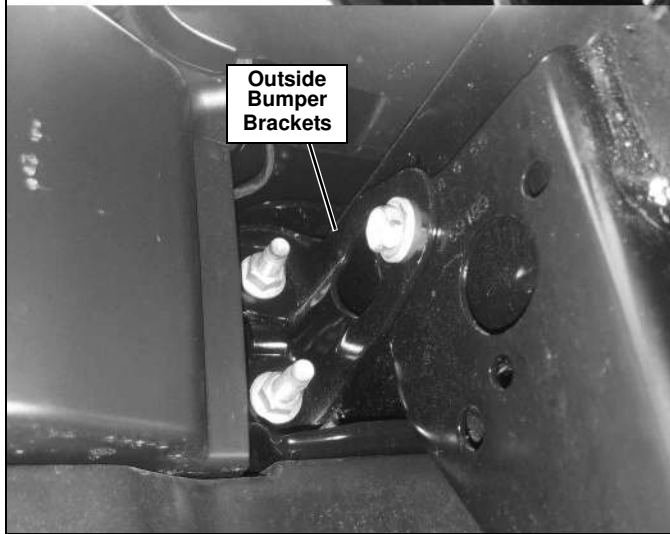
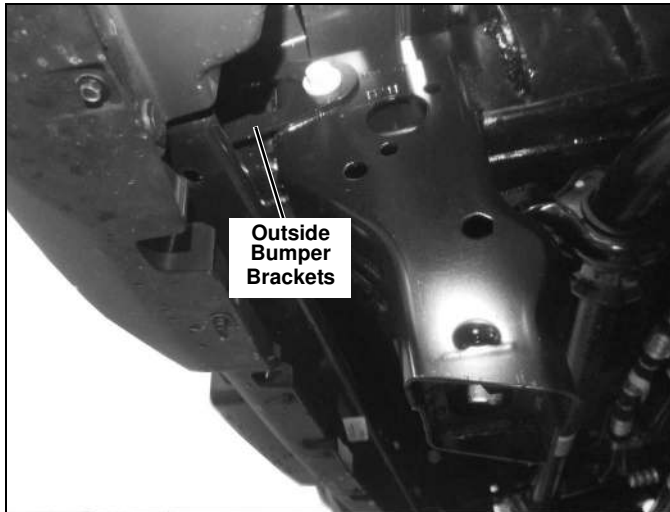

Figure 4

2. Mount the Driver's Side Mounting Bracket (#2) to the frame by aligning the holes and placing it in the same position that the driver side bumper bracket was removed. In the same location the OEM M10 bolt came from (See Figure 5), use a 1/2" Lock Washer (#5) and M10-1.5 x 35mm, Cap Screw (#7) to secure Driver's Side Mounting Bracket (#2) to the frame. (See Figure 6.)

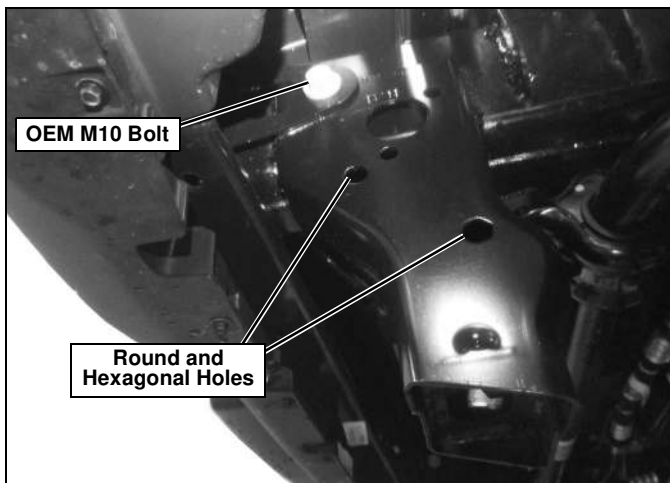

Figure 5

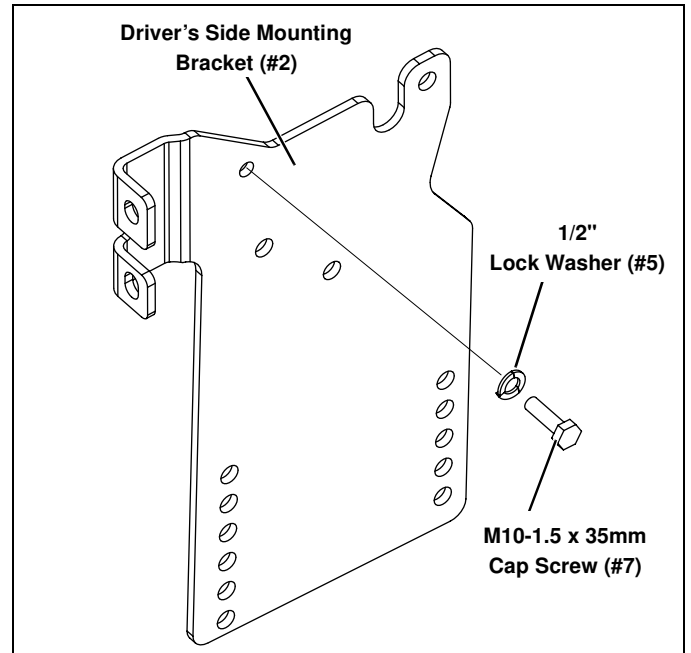

Figure 6

3. Insert (2) 1/2"-13 x 1-1/2" Cap Screws (#6) through Driver's Side Mounting Bracket (#2) and into the round and hexagonal holes of the frame. Secure with (2) 1/2"-13 Locknuts (#9). (See Figure 5 and Figure 7.)

NOTE: Placing a locknut inside the closed end of a combination wrench and taping the back side will help hold the nut to the wrench and help reach inside the frame.

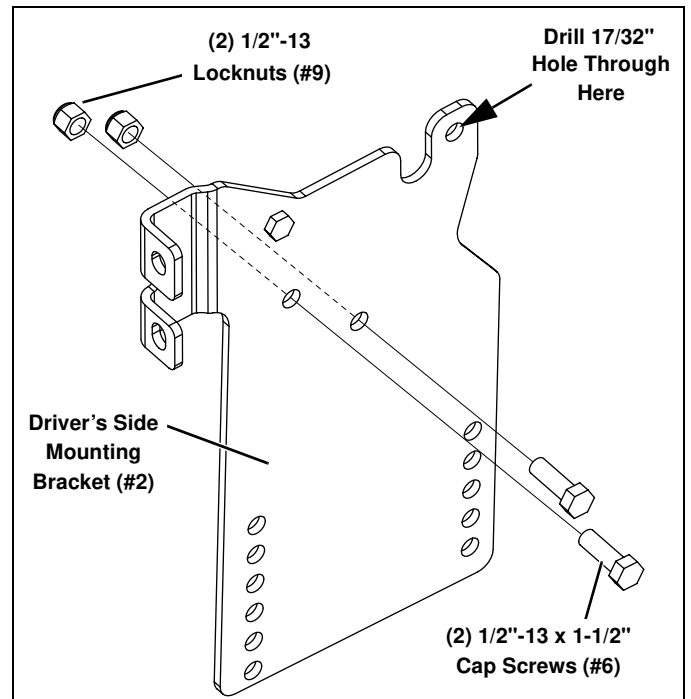

Figure 7

4. Clamp the Driver Side Mounting Bracket (#2) to the front and side of the frame rail. Use the upper rear hole as a template to center punch and drill a 17/32" hole in the side of the frame. (See Figure 7.)

5. Align a Spacer Plate (#4) with the drilled hole, but between item #2 and the frame. Insert a 1/2"-13 x 2" Handle Bolt Weldment (#8) through the front of the vehicle frame, through the drilled hole, Spacer Plate (#4), and Driver's Side Mounting Bracket (#2). Secure with a 1/2"-13 Locknut (#9). Remove clamps and cut off any of the handle of item #8 sticking out the front of the frame rail. (See Figure 8.)

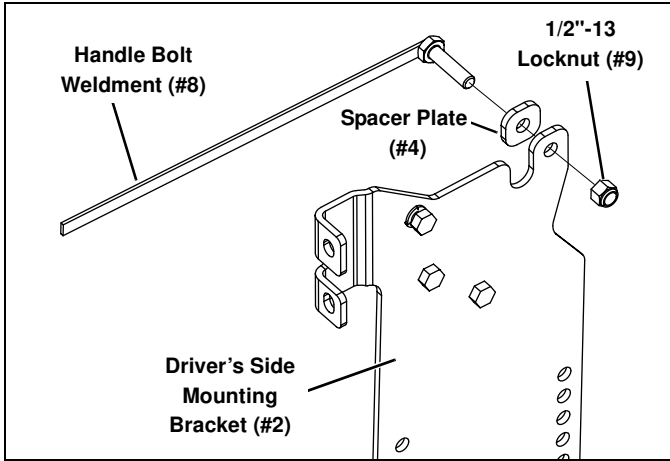

Figure 8

6. Repeat steps 2-5 for attaching the Passenger Side Mounting Bracket (#3).
 7. Position the Vehicle Center Member (#1) between the Side Mounting Brackets (#2 and #3) to allow for an 8" to 10" height between the VCM and the ground. (See Figure 9.)

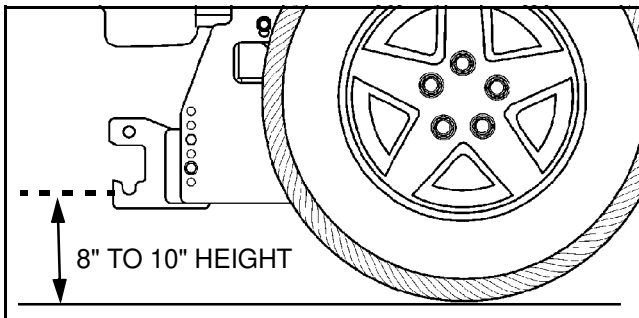

Figure 9

IMPORTANT: Height from the center of the lower Plow Mounting slots on the Vehicle Center Member to the ground should be between 8" and 10" to ensure proper operation.

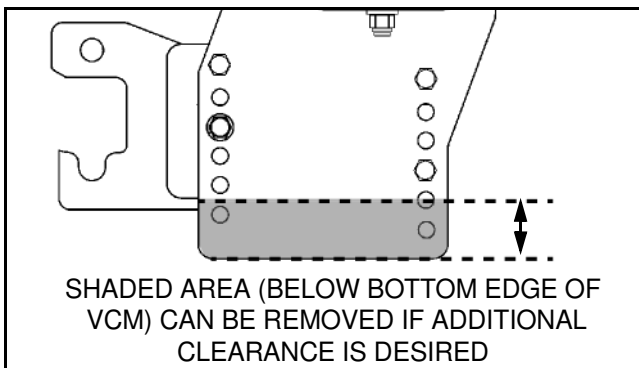

Figure 10

NOTE: Due to the various combinations of tires sizes and suspension components used on these vehicles, the Side Weldments (#2 & #3) have been manufactured to handle a wide range of vehicle ride heights. If the Vehicle Center Member is mounted similar to Figure 10 to achieve the required 8" to 10" clearance, the shaded portion of both Side Weldments (below the bottom edges of the Vehicle Center Member) can be cut off and the exposed metal dressed with touch-up paint.

8. Secure the Vehicle Center Member using (8) 1/2"-13 x 1-1/2" Caps Screws (#6), (2) 1/2" Lock Washers (#5) and (6) 1/2"-13 Locknuts (#9). (See Figure 11.)

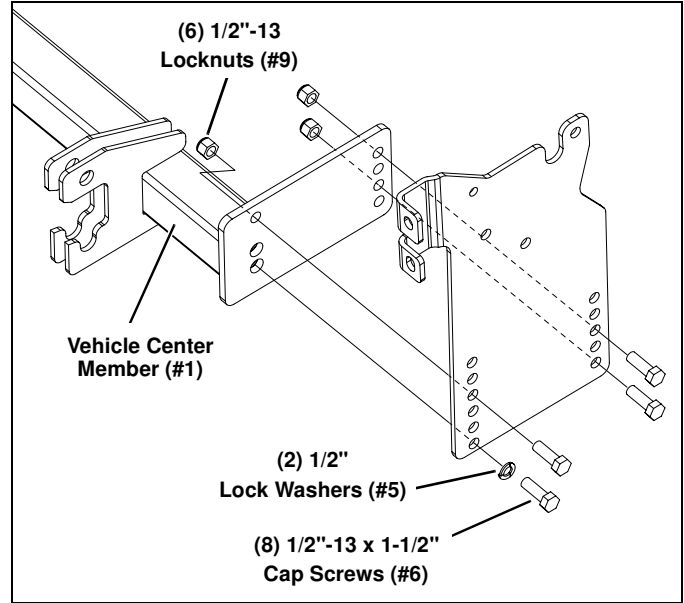

Figure 11

9. Mount the bumper back onto the vehicle. (The outside bumper brackets and M10 bolts will not be used.)
 10. Tighten all hardware using the torque specification chart provided below.
 11. Re-install the lower fascia mounting bracket and lower fascia. The lower fascia will need to be modified to fit around the Side Mounting Brackets.

TORQUE SPECIFICATIONS FOR STANDARD MACHINE HARDWARE

Bolt Size	GR.2 Dry	GR.5 Dry	GR.8 Dry	Metric Size	GR.8.8 Dry
1/4"	66*	9	12	M8	17
5/16"	11	17	25	M10	35
3/8"	20	30	45	M12	60
7/16"	32	50	70	M14	95
1/2"	50	75	110	M16	155
9/16"	70	110	150		
5/8"	100	150	220		
3/4"	175	260	380		
7/8"	170	430	600		
1"	250	640	900		

Note: These torque values are to be used for all hardware. Unless otherwise specified, all torque values must meet this specification.
 Note: All torque values are in Ft.-Lbs unless otherwise stated
 Note: *In-Lbs

REMEMBER After 5 to 10 hours of snowplow usage, re-torque all Cap Screws!

PARTS LIST

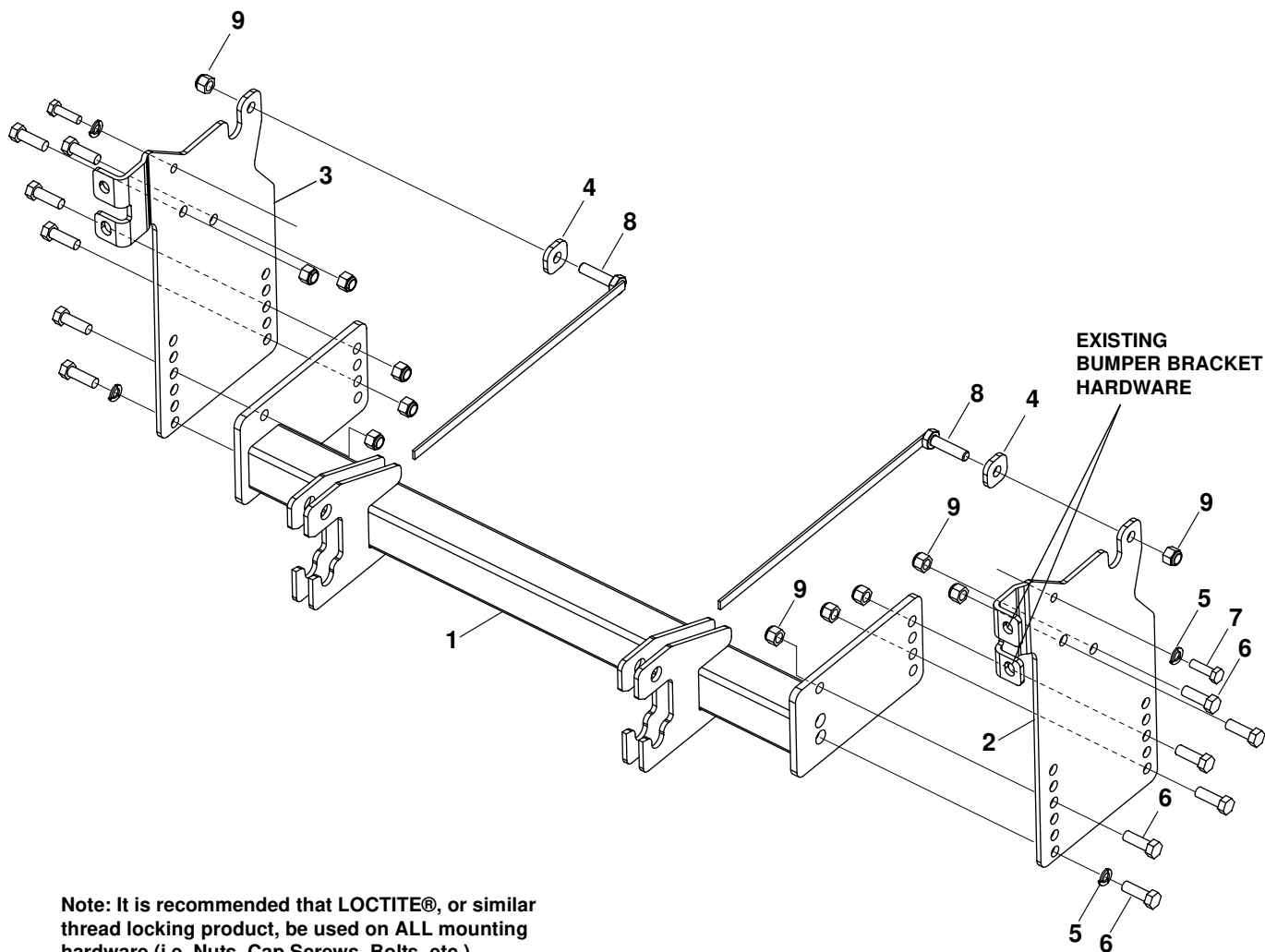

Note: It is recommended that LOCTITE®, or similar thread locking product, be used on ALL mounting hardware (i.e. Nuts, Cap Screws, Bolts, etc.).

ITEM	PART NO.	DESCRIPTION	QTY.
1		Vehicle Center Member	1
2		Bracket, Mounting, DS.....	1
3		Bracket, Mounting, PS.....	1
4		Plate, Spacer	2
5		LW, 1/2"	4
6		HHCS, 1/2"-13 x 1-1/2"	12
7		HHCS, M10-1.50 x 35mm	2
8		Weldment, Handle Bolt, 1/2"-13 x 2"	2
9		LN, 1/2".....	12
10	96116898	Kit, HDWE (Includes Items 4-9) (Not Shown)	1

NOTES

NOTES

SNO-WAY® INTERNATIONAL, INC.



Hartford, WI 53027 USA
Website: www.snoway.com
©2018 Sno-Way® International

www.storksplows.com