

# **SNO-WAY**®

**SNOW & ICE CONTROL EQUIPMENT**

## **ASSEMBLY & INSTALLATION INSTRUCTIONS**

**VEHICLE MOUNT KIT 99101331  
FOR UTV SERIES PLOW**

TO FIT  
2018 & Later - John Deere Gator XUV 835, 865



©2018 Sno-Way® International

97102127A



**1. THINK SAFETY, ALWAYS WEAR SAFETY GLASSES WHEN PERFORMING THE OPERATIONS PRESCRIBED IN THESE INSTRUCTIONS**

**2. READ ALL INSTRUCTIONS CAREFULLY BEFORE ATTEMPTING INSTALLATION**

**3. BEFORE BEGINNING WORK MAKE SURE TO SET PARKING BRAKE AND CHOCK WHEELS**



## ASSEMBLY TOOLS

Drill Bits	1/4" - 17/32"
Impact Sockets	7/16" - 1-3/8"
Wrenches	7/16" - 1-3/8"
Torque Wrench	
Rat Tail Pry Bar	
Center Punch and Hammer	
C-Clamp	
Screwdrivers	

## INSTALLATION NOTES

1. Vehicle should be parked on a level surface with a normal vehicle load on the FRONT suspension.

2. On some vehicles it may be necessary to raise or stiffen the suspension to decrease the vehicles front suspension sag with the snow plow in place.

3. Unless otherwise specified, mount all Vehicle Mount Kit Components to vehicle before tightening any hardware.

4. It is recommended that LOCTITE®, or similar thread locking product, be used on ALL mounting hardware (i.e. Nuts, Cap Screws, Bolts, etc.).

5. Items in parentheses () refer to quantity required for this step. Items in parentheses with a pound sign (#) indicate the part number as found in the parts list on the last page of this document.

Example: (2) 1/2" Lock Washers (#9).

## MOUNTING INSTRUCTIONS

1. Remove two front bolts, and two rear socket cap screws from bottom skid plate. (See Figure 1.)

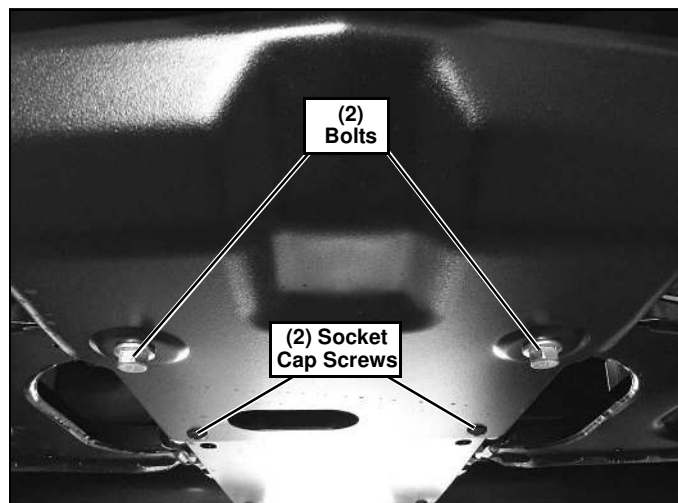

Figure 1

2. Position Bottom Weldment (#4) under bottom skid plate. Insert the original two Gator bolts and two socket cap screws previously removed. (See Figure 2.)

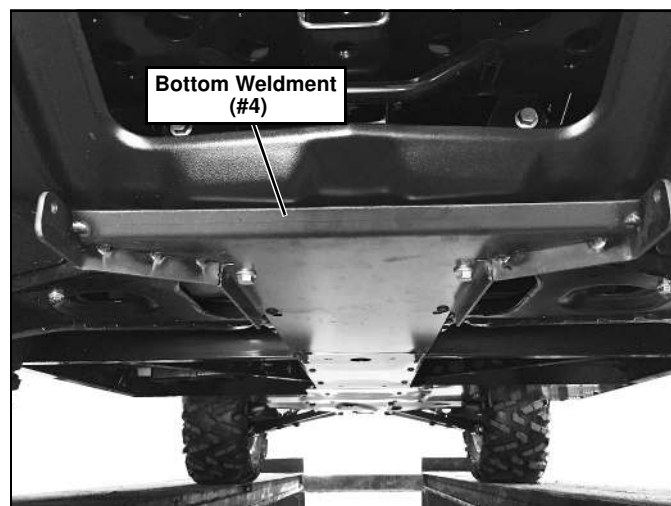

Figure 2

3. On the Driver's Side, position the Driver's Side Bracket Weldment (#3) on top of the UTV frame cross member. The top two holes in the Driver's Side Bracket Weldment (#3) should line up with holes in the frame cross member and the bottom side hole should line up with the side hole in the Bottom Weldment (#4). The Driver's Side Bracket (#3) should be to the inside of the Bottom Weldment (#4). (See Figure 3.)

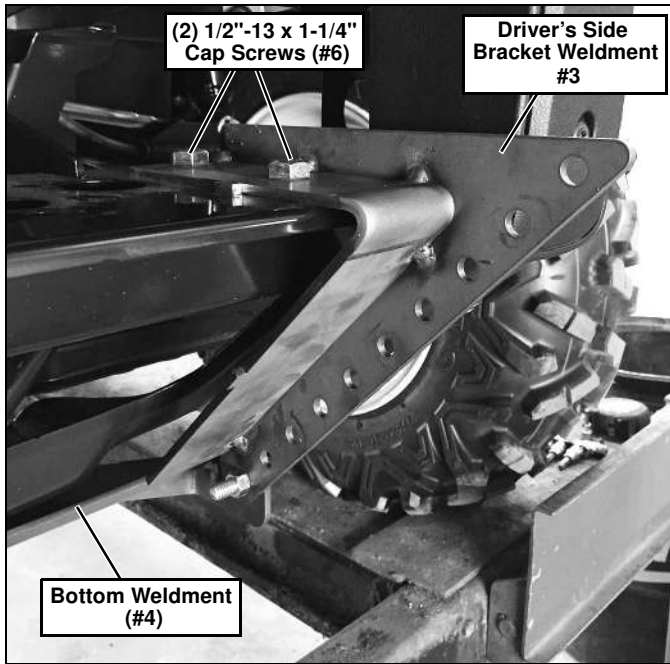

Figure 3

4. Insert (1) 3/8"-16 x 1-1/4" Cap Screw (#9) into the side hole of the Bottom Weldment (#4) and into the Driver's Side Bracket Weldment (#3). Secure with (1) 3/8"-16 Lock Nut (#10). (See Figure 4.)

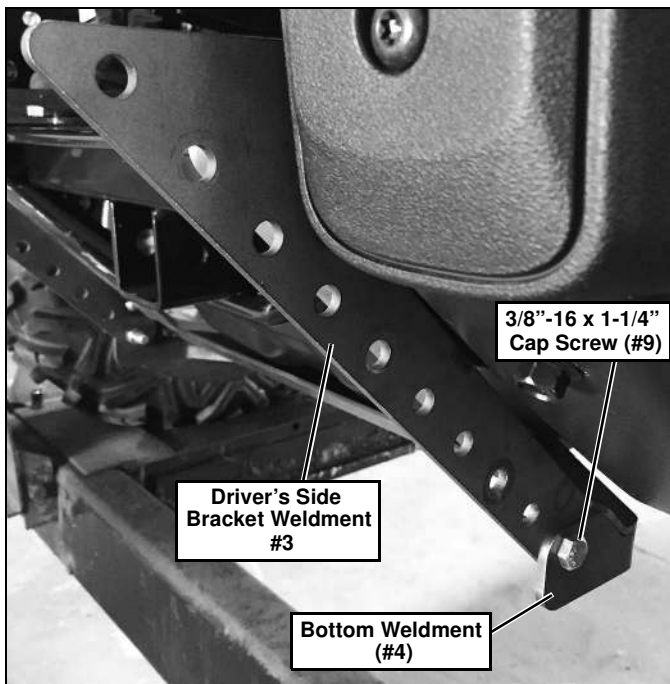

Figure 4

5. Insert (2) 1/2"-13 x 1-1/4" Cap Screws (#6) and (2) 1/2" Lock Washers (#5) into the top holes of the Driver's Side Bracket Weldment (#3) and thru the UTV frame. (See Figure 3.)

6. Secure the rear 1/2"-13 x 1-1/4" Cap Screw (#6) with (1) 1/2"-13 Hex Nut (#7). (See Figure 5.)

7. Secure the front 1/2"-13 x 1-1/4" Cap Screw (#6) with (1) 1/2"-13 Wire Nut (#8). (See Figure 5.)

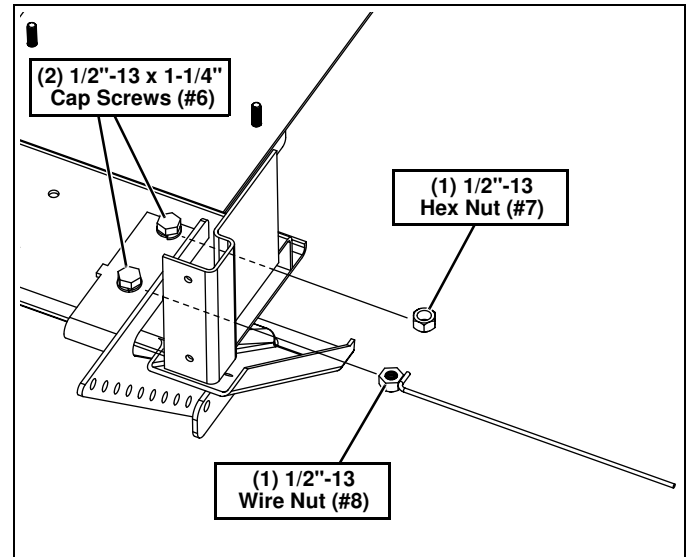

Figure 5

8. Using the Passenger's Side Bracket Weldment (#2), repeat steps 3-7 on the passenger's side. (See Figure 6.)

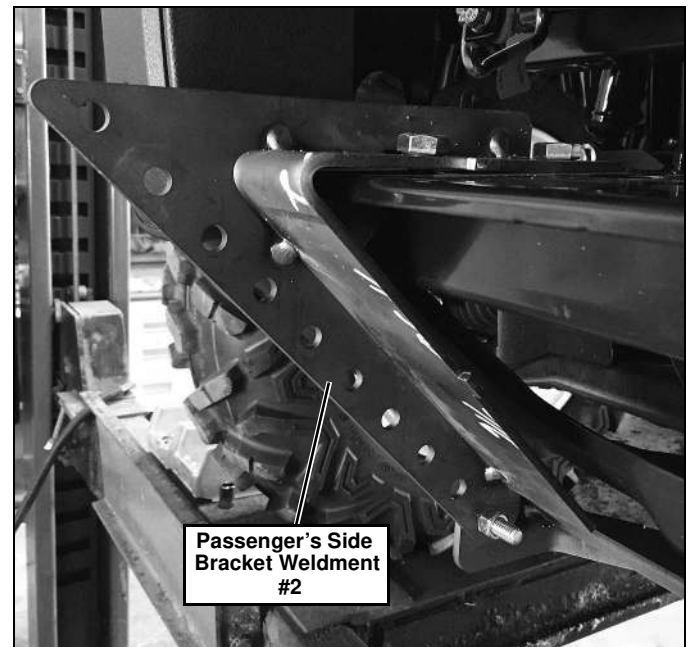

Figure 6

9. Position the UTV Mount (#1) on the machine. The UTV Mount (#1) should be to the inside of both Bracket Weldments (#2 and #3). (See Figure 7.)

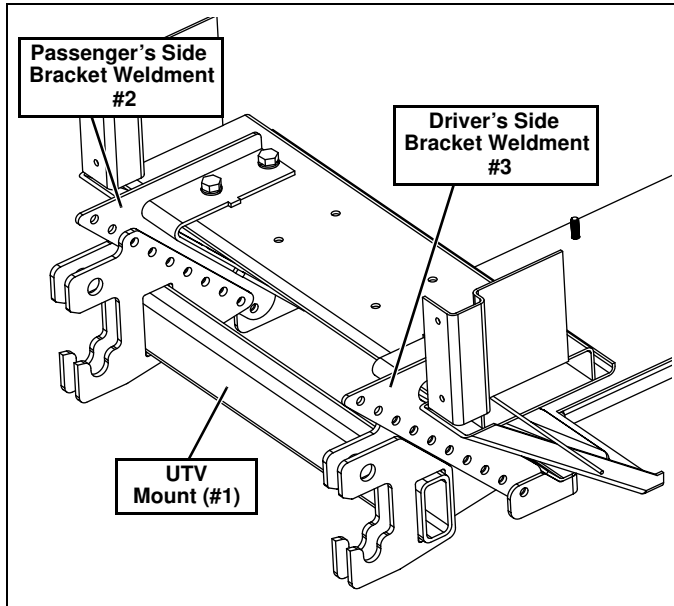

Figure 7

10. Align the mount holes with both Bracket Weldments (#2 & #3) to provide an 11" to 12" height between the lower pin slots and the ground. (See Figure 8.)

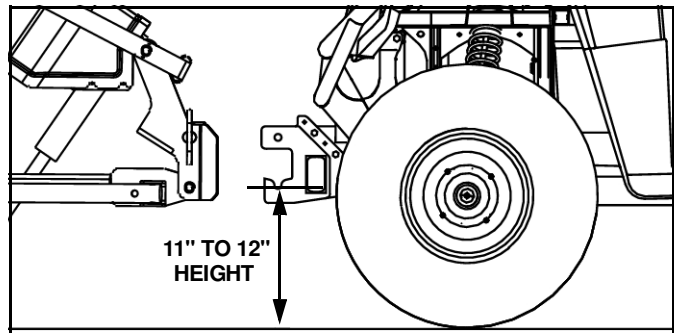

Figure 8

**IMPORTANT:** Height from the bottom of the lower pin slots on the UTV Mount to the ground should be between 11" and 12" to ensure proper operation.

11. Secure the UTV Mount (#1) to both Bracket Weldments (#2 and #3) using (6) 3/8"-16 x 1-1/4" Cap Screws (#9) and (6) 3/8"-16 Lock Nuts (#10). (See Figure 9.)

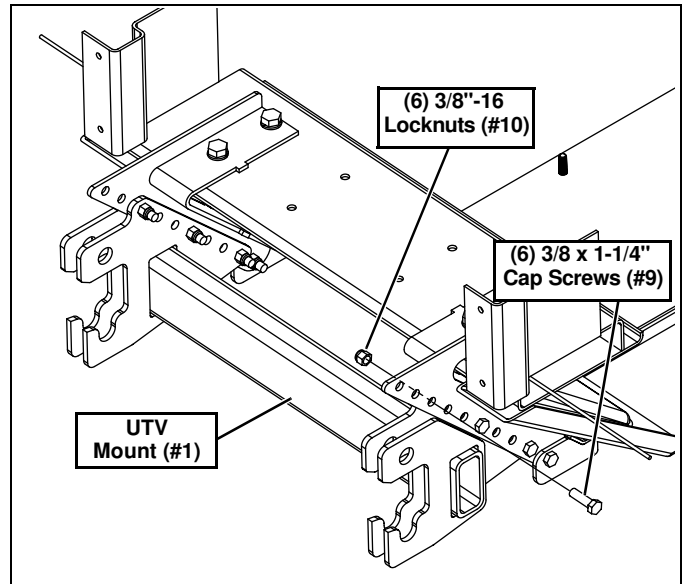

Figure 9

12. Tighten all hardware using the Torque Specification Chart provided:

TORQUE SPECIFICATIONS FOR STANDARD MACHINE HARDWARE					
Bolt Size	GR.2 Dry	GR.5 Dry	GR.8 Dry	Metric Size	GR.8.8 Dry
1/4"	66*	9	12	M8	17
5/16"	11	17	25	M10	35
3/8"	20	30	45	M12	60
7/16"	32	50	70	M14	95
1/2"	50	75	110	M16	155
9/16"	70	110	150		
5/8"	100	150	220		
3/4"	175	260	380		
7/8"	170	430	600		
1"	250	640	900		

These torque values are to be used for all hardware. Unless otherwise specified, all torque values must meet this specification. All torque values are in Ft.-Lbs unless otherwise stated \*In-Lbs

**REMEMBER** After 5 to 10 hours of snowplow usage, re-torque all hardware!

# PARTS LIST

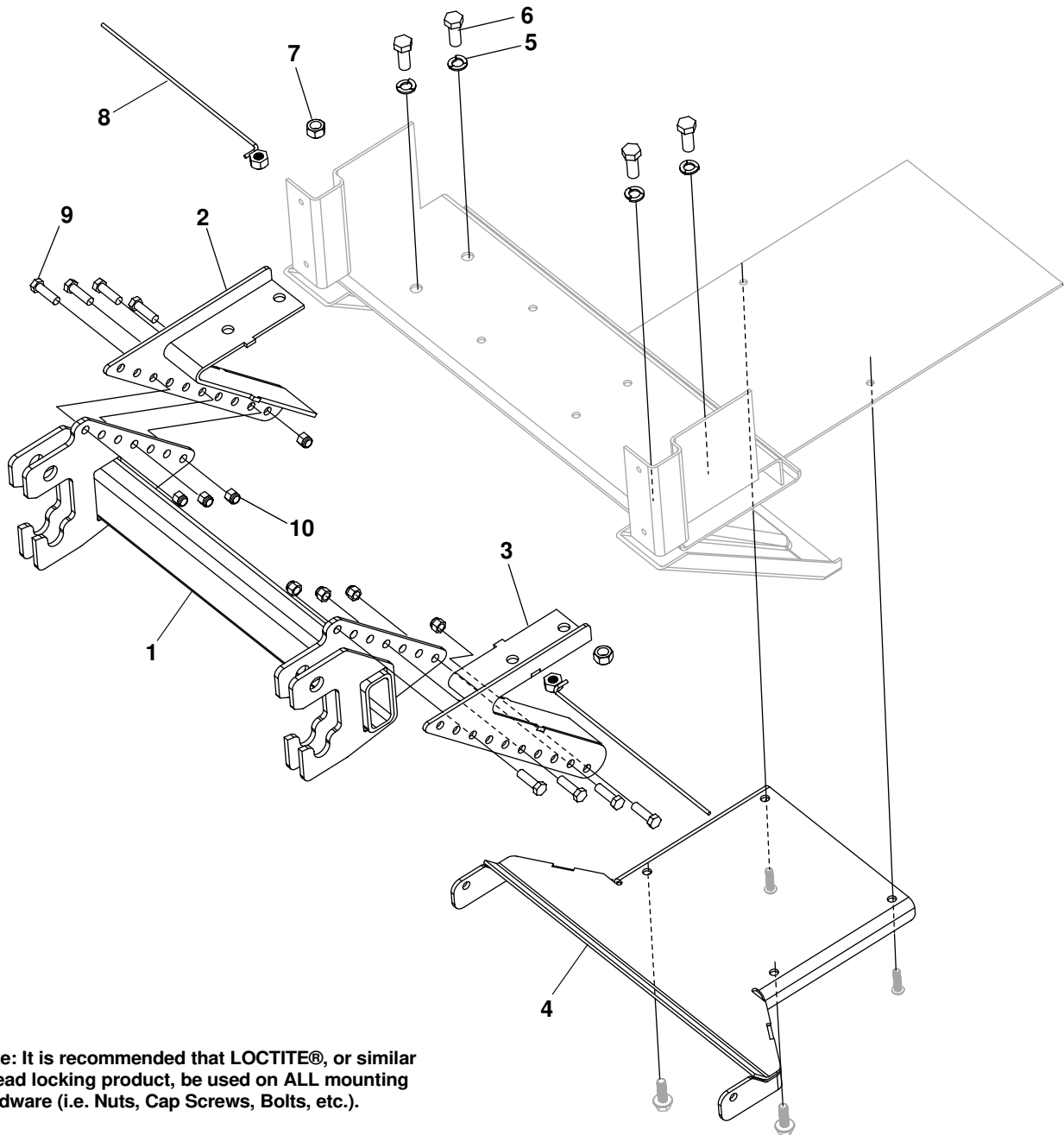

**Note:** It is recommended that LOCTITE®, or similar thread locking product, be used on ALL mounting hardware (i.e. Nuts, Cap Screws, Bolts, etc.).

ITEM	PART NO.	DESCRIPTION	QTY.
1		UTV Mount.....	1
2		Weldment, Bracket, Passenger's Side (XUV 835 Gator).....	1
3		Weldment, Bracket, Driver's Side (XUV 835 Gator) .....	1
4		Weldment, Bottom (XUV 835 Gator) .....	1
5		LW, 1/2".....	4
6		HHCS, 1/2"-13 x 1-1/4".....	4
7		HN, 1/2"-13.....	2
8		Wire Nut, 1/2"-13 .....	2
9		HHCS, 3/8"-16 x 1-1/4".....	8
10		LN, 3/8"-16.....	8
11	96116858	Kit, HDWE (Includes items 5-10) (Not Shown).....	1

# NOTES

# NOTES

---

**SNO-WAY® INTERNATIONAL, INC.**



Hartford, WI 53027 USA  
Website: [www.snoway.com](http://www.snoway.com)  
©2018 Sno-Way® International

[www.storksplows.com](http://www.storksplows.com)