

# **SNO-WAY**®

**SNOW & ICE CONTROL EQUIPMENT**

## **ASSEMBLY & INSTALLATION INSTRUCTIONS**

**VEHICLE MOUNT KIT 99101333  
FOR UTV SERIES PLOW**

TO FIT  
2018 & Later - Kioti K9



©2018 Sno-Way® International

97102142A



1. THINK SAFETY, ALWAYS WEAR SAFETY GLASSES WHEN PERFORMING THE OPERATIONS PRESCRIBED IN THESE INSTRUCTIONS
2. READ ALL INSTRUCTIONS CAREFULLY BEFORE ATTEMPTING INSTALLATION
3. BEFORE BEGINNING WORK MAKE SURE TO SET PARKING BRAKE AND CHOCK WHEELS



### ASSEMBLY TOOLS NEEDED

Impact Sockets	7/16" - 1-3/8"
Wrenches	7/16" - 1-3/8"
Drill Bit	13/32"
Torque Wrench	
Center Punch	

### INSTALLATION NOTES

1. Vehicle should be parked on a level surface with a normal vehicle load on the FRONT suspension.
2. On some vehicles it may be necessary to raise or stiffen the suspension to decrease the vehicles front suspension sag with the snow plow in place.
3. Unless otherwise specified, mount all Vehicle Mount Kit Components to vehicle before tightening any hardware.
4. It is recommended that LOCTITE®, or similar thread locking product, be used on ALL mounting hardware (i.e. Nuts, Cap Screws, Bolts, etc.).
5. Items in parentheses ( ) refer to quantity required for this step. Items in parentheses with a pound sign (#) indicate the part number as found in the parts list on the last page of this document.  
Example: (2) 1/2" Lock Washers (#9).

### MOUNTING INSTRUCTIONS

1. Remove the brush guard and inner shroud.  
(See Figure 1 and Figure 2.)

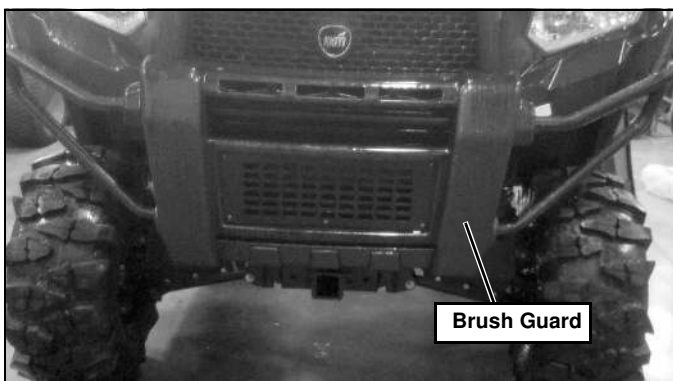

Figure 1

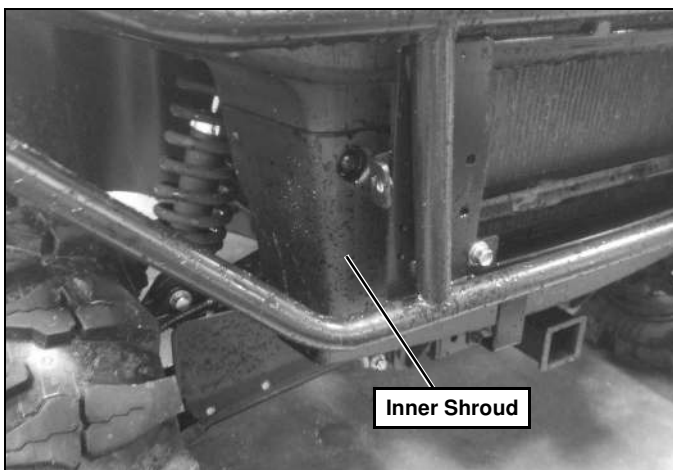

Figure 2

2. Remove the receiver hitch (if equipped).  
(See Figure 3.)

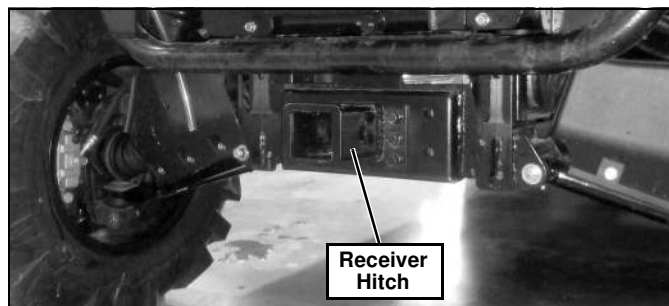

Figure 3

3. Align the rear four holes of the Mounting Weldment (#2) to the holes of the frame where the receiver hitch hardware was attached. Secure using (4) 3/8" Plain Washers (#6), (4) M10 Lock Washers (#7), and (4) M10-1.25 x 30 mm Cap Screws (#8). (See Figure 4.)

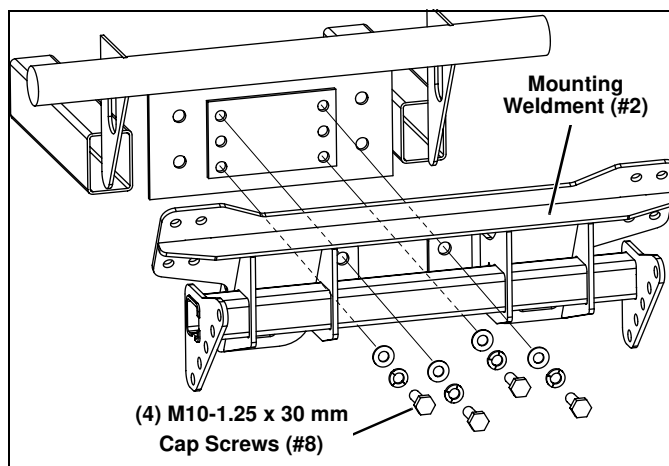

Figure 4

4. Attach the top of the Mounting Weldment (#2) to the tubular frame section with (4) 3/8"-16 x 1-3/4" x 2-3/4" U-Bolts (#5) and (8) 3/8"-16 Locknuts (#4). (See Figure 5.)

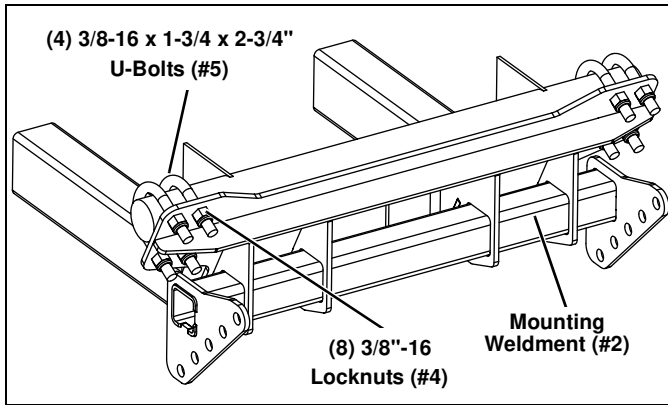

Figure 5

5. Tighten all installed hardware using the Torque Specification Chart.  
 6. Using the holes in both sides of the Mounting Weldment (#2) as a template, center punch and drill 13/32" holes into the vehicle's frame gusset. (See Figure 6.)

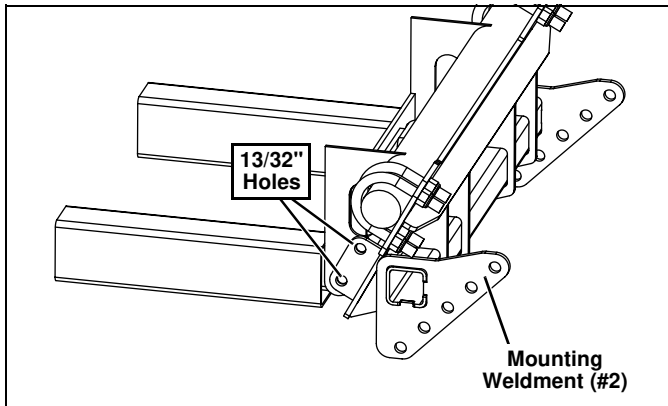

Figure 6

7. Attach the vehicle's frame gusset to the Mounting Weldment (#2) with (4) 3/8"-16 x 1" Cap Screws (#3) and (4) 3/8"-16 Locknuts (#4). Two on each side. (See Figure 7.)

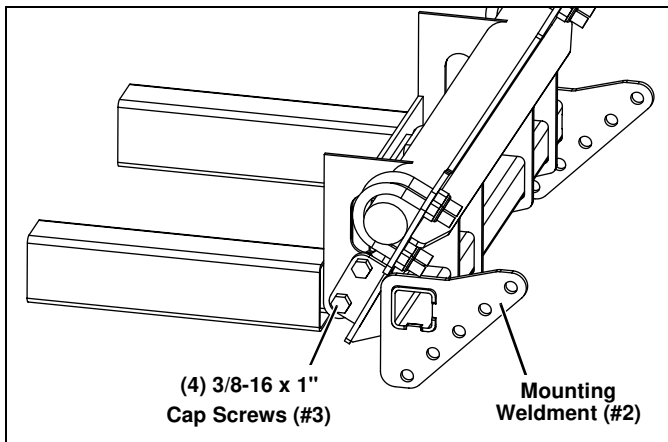

Figure 7

8. Attach the UTV Mount (#1) to the Mounting Weldment (#2) with (6) 3/8"-16 x 1" Cap Screws (#3) and (6) 3/8"-16 Locknuts (#4). Three on each side. (See Figure 8.)

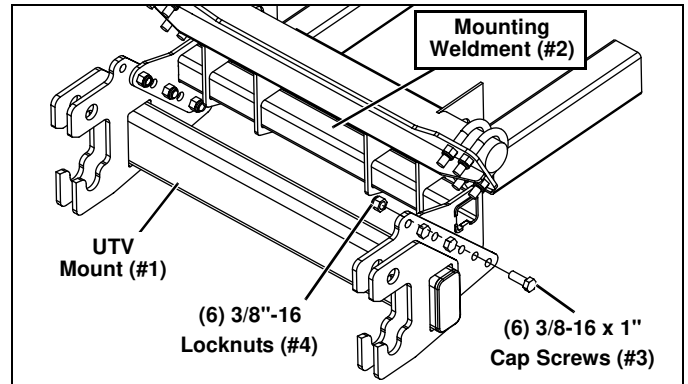
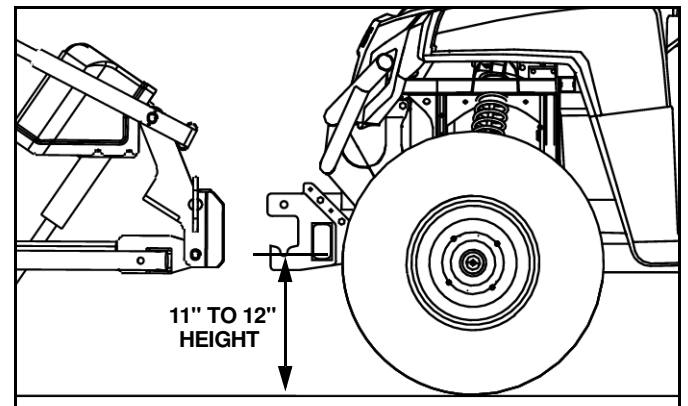

Figure 8

9. Adjust the UTV Mount (#1) so that the center of the bottom slot is 11-12" off the ground.



**IMPORTANT:** Height from the bottom of the lower pin slots on the UTV Mount to the ground should be between 11" and 12" to ensure proper operation.

10. Re-attach the brush guard to the vehicle. Keep the inner shroud and hardware for re-installation if mount is removed.  
 11. Tighten all hardware using the Torque Specification Chart below.

TORQUE SPECIFICATIONS FOR STANDARD MACHINE HARDWARE					
Bolt Size	GR.2 Dry	GR.5 Dry	GR.8 Dry	Metric Size	GR.8.8 Dry
1/4"	66*	9	12	M8	17
5/16"	11	17	25	M10	35
3/8"	20	30	45	M12	60
7/16"	32	50	70	M14	95
1/2"	50	75	110	M16	155
9/16"	70	110	150		
5/8"	100	150	220		
3/4"	175	260	380		
7/8"	170	430	600		
1"	250	640	900		

These torque values are to be used for all hardware. Unless otherwise specified, all torque values must meet this specification.  
 All torque values are in Ft.-Lbs unless otherwise stated  
 \*In-Lbs

**REMEMBER** After 5 to 10 hours of snowplow usage, re-torque all hardware!

# PARTS LIST

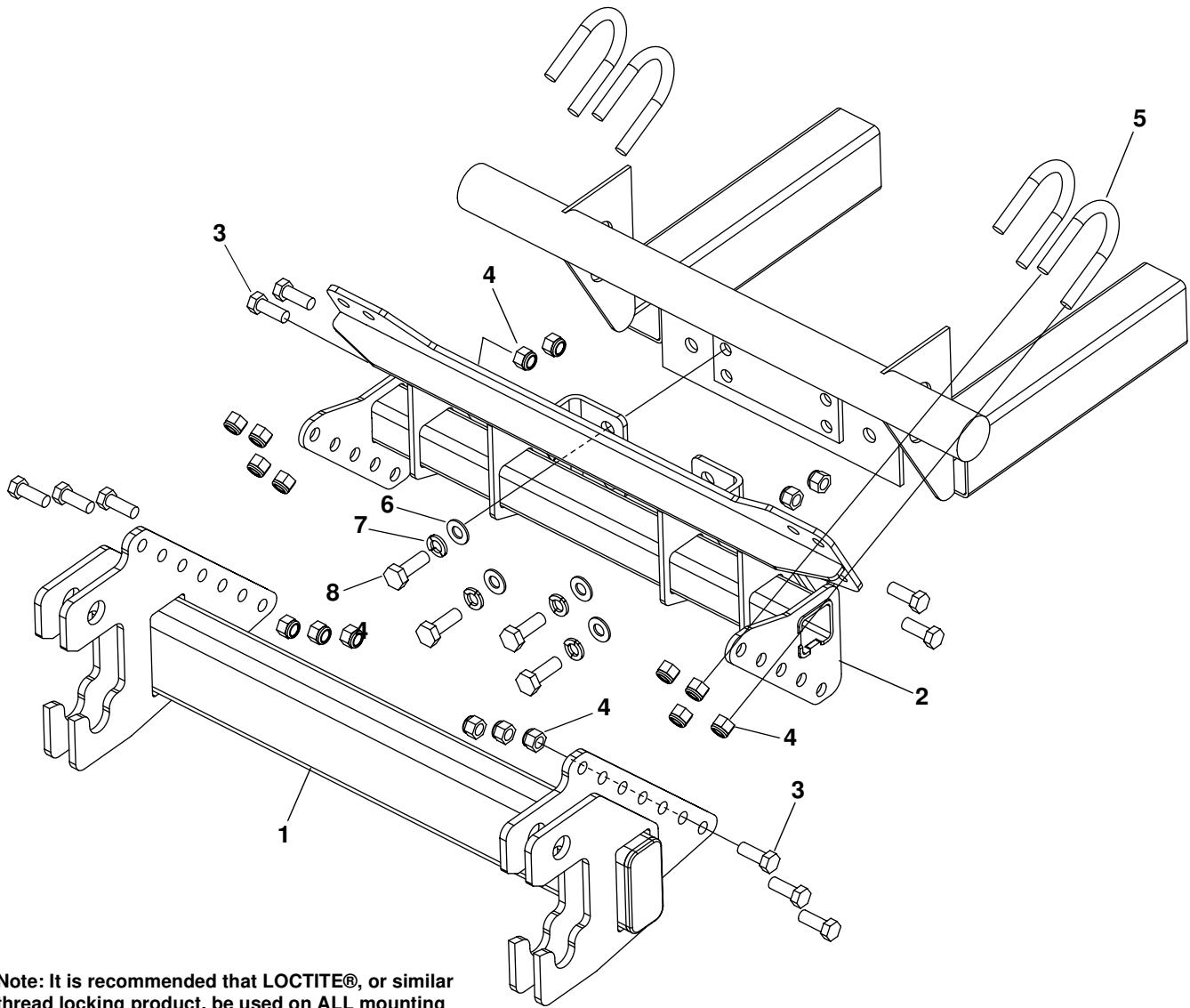

Note: It is recommended that LOCTITE®, or similar thread locking product, be used on ALL mounting hardware (i.e. Nuts, Cap Screws, Bolts, etc.).

ITEM	PART NO.	DESCRIPTION	QTY.
1		UTV Mount.....	1
2		Weldment, Mounting.....	1
3		HHCS, 3/8-16 x 1".....	10
4		LN, 3/8"-16.....	18
5		U-Bolt, 3/8"-16 x 1-3/4" x 2-3/4".....	4
6		PW, 3/8".....	4
7		LW, M10.....	4
8		HHCS, M10-1.25 x 30 mm.....	4
9	96117156	Kit, HDWE (Includes items 3-8) (Not Shown).....	1

SNO-WAY® INTERNATIONAL, INC.

**SNO-WAY**  
SNOW & ICE CONTROL EQUIPMENT

Hartford, WI 53027 USA  
Website: [www.snoway.com](http://www.snoway.com)  
©2018 Sno-Way® International

[www.storksplows.com](http://www.storksplows.com)