

SERIES  
G & H

CHEV K-20, K-30, GMC K-25, K-35  
CHEV V-30, GMC V-35  
CHEV 3/4 TON SUBURBAN

1973-1987  
1988-1989  
1973-1989

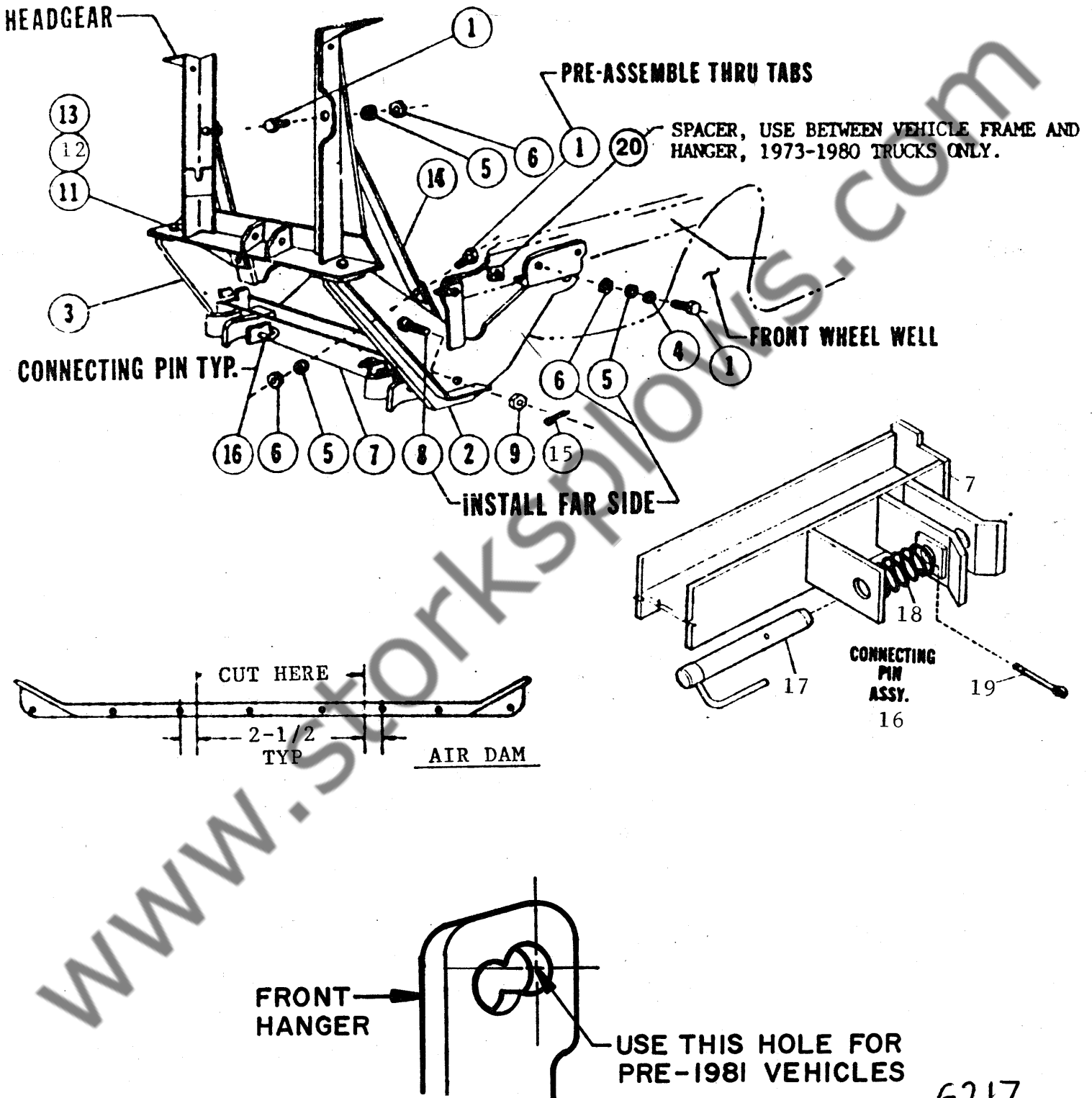

AL246  
REV B



## PARTS LIST

AL246 REV B

REF#	PART#	QTY.	DESCRIPTION * PART OF 6668 BOLT BAG
1	90244	9	* 5/8-11 X 1-1/2 (NC) GR.5 CAPSCREW
2	5366	1	DRIVER SIDE PUSHPLATE
3	5365	1	PASSENGER SIDE PUSHPLATE
4	90323	5	* 5/8 FLATWASHER
5	90366	11	* 5/8" LOCKWASHER
6	90343	11	* 5/8-11 (NC) NUT
7	1513	1	PUSHBEAM (27" OVERALL LENGTH)
8	5005	2	* 5/8-11 X 1-1/2 (NC) DRILLED CAPSCREW
9	90446	2	* 5/8-11 (NC) SLOTTED NUT
10	90247	2	* 5/8 X 2 (NC) GR.5 CAPSCREW
11	90210	2	* 1/2 X 1-1/2 (NC) GR.5 CAPSCREW
12	90364	2	* 1/2" LOCKWASHER
13	90337	2	* 1/2" (NC) NUTS
14	3954	2	HEADGEAR BRACE
15	90012	2	* 3/16 X 1-3/4 COTTER PIN
16	6920	2	CONNECTING PIN ASSEMBLY
17	6815	2	CONNECTING PIN W/HANDLE
18	821	2	* SPRING
19	90601	2	* 1/4 X 1-1/2 COTTER PIN
	4289	2	* 3/4 X 1-7/8 MACHINE PIN
	90658	2	* 5/32 X 1-1/4 COTTER PIN
	3	1	CONNECTING PIN RELEASE
20	6049	2	* SPACER
	A5871	1	DASH BRACKET BAG

FASTENER TORQUE (FT-LB)			
DIAMETER- THREADS PER INCH	GRADE DESIGNATION		
	 GRADE 2	 GRADE 5	 GRADE 8
1/4 - 20	6	9	13
5/16 - 18	11	18	28
3/8 - 16	19	31	46
7/16 - 14	30	50	75
1/2 - 13	45	75	115
9/16 - 12	66	110	165
5/8 - 11	93	150	225
3/4 - 10	150	250	370
7/8 - 9	150	378	591
1 - 8	220	583	893

**A. 1981-1987** - IF VEHICLE IS EQUIPPED WITH AIR DAM EITHER REMOVE IT OR SECTION IT TO CLEAR PUSHPLATES DURING ASSEMBLY. (SEE ILLUSTRATION)

**1973-1987** - LIFT VEHICLE USING FLOOR JACK, UNDER TRANSMISSION CROSSMEMBER. ON DRIVER'S SIDE REMOVE BOLT HOLDING BRAKE LINE CLIP ON INSIDE OF FRAME, BEHIND STEERING BOX. BEND BRAKE LINE DOWN TO CLEAR SLOTTED HOLE IN FRAME. ON THE PASSENGER SIDE REMOVE BOLT HOLDING BRAKE LINE CLIP ABOVE FRONT EDGE OF CROSS-MEMBER THAT RUNS UNDER ENGINE. BEND BRAKE LINES UP TO CLEAR SLOTTED HOLE IN FRAME.

**1981-1987** - REMOVE THE LOWER BUMPER BRACKET BOLTS FROM THE ENDS OF BOTH THE DRIVERS AND PASSENGERS SIDE FRAME RAILS (THESE BOLT THROUGH THE FRAME WEB JUST ABOVE THE LOWER EDGE OF THE BUMPER). RE-DRILL HOLES TO 5/8".

**CAUTION!!!! BEFORE DRILLING ANY HOLES BE SURE THAT THE BACK SIDE OF WHATEVER IS BEING DRILLED IS CLEAR OF ANY OR ALL WIRES, BRAKE LINES, FUEL LINES, ETC.**

**B. 1973-1987** - INSERT 5/8 X 1-1/2 BOLTS (1), POINTING FORWARD, INTO INNER TABS ON PUSHPLATES (2,3) AS BOLTS CANNOT BE INSTALLED AFTER PUSHPLATES ARE ASSEMBLED ON VEHICLE.

**C. 1981-1987** - INSTALL DRIVER SIDE PUSHPLATE (2) TO OUTSIDE OF FRAME, INSIDE OF SPRING, AND OUTSIDE OF STABILIZER BAR. RAISE FRONT END OF PUSHPLATE TO PERMIT INSTALLATION OF 5/8 X 2 BOLT (10) WITH FLATWASHER (4) THROUGH FRONT PUSHPLATE TAB HOLE AND REDRILLED BUMPER BRACKET HOLE IN FRAME. SECURE WITH FLATWASHER (4), LOCKWASHER (5) AND NUT (6). INSTALL 5/8 X 1-1/2 BOLT (1) THROUGH FRONT HOLE OF REAR ANGLE SECTION AND FASTEN WITH FLAT-WASHER (4), LOCKWASHER (5) AND NUT (6). (FLATWASHER, LOCK AND NUT GO ON INSIDE OF FRAME).

**1973-1980** - INSTALL DRIVERS SIDE PUSHPLATE (2) TO OUTSIDE OF FRAME, INSIDE OF SPRING, AND OUTSIDE OF STABILIZER BAR. RAISE FRONT END OF PUSHPLATE TO PERMIT INSTALLATION OF 5/8 X 2 BOLT (10) WITH FLATWASHER (4) 1/4 SPACER (20) THROUGH REAR HOLE IN FRONT HANGER AND FRAME. FASTEN WITH FLATWASHER (4), LOCKWASHER (5) AND NUT (6). INSTALL 5/8 X 1-1/2 BOLT (1) THROUGH FRONT HOLE OF REAR ANGLE SECTION AND FASTEN WITH FLATWASHER (4), LOCKWASHER (5) AND NUT (6) (FLATWASHER, LOCK AND NUT GO ON INSIDE OF FRAME).

**D. 1981-1987** - INSTALL PASSENGER SIDE PUSHPLATE (3) TO OUTSIDE OF FRAME, INSIDE OF SPRING, AND OUTSIDE OF STABILIZER BAR. HANG REAR END OF PUSHPLATE ON TOP OF AXLE RUBBER BUMPER MOUNT. RAISE FRONT END OF PUSHPLATE TO PERMIT INSTALLATION OF 5/8 X 2 BOLT (10) THROUGH FRONT PUSHPLATE TAB HOLE INTO REDRILLED BUMPER BRACKET HOLE AND FASTEN WITH FLATWASHER (4), LOCKWASHER (5) AND NUT (6). INSTALL 5/8 X 1-1/2 BOLT (1) THROUGH MIDDLE HOLE OF REAR PLATE, THROUGH SLOTTED HOLE IN FRAME AND SECURE WITH FLATWASHER (4), LOCKWASHER (5) AND NUT (6).

**1973-1980** - INSTALL PASSENGER'S SIDE PUSHPLATE (3) TO OUTSIDE OF FRAME, INSIDE OF SPRING AND OUTSIDE OF STABILIZER BAR. RAISE FRONT END OF PUSHPLATE TO INSTALL 5/8 X 2 BOLT (10) WITH FLATWASHER (4) THROUGH REAR HOLE IN FRONT HANGER 1/4" SPACER (20) AND FRAME. FASTEN WITH FLATWASHER (4), LOCKWASHER (5) AND NUT (6). INSTALL 5/8 X 1-1/2 BOLT (1) THROUGH MIDDLE HOLE OF REAR PLATE, THROUGH SLOTTED HOLE IN FRAME AND FASTEN WITH FLATWASHER (4), LOCKWASHER (5) AND NUT (6).

**E.** ASSEMBLE CONNECTING PIN (16) TO PUSHBEAM (7). FIRST INSERT SPRINGS (18) BETWEEN TWO INNER EARS ON EACH SIDE OF PUSHBEAM. THEN INSERT CONNECTING PIN (17) THROUGH ALL THREE EARS WITH HANDLE OF PIN TOWARDS THE CENTER OF THE BEAM. LEAVING THE HOLE IN THE PIN BETWEEN THE INNER TWO EARS, PULL BACK ON SPRING AND INSTALL COTTER PIN (19).

**F.** ASSEMBLE PUSHBEAM (7) BETWEEN PUSHPLATES, USING DRILLED 5/8 X 1-1/2 BOLTS (8), INSTALLED FROM INSIDE, AND SLOTTED NUTS (9).

**G.** ASSEMBLE HEADGEAR TO PUSHPLATES USING TWO 1/2 X 1-1/2 CAPSCREWS (11), LOCKWASHERS (12) AND NUTS (13).

**H.** INSTALL HEADGEAR BRACES (14) TO PUSHPLATE TABS, USING PRE-ASSEMBLED 5/8 X 1-1/2 BOLTS (1), LOCKWASHERS (5) AND NUTS (6). ATTACH BRACES TO HEADGEAR USING 5/8 X 1-1/2 BOLTS (1), LOCK-WASHERS (5) AND NUTS (6).

**I.** TIGHTEN PUSHBEAM BOLTS AND NUTS AND SECURE WITH 3/16 X 1-3/4 COTTER PINS (15). TIGHTEN ALL OTHER BOLTS AND NUTS.

**J.** ON THE DRIVERS SIDE PUSHPLATE, DRILL ONE 5/8" HOLE THROUGH FRAME USING REAR HOLE OF REAR ANGLE SECTION AS A GUIDE. INSTALL AND TIGHTEN ONE 5/8 X 1-1/2 BOLT (1), FLATWASHER (4), LOCKWASHER (5) AND NUT (6). ON THE PASSENGER SIDE DRILL TWO 5/8" HOLES THROUGH FRAME USING LOWER REAR HOLE AND FRONT HOLE IN REAR PLATE OF PUSHPLATE AS A GUIDE. INSTALL AND TIGHTEN TWO 5/8 X 1-1/2 BOLTS (1), LOCKWASHERS (5) AND NUTS (6).

**NOTE:** HEADGEAR IS PACKED IN COMMON ATTACHING BOX.