



WESTERN PRODUCTS
7777 NORTH 73RD STREET
P.O. BOX 23045
MILWAUKEE, WISCONSIN 53223

A DIVISION OF DOUGLAS DYNAMICS, INC.

Box No. 60940
Model 1300
Ford Ranger/Explorer 4 x 4
Mazda Navajo 4 x 4
Lift-Mount
October 24, 1990

MINIMUM VEHICLE RECOMMENDATIONS

Aux. Light Kit
Frt. Aux. Air Bag Springs
HD Alternator
HD Battery

REAR BALLAST: When blade is attached - 300-500 lbs. for RANGER, 150 lbs. for EXPLORER or NAVAJO. **WEIGHTS MUST BE SECURED.**

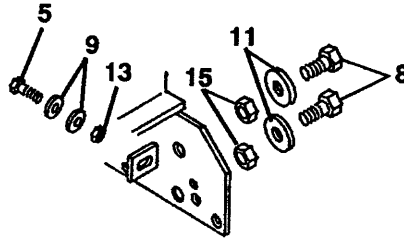

1988 & EARLIER RANGER

PARTS DIAGRAM & LIST

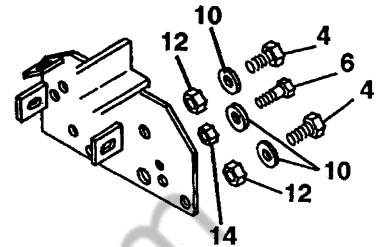

1989 & 1990 RANGER

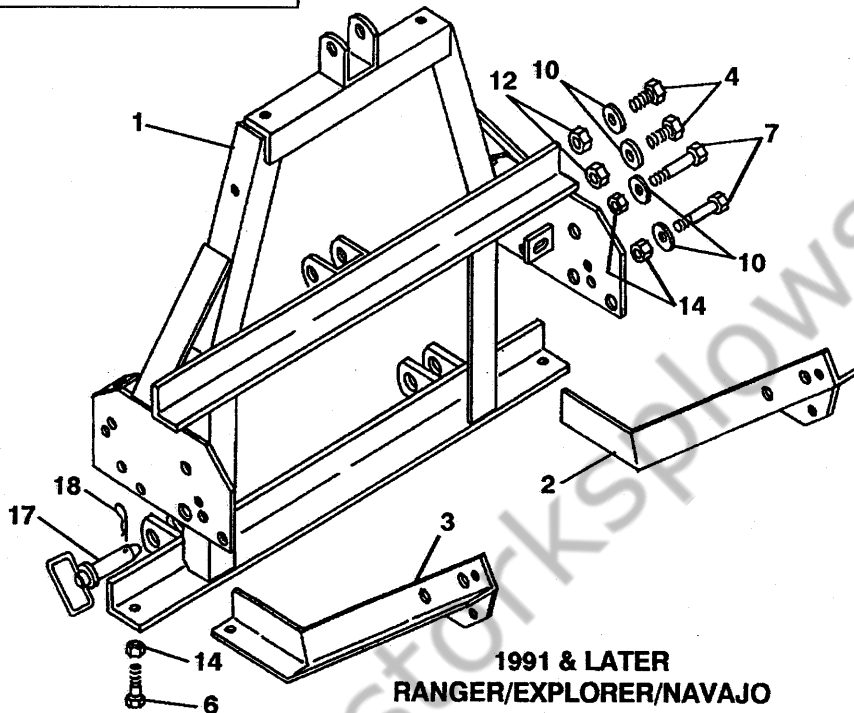

1991 & LATER RANGER/EXPLORER/NAVAJO

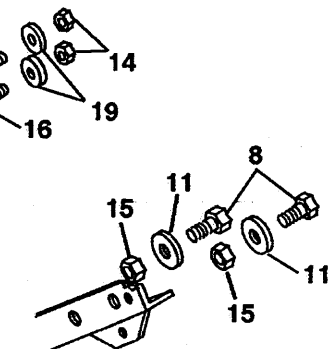

1990 & EARLIER RANGER

ITEM	PART NO.	QUAN.	DESCRIPTION
1	61230	1	LIFT FRAME 1300
2	61231	1	THRUST ARM CU
3	61233	1	THRUST ARM DR
4	95080	4	M14X2X30 HX CS G8.8
5	90067	2	7/16-14X1-1/2 HX CS G5 ZP
6	90100	4	1/2-13X1-1/2 HX CS G5 ZP
7	90106	4	1/2-13X3-1/2 HX CS G5 ZP
8	90127	8	5/8-11X1-1/2 HX CS G5 ZP
9	91104	4	7/16 PLAIN WASHER TY A STD ZP
10	91105	8	1/2 PLAIN WASHER TY A STD ZP
11	91106	8	5/8 PLAIN WASHER TY A STD ZP
12	95185	4	M14X2 PT HX LK NUT NYIS
13	91334	2	7/16-14 PT HX LK NUT NYIS ZP
14	91335	10	1/2-13 PT HX LK NUT NYIS ZP
15	91337	8	5/8-11 PT HX LK NUT NYIS ZP
16	90499	2	1/2-13X1-9/16 U-BOLT SQ BEND ZP
17	93028K	2	HITCH PIN 1" X 3-1/2"
18	91965K	2	HAIRPIN COTTER - 5/32"
19	91160	4	WASHER - SPECIAL

NOTE: Colored fasteners are Metric.

Abbreviations	
BPO	Black Phosphate & Oil
CS	Cap screw
CU	Curb Side
DR	Driver Side
G	Grade
HX	Hex
LK	Lock
M	Metric
NYIS	Nylon Insert
PT	Prevailing Torque
SQ	Square
STD	Standard
TRTS	Thread Rolling Tapping
TY	Type
ZP	Zinc Plated

NOT SHOWN

93164	2	1/4-20X1 HX TRTS TY TT BPO
-------	---	----------------------------

Recommended Fastener Torque Chart (Ft.-Lbs.)			
Size	SAE	SAE	SAE
	Grade 2	Grade 5	Grade 8
1/4-20	8	9	13
5/16-18	11	18	28
3/8-18	19	31	48
3/8-24	24	48	68
7/16-14	30	50	75
1/2-13	45	75	115
9/16-12	66	110	165
5/8-11	93	150	225
3/4-10	150	250	370
7/8-9	202	378	591
1-8	300	583	893

Metric Grade 8.8 (Ft.-Lbs.)			
Size	Torque	Size	Torque
M 8	7	M 12	80
M 8	17	M 14	95
M 10	35	M 16	155

These torque values apply to lift-frame fasteners except those noted in the instruction.

NOTE; DIRECT HYDRA-TURN® HOSES AND FITTINGS AWAY FROM STOPS AND PINCH POINTS

Box No. 60940
 Model 1300
 Ford Ranger/Explorer 4 x 4
 Mazda Navajo 4 x 4
 Lift-Mount

INSTALLATION INSTRUCTIONS

AS VIEWED FROM DRIVER SIDE

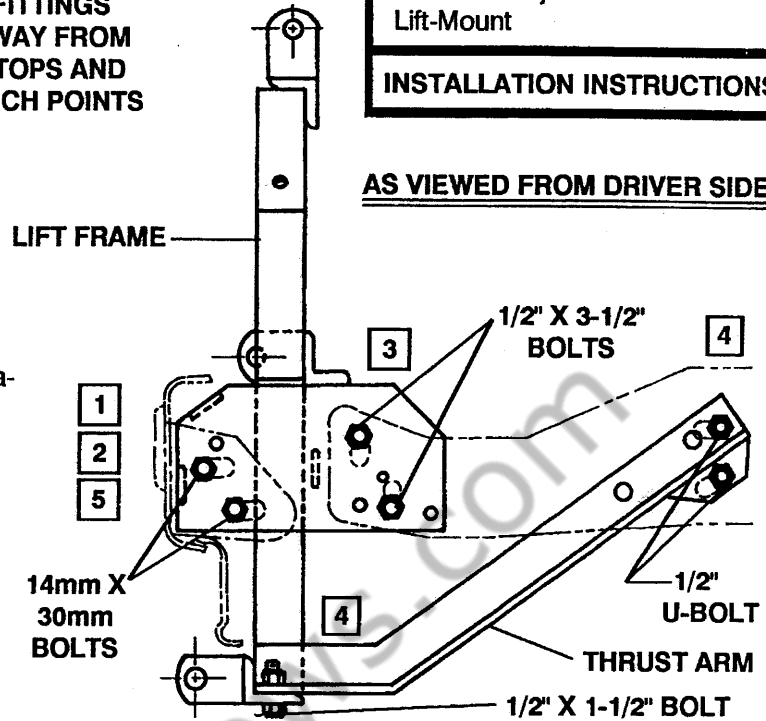

1991 & LATER RANGER/EXPLORER/NAVAJO

IMPORTANT: Read instructions before assembling. Bolts should be finger tight until the installation is completed. Preventive maintenance can prevent accidents. Use standard methods and practices when attaching snowplow including wearing safety glasses during drilling.

1991 & LATER RANGER/EXPLORER/NAVAJO

1. Remove bumper/air deflector, with brackets, from vehicle. Retain fasteners and reinstall whenever Lift Frame is removed from vehicle.
2. Reposition each bracket 1/4" farther out on bumper and secure.
3. Align two holes in lift frame side plate to vehicle frame bumper bracket attaching slots. Fasten with 1/2" x 3-1/2" bolts, flat washers to frame and locknuts.
4. Place short leg of Thrust Arm on top of lift frame bottom cross angle and long leg against vehicle frame. Loop 1/2" U-bolt through vehicle frame slots. NOTE: Be careful not to drop U-bolt into vehicle frame. Attach Thrust Arm to the legs of U-bolt using special washers and locknuts. Secure Thrust Arm to Lift Frame with 1/2" x 1-1/2" bolt and locknut.

TIGHTEN ALL BOLTS TO CORRESPONDING TORQUE CHART VALUES.

5. Align bumper brackets to outboard sides of lift frame side plates and secure using 14mm x 30mm bolts, 1/2" flat washers to slots and locknuts. NAVAJO models may require notching of air deflector when blade is in highest stacking position.

1989 & 1990-RANGER

1. Remove bumper/air deflector, with brackets, from vehicle.
2. Reposition each bracket 1/4" farther out on bumper and secure.
3. Align two holes in lift frame side plate to vehicle frame bumper bracket attaching slots. Fasten with 14mm x 30mm bolts, flat washers to frame and locknuts.
4. Place short leg of Thrust Arm on top of lift frame bottom cross angle and long leg against vehicle frame. Attach Thrust Arm to the slot and hole in vehicle frame with 5/8" x 1-1/2" bolts, flat washers to frame and locknuts. Secure Thrust Arm to Lift Frame with 1/2" x 1-1/2" bolt and locknut.

TIGHTEN ALL BOLTS TO CORRESPONDING TORQUE CHART VALUES.

5. Drill 1/2" hole thru frame at lift frame hole indicated. Secure using 1/2" x 1-1/2" bolt, flat washer to frame and locknut.
6. Align bumper brackets to outboard sides of lift frame side plates and secure with existing fasteners. Using air deflector with snowplow may require cutting of notches for coupling lug clearance.

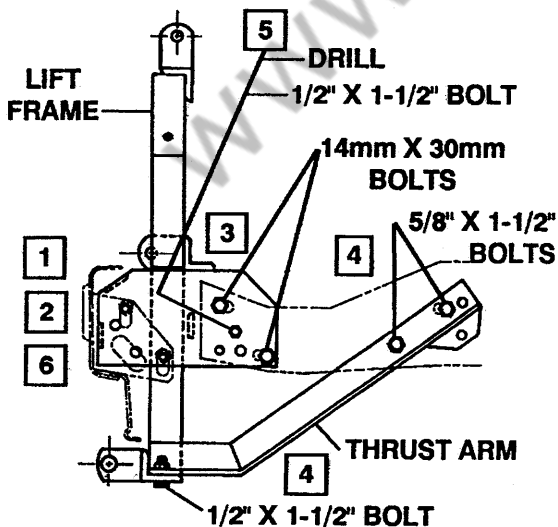

1989 & 1990 RANGER

Continued on Page 3.

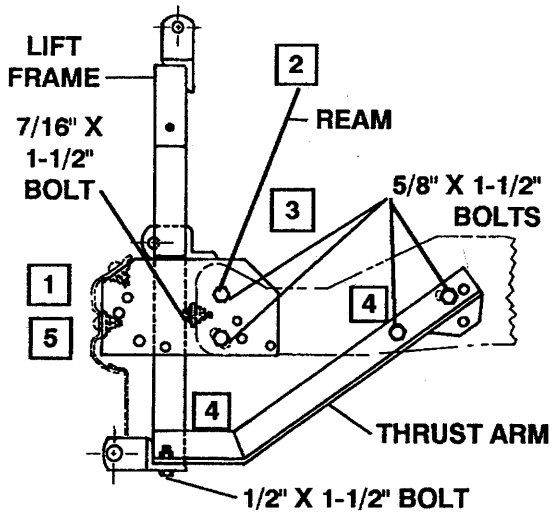

1988 & EARLIER RANGER

1988 & EARLIER - RANGER

1. Remove the bumper/air deflector from the vehicle.
2. Ream hole indicated in lift frame side plate for 5/8" bolt.
3. Align the two large holes in lift frame side plate to slot and hole in the vehicle frame and attach using 5/8" x 1-1/2" bolts, flat washers to frame and locknuts. Secure tab to end of frame using 7/16" x 1-1/2" bolt, flat washers and locknut.
4. Place short leg of Thrust Arm on top of lift frame bottom cross angle and long leg against vehicle frame. Attach Thrust Arm to the slot and hole in vehicle frame with 5/8" x 1-1/2" bolts, flat washers to frame and locknuts. Secure Thrust Arm to Lift Frame with 1/2" x 1-1/2" bolt and locknut.

TIGHTEN ALL BOLTS TO CORRESPONDING TORQUE CHART VALUES.

5. Attach bumper to lift frame tabs using existing fasteners. If air deflector is used with the snowplow, cut notches for coupling lug clearance.

LIGHT KIT ASSEMBLY 1989 & LATER VEHICLES - Use Box No. 60740 Headlamp Kit - 4 Wire and Box No. 60770 Harness/Bracket Kit - HB1 (9004).

LIGHT KIT ASSEMBLY 1988 & EARLIER VEHICLES - Use Box No. 60740 Headlamp Kit - 4 Wire and Box No. 60745 Harness/Bracket Kit - 2B/2D.

NOTE - 1989 & Later Vehicles - The 1/4" x 1" Tapping Screws may be used to mount the hydraulic unit solenoid to existing holes in curb side inner fender sheet.

INSTALLATION INSTRUCTIONS FOR - SOLENOID CONTROL 1989 & 1990 RANGER 1991 & LATER RANGER/EXPLORER/NAVAJO

For 1988 and Earlier
RANGERS with IIA Controls,
See Page 4

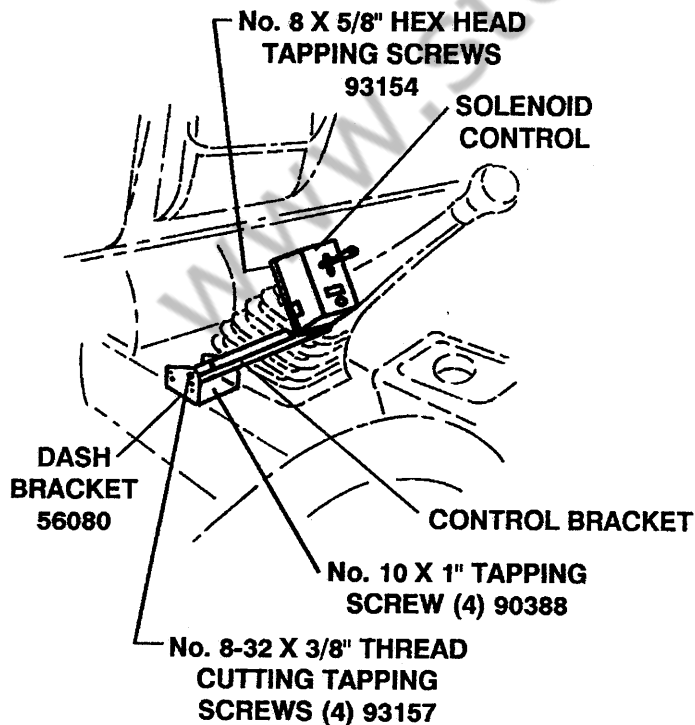

1. Temporarily assemble Solenoid Control to Control Bracket using No. 8 x 5/8" hex head screws, and Control Bracket to Dash Bracket, using No. 8 x 3/8" hex head thread cutting screws.
2. Open ash tray and move drivers seat forward. **MANUAL TRANSMISSIONS:** place shift lever in second gear. Locate control assembly to left of shift lever. **AUTOMATIC TRANSMISSIONS:** place control on top of tunnel in a convenient location. Check for adequate control lever clearance and mark Dash Bracket location.
3. Disassemble Control Bracket from Dash Bracket. **CHECK** under marked location for wires or other interference. Place Dash Bracket in marked location and drill one 1/8" hole using bracket as a template. Loosely attach bracket with a No. 10 x 1" sheet metal screw and lock washer. One at a time, drill remaining holes and secure. **MANUAL TRANSMISSIONS** - drill two additional left side clearance holes in Dash Bracket, for flat surface mounting.
4. Reassemble Control Bracket to Dash Bracket. Bend top flange of Control Bracket to desired position.

INSTALLATION INSTRUCTIONS FOR 59700 BLADE GUIDE ASSEMBLY

Insert pointed end of clamp into coil of Blade Guide Rod. Attach a Blade Guide Rod to each outer rib using 5/16" x 1" capscrews and locknuts as shown in diagram.

PARTS LIST 59700 — BLADE GUIDE ASSEMBLY

Item	Part No.	Quan.	Description
1	59697	2	BLADE GUIDE ROD, S-HOOK & FLAG
2	59694K	1	BLADE GUIDE FLAG
3	59696	1	S-HOOK
4	59691	1	BLADE GUIDE ROD
5	59946	2	CLAMP
6	90020	4	5/16-18X1 HX CS G2 ZP
7	91332	4	5/16-18 PT HX LK NUT NYIS ZP

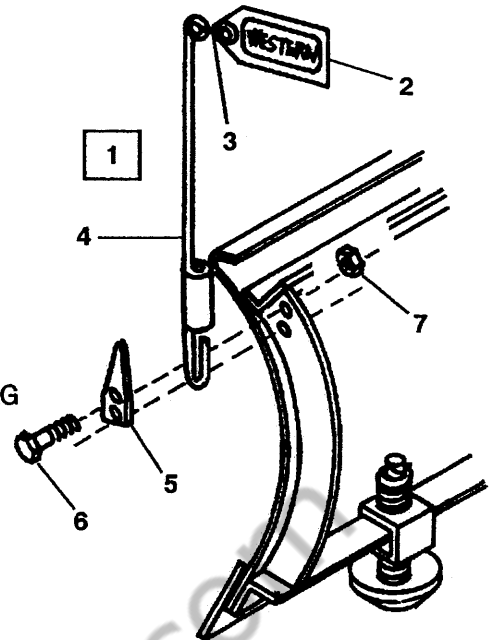

13009-8908

INSTALLATION INSTRUCTIONS FOR — IIIa CONTROL 1988 & EARLIER RANGER

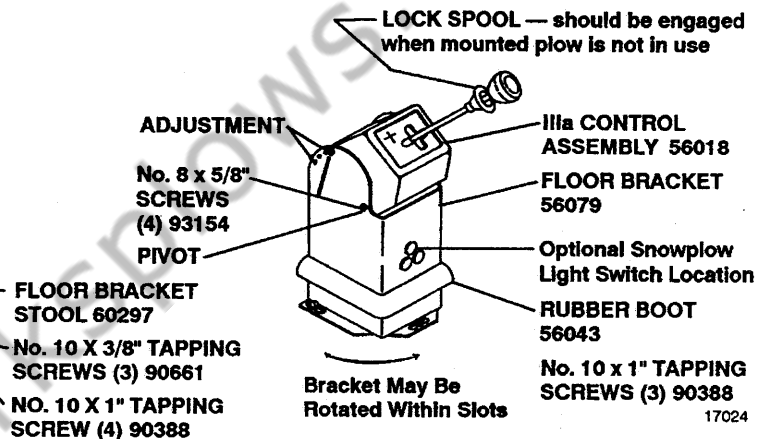
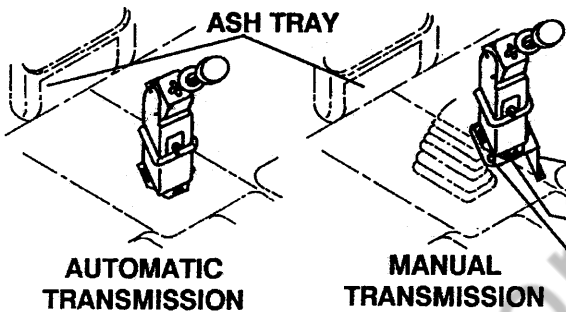

AUTOMATIC TRANSMISSION

1. Remove top knock-out in front of Floor Bracket to receive Light Kit Toggle Switch. Temporarily assemble IIIa Control to Floor Bracket using No. 8 x 5/8" long hex head screws.
2. With ash tray open and seat forward, position assembly on top of passenger side of tunnel in a convenient location for driver. Verify that the control lever will clear vehicle components in all positions. Mark bracket location.
3. Disassemble bracket and place in marked location. CHECK under hole locations for wires or other interference before drilling a 9/64" hole through center of bracket slot. Loosely attach bracket with a No. 10 x 1" sheet metal screw and lock washer. Using bracket as a template, drill through center of each slot one at a time and loosely attach with screws and lock washers. Drilling in center of slots will allow bracket to be rotated to desired position.

MANUAL TRANSMISSION

1. Remove top knock-out in front of Floor Bracket to receive Light Kit Toggle Switch. Temporarily assemble Floor Bracket to Floor Bracket Stool with No. 10 x 3/8" long hex head tapping screws and IIIa Control to Floor Bracket with No. 8 x 5/8" long hex head screws.
2. Place IIIa Control in lower detent, manual transmission in reverse and passenger seat all the way forward. Position assembly with bracket against seat, rear edge of stool tight to bottom of tunnel and assembly angled towards operator (maintain adequate clearance between control lever and shift lever). Mark hole locations and disassemble Floor Bracket assembly.
3. CHECK under hole locations for wires or other interference before drilling 9/64" hole using rear stool flange hole as template. Secure with No. 10 x 1" sheet metal screw and lock washer. Repeat in front flange hole and large hole in top of stool. Loosely attach Floor Bracket to Stool.

ALL VEHICLES

4. Slide Rubber Boot over top of bracket and past switch hole. Attach headlamp harness wires to switch and install switch into bracket.
5. Pass control cables through holes drilled in firewall per hydraulic instructions. Place control in bracket in desired position and secure. Rotate assembly to desired position and tighten mounting screws. Slide Rubber Boot down to cover screws.

The following are registered® and unregistered™ Trade Marks of Douglas Dynamics, Inc.
WESTERN® ISARMATIC® Hydra-Turn® Roll-Action™ PRO-GUARD™

Western reserves the right under its Product Improvement Policy to change construction details and furnish equipment when so altered without reference to illustrations or specifications used herein.