



WESTERN PRODUCTS
7777 NORTH 73RD STREET
P.O. BOX 23045
MILWAUKEE, WISCONSIN 53223

dd A DIVISION OF DOUGLAS DYNAMICS, INC.

Box No. 60777
Model No. 970
Dodge D200-250/300-350
2WD '72 & Later

October 15, 1991

PARTS DIAGRAM & LIST

MINIMUM VEHICLE RECOMMENDATIONS
Aux. Light Kit
HD Alternator
HD Battery
HD Suspension
P235/75 R15 Tires
REAR BALLAST – 500 to 700 lbs when blade is attached. SECURE WEIGHT BEHIND REAR WHEELS.

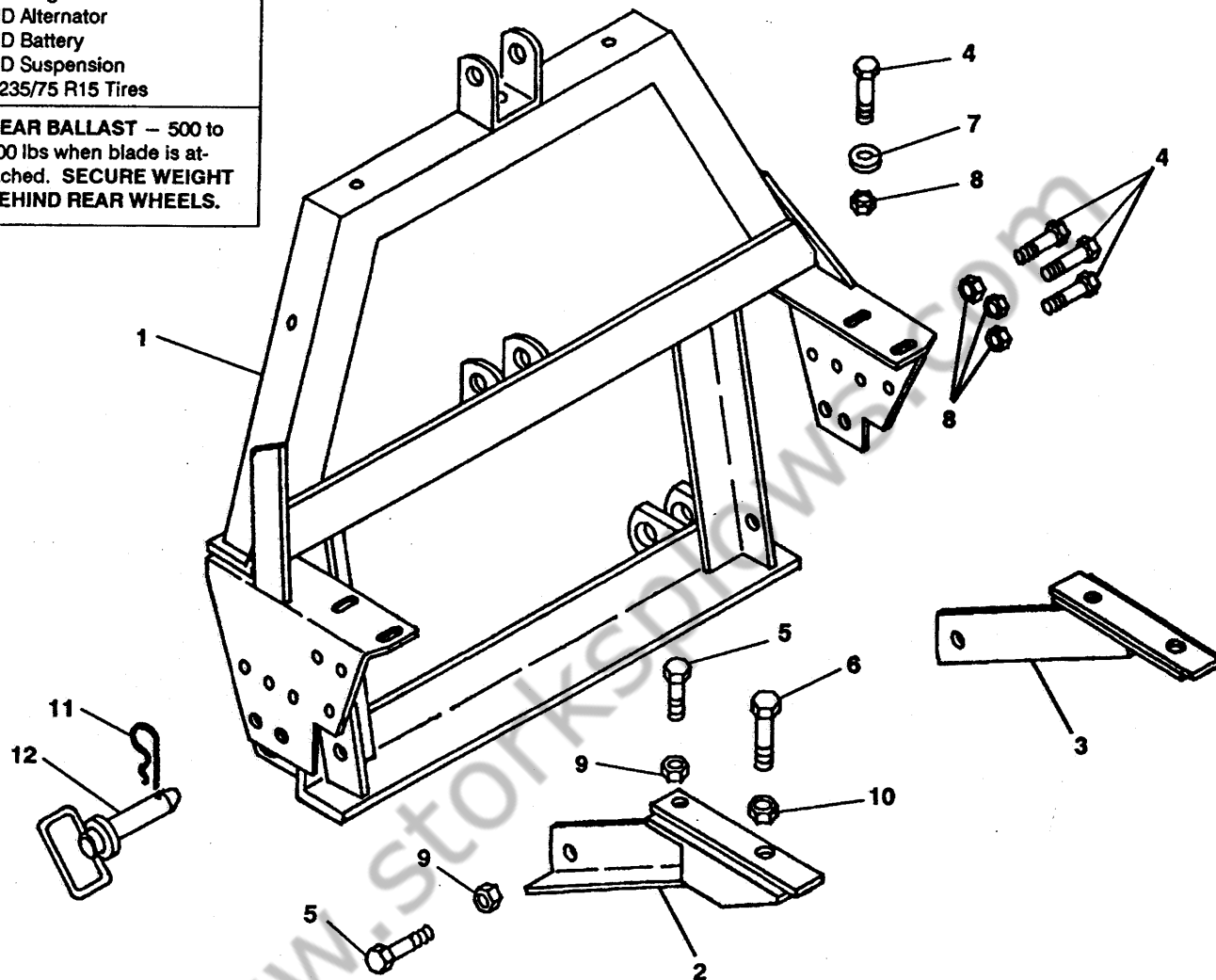

ITEM	PART NO.	QUAN.	DESCRIPTION
1	60781	1	LIFT FRAME - 970
2	60786	1	THRUST ARM DR
3	60787	1	THRUST ARM CU
4	90066	8	7/16-14X1-1/4 HX CS G5 ZP
5	90100	4	1/2-13X1-1/2 HX CS G5 ZP
6	90153	2	3/4-10X1-3/4 HX CS G5 ZP
7	91104	2	7/16 PLAIN WASHER TY A STD ZP
8	91334	8	7/16-14 PT HX LK NUT NYIS ZP
9	91335	4	1/2-13 PT HX LK NUT NYIS ZP
10	91338	2	3/4-10 PT HX LK NUT NYIS ZP
11	91965K	2	HAIRPIN COTTER 5/32"
12	93028K	2	HITCH PIN 1" X 3-1/2"

Abbreviations	
CS	Capscrew
CU	Curb Side
DR	Driver Side
G	Grade
HX	Hex
LK	Lock
NYIS	Nylon Insert
PT	Prevailing Torque
STD	Standard
TY	Type
ZP	Zinc Plated

Recommended Fastener Torque Chart (Ft.-Lbs.)			
Size	SAE	SAE	SAE
	Grade 2	Grade 5	Grade 8
1/4-20	6	9	13
5/16-18	11	18	28
3/8-16	19	31	46
3/8-24	24	46	68
7/16-14	30	50	75
1/2-13	45	75	115
9/16-12	66	110	165
5/8-11	93	150	225
3/4-10	150	250	370
7/8-9	202	378	591
1-8	300	583	893

Metric Grade 8.8 (Ft.-Lbs.)			
Size	Torque	Size	Torque
M 6	7	M 12	60
M 8	17	M 14	95
M 10	35	M 18	155

These torque values apply to lift-frame fasteners except those noted in the instruction.

NOTE; DIRECT HYDRA-TURN® HOSES AND FITTINGS AWAY FROM STOPS AND PINCH POINTS

Box No. 60777
 Model No. 970
 Dodge D200-250/300-350
 2WD '72 & Later

INSTALLATION INSTRUCTIONS

AS VIEWED FROM DRIVER SIDE

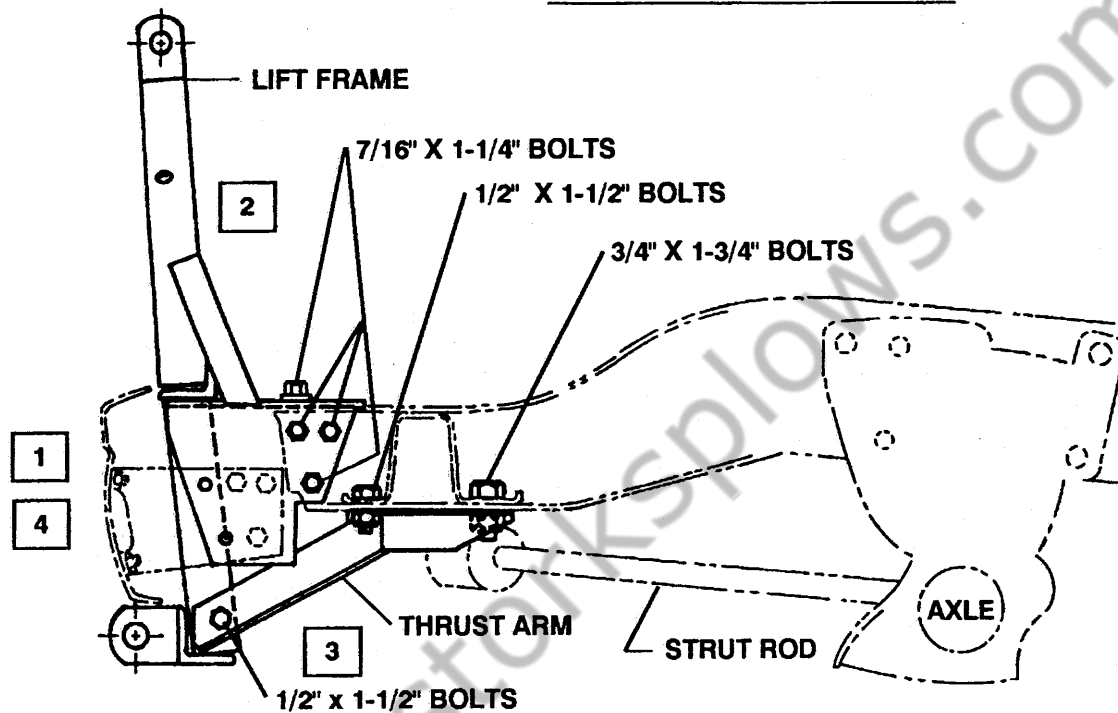

IMPORTANT: Read instructions before assembling. Bolts should be finger tight until the installation is completed. Preventive maintenance can prevent accidents. Use standard methods and practices when attaching snowplow including wearing safety glasses during drilling.

1. Remove bumper from the vehicle, loosen bumper brackets leaving them attached to bumper.
2. Install Lift Frame to frame ends aligning to the three bumper bracket holes and the holes in top flange of vehicle frame. Secure with 7/16" X 1-1/4" bolts, flat washers to slots and locknuts.
3. Attach Thrust Arms to crossmember flanges adjacent to control arm strut rod anchor location and to hanger angle of Lift Frame. Secure with 1/2" X 1-1/2" and 3/4" X 1-3/4" bolts and locknuts.
4. Replace bumper, attaching loosened bumper brackets to outside of Lift Frame side plates. 1991 and later models use rear set of side plate holes, earlier models use front set of holes. Adjust bumper to obtain 1/4" minimum clearance under the hydraulic unit. Secure using existing bumper fasteners and tighten bumper bolts.

TIGHTEN ALL BOLTS TO CORRESPONDING TORQUE CHART VALUES .

NOTE: Assemble and install balance of snowplow per instructions furnished with each respective assembly.

LIGHT KIT ASSEMBLY - FOR DUAL TYPE 2B HEADLAMPS - Use Box No. 60740 Headlamp Kit - 4 Wire and Box No. 61430 Harness Bracket Kit - 2B/2D 5W NF. 4 Wire headlamps do not have blue wires. Blue wire connections per paragraph 5 of 5 Wire instructions are not required for this installation. Install turn signal flasher furnished in Floor Bracket carton in this box. **FOR QUAD TYPE 1A & 2A HEADLAMPS -** Use Box No. 60740 Headlamp Kit - 4 Wire and Box No. 60765 Harness Bracket Kit - 1A & 2A.

**INSTALLATION INSTRUCTIONS
FOR – IIIa CONTROL TO
VEHICLE INSTRUMENT PANEL
DODGE**

ATTENTION: Two brackets for the IIIa Control are furnished with this plow model. With the introduction of a plastic instrument panel on the '81 vehicle, it may be desirable to install the IIIa Control using the Floor Bracket, whenever possible.

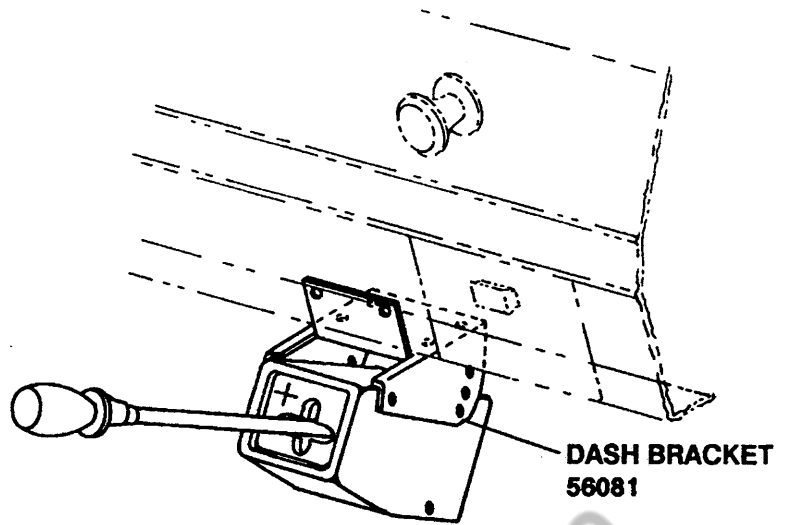

1. Secure Dash Bracket to the IIIa Control using 4-No. 8 x 5/8" long hex head screws.
2. Locate IIIa Control to the left of the ash tray or wherever is most convenient. The lower half of the bracket should fit flat against the bottom flange of the dash. Verify that IIIa Control lever will clear vehicle components in all positions and for adequate drill clearance before drilling holes.
3. Mark and drill two 1/8" holes in the dash to align to the top holes in the bracket.
4. Remove the bracket from the IIIa Control and loosely fasten it to the dash using 2-No. 10 sheet metal screws and lock washers.
5. Mark and drill two holes into the bottom flange of the dash to align to the holes in the bracket. Secure using No. 10 sheet metal screws and lock washers. Tighten all four screws securely.
6. Place IIIa Control into bracket and fasten in desired position.

13475

**INSTALLATION INSTRUCTIONS
FOR – IIIa CONTROL TO
VEHICLE TRANSMISSION TUNNEL**

The IIIa Control should be placed in the vehicle so it is convenient to the operator without interfering with shift levers or the seat when it is fully forward. Use the bracket to drill three 9/64" holes through the floorboard. These holes should be drilled in the center of the Floor Bracket slots, this will permit the bracket to be adjusted at the operators discretion. Fasten using No. 10 x 1" screws and lock washers. Slide the Rubber Boot down to cover the flanges. Align forward holes of bracket and IIIa Control, place No. 8 x 5/8" long slotted hex head screws in these holes. Select best position for the IIIa Control and secure using two more of the same size screws after cable installation is completed.

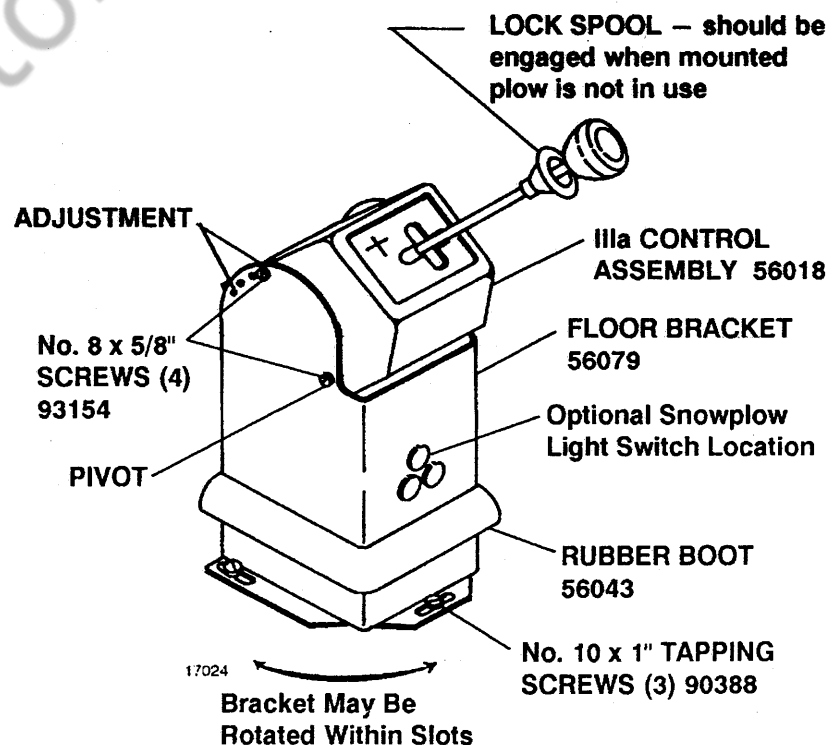

13088-8912

**INSTALLATION INSTRUCTIONS
FOR 59700 BLADE GUIDE ASSEMBLY**

Insert pointed end of clamp into coil of Blade Guide Rod. Attach a Blade Guide Rod to each outer rib using 5/16" x 1" capscrews and locknuts as shown in diagram..

PARTS LIST

59700 – BLADE GUIDE ASSEMBLY

Item	Part No.	Quan.	Description
1	59697	2	BLADE GUIDE ROD, S-HOOK & FLAG
2	59694K	1	BLADE GUIDE FLAG
3	59696	1	S-HOOK
4	59691	1	BLADE GUIDE ROD
5	59946	2	CLAMP
6	90020	4	5/16-18X1 HX CS G2 ZP
7	91332	4	5/16-18 PT HX LK NUT NYIS ZP

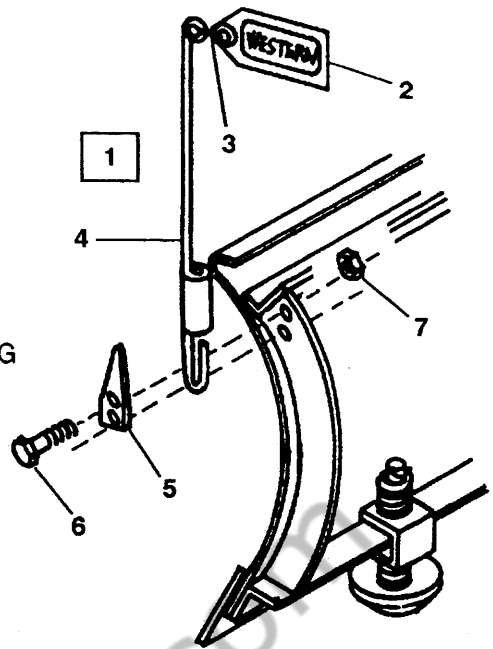

13009-8908

www.storksplows.com

The following are registered® and unregistered™ Trade Marks of Douglas Dynamics, Inc.
WESTERN® ISARMATIC® Hydra-Turn® UniMount® Roll-Action™ PRO-GUARD™

Western reserves the right under its Product Improvement Policy to change construction details and furnish equipment when so altered without reference to illustrations or specifications used herein.