



Fisher Engineering

P.O. Box 529 Rockland, Maine 04841

September 1, 2005
Lit. No. 20607, Rev. 05

**Minute
Mount**
SYSTEM

Attachment Kit

Chevy/GMC

C3500 2 WD w/coil springs

1990 - 00

⚠ CAUTION

See your FISHER® outlet for application recommendations. The Kit Selection Guide has specific vehicle and snowplow requirements.

Table of Contents

Attachment Kit Assembly	2
Bolt Bag Parts List	2
Installation Instructions	3

7148 KIT PARTS LIST

7148 Attachment Kit					
Part #	Qty	Description	Part #	Qty	Description
20604	1	Pushplate – Driver Side	20606	1	Bolt Bag – 7148
20605	1	Pushplate – Passenger Side	7928	2	5/8"-11 x 1-1/2" Gr. 5 Cap Screw
20615	2	Backing Plate			w/Handle

PARTS LIST AND DIAGRAM

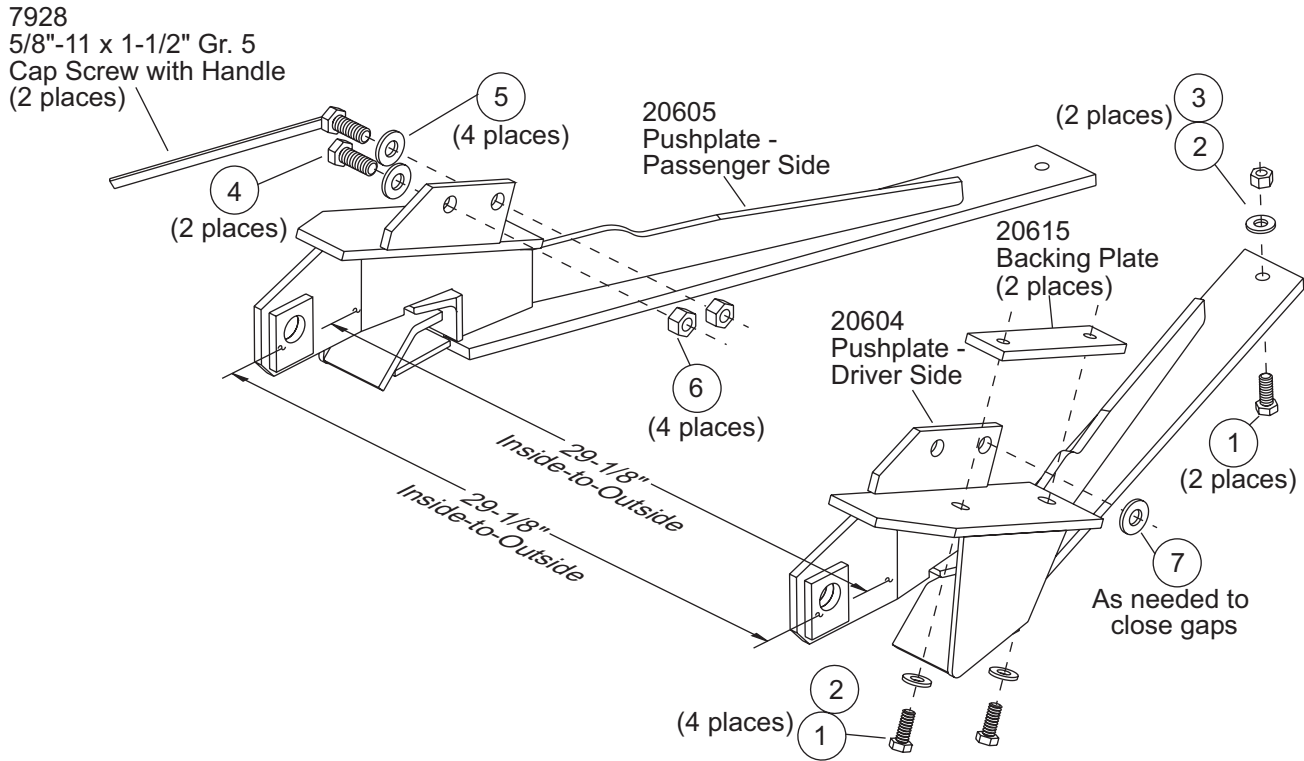

NOTE: Use bottom holes of A-frame when attaching A-frame to lower gear to obtain proper clearance during operation.

Bolt Bag - 20606							
Ref #	Part #	Qty	Description	Ref #	Part #	Qty	Description
1	90210	6	1/2"-13 x 1-1/2" Gr. 5 Cap Screw	5	90576	4	5/8" Gr. 8 Flat Washer
2	90572	6	1/2" Gr. 8 Flat Washer	6	5573	4	5/8"-11 Locknut
3	90355	2	1/2"-13 Locknut	7	90323	6	5/8" Flat Washer
4	90244	2	5/8"-11 x 1-1/2" Gr. 5 Cap Screw				

SAFETY INFORMATION

WARNING



Indicates a potentially hazardous situation that, if not avoided, could result in death or serious personal injury.

CAUTION

Indicates a situation that, if not avoided, could result in minor personal injury and/or damage to product or property.

NOTE: Identifies tips, helpful hints and maintenance information the owner/operator should know.

Torque all fasteners according to the torque chart. For proper fit, do not tighten fasteners until instructed to do so.

NC FASTENER TORQUE (FT-LB)			
DIAMETER- THREADS PER INCH	GRADE		
			
	G2	G5	G8
1/4 - 20	6	9	13
5/16 - 18	11	18	28
3/8 - 16	19	31	46
7/16 - 14	30	50	75
1/2 - 13	45	75	115
9/16 - 12	66	110	165
5/8 - 11	93	150	225
3/4 - 10	150	250	370
7/8 - 9	150	378	591
1 - 8	220	583	893

INSTALLATION INSTRUCTIONS

- Place backing plate through end of frame on driver's side. Align rear slot of driver's side pushplate with slot approximately 5-1/2" from end of frame. (Hole in rear brace and "push pad" should be placed against front axle cross member. Clamp rear brace to cross member.) Fasten using two 1/2" x 1-1/2" cap screws and flat washers.
- Repeat step 1 for passenger's side pushplate.
- Check to see if the inside-to-outside distance between connecting pin arms on pushplates is 29-1/8". Adjust by tapping the back arms of the pushplate. A distance of 29-1/8" between the push arms must be achieved both at the front of the connecting pin and at the back of the connecting pin arm, before the bend line, (see illustration) to ensure they are parallel. Once aligned, fully tighten frame fasteners.
- Using the holes in the rear pushplate braces as guides, drill two 17/32" holes through the axle cross member. Fasten braces with two 1/2 x 1-1/2" cap screws, Gr. 8 flat washers and locknuts. Tighten these fasteners.
- Make sure no vehicle components are inside the frame channel that could be damaged by drilling through front hangers on pushplates. Using these holes as guides, drill four 11/16" holes through inside of frame. With cap screws facing outward from inside of frame, use 5/8" flat washers between frame and pushplate ear, when there is a space between members. Attach the rearmost holes with two 5/8" x 1-1/2" cap screws w/handle, Gr. 8 flat washers and locknuts. Attach remaining washers and locknuts. Attach remaining front holes with two 5/8 x 1-1/2" cap screws, Gr. 8 flat washer and locknuts.
- Make sure all fasteners are fully tightened. Bend bolt handles back toward frame.

NOTE: Before drilling any holes, the proper adjustment of the pushplates **MUST** be achieved.

Copyright © 2000 Douglas Dynamics, L.L.C. All rights reserved. This material may not be reproduced or copied, in whole or in part, in any printed, mechanical, electronic, film or other distribution and storage media, without the written consent of Fisher Engineering. Authorization to photocopy items for internal or personal use by Fisher Engineering outlets is granted.

Fisher Engineering reserves the right under its product improvement policy to change construction or design details and furnish equipment when so altered without reference to illustrations or specifications used herein. Fisher Engineering and the vehicle manufacturer may require and/or recommend optional equipment for snow removal. Fisher Engineering offers a limited warranty for all snowplows and accessories. See separately printed page for this important information. The following are registered (®) trademarks of Douglas Dynamics, L.L.C.: FISHER®, Minute Mount®

Printed in USA