

**8436, 8437-1, 8438, 8439,
8442, 8443, 27480-1, 27780,
27890, 28028, & 28400**

**HARNESS KIT
4-PORT ISOLATION MODULE
LIGHT SYSTEM**

w/3-PLUG SYSTEM HARNESSES

Installation Instructions

⚠ CAUTION

Read this document before installing the snowplow.

⚠ CAUTION

See your sales outlet/Web site for specific vehicle application recommendations before installation. The Kit Selection Guide/Selection List has specific vehicle and snowplow requirements.

8436, 8437-1, 8438, 8439, 8442, 8443, 27480-1, 27780, 27890, 28028, 28400

SAFETY DEFINITIONS

⚠ WARNING

Indicates a potentially hazardous situation that, if not avoided, could result in death or serious personal injury.

⚠ CAUTION

Indicates a potentially hazardous situation that, if not avoided, may result in minor or moderate injury. It may also be used to alert against unsafe practices.

NOTE: Indicates a situation or action that can lead to damage to your snowplow and vehicle or other property. Other useful information can also be described.

FUSES

The snowplow electrical and hydraulic systems contain several automotive blade-style fuses. If a problem should occur and fuse replacement is necessary, the replacement fuse must be of the same type and amperage rating as the original. Installing a fuse with a higher rating can damage the system and could start a fire. Fuse replacement, including fuse ratings and locations, is located in the Maintenance section of the Owner's Manual.

BATTERY SAFETY

⚠ CAUTION

Batteries normally produce explosive gases which can cause personal injury. Therefore, do not allow flames, sparks or lit tobacco to come near the battery. When charging or working near a battery, always cover your face and protect your eyes, and also provide ventilation.



Batteries contain sulfuric acid which burns skin, eyes and clothing.

Disconnect the battery before removing or replacing any electrical components.

TORQUE CHART

⚠ CAUTION

Read instructions before assembling. Fasteners should be finger tight until instructed to tighten according to the torque chart. Use standard methods and practices when attaching snowplow, including proper personal protective safety equipment.

Recommended Fastener Torque Chart (Ft.-Lb.)			
Size	 SAE Grade 2	 SAE Grade 5	 SAE Grade 8
1/4-20	6	9	13
5/16-18	11	18	28
3/8-16	19	31	46
3/8-24	24	46	68
7/16-14	30	50	75
1/2-13	45	75	115
9/16-12	66	110	165
5/8-11	93	150	225
3/4-10	150	250	370
7/8-9	150	378	591
1-8	220	583	893

Metric Grade 8.8 (Ft.-Lb.)			
Size	Torque	Size	Torque
M 6	7	M 12	60
M 8	17	M 14	95
M 10	35	M 16	155

These torque values apply to fasteners except those noted in the instruction.

8436, 8437-1, 8438, 8439, 8442, 8443, 27480-1, 27780, 27890, 28028, 28400

TYPICAL SYSTEM DIAGRAM

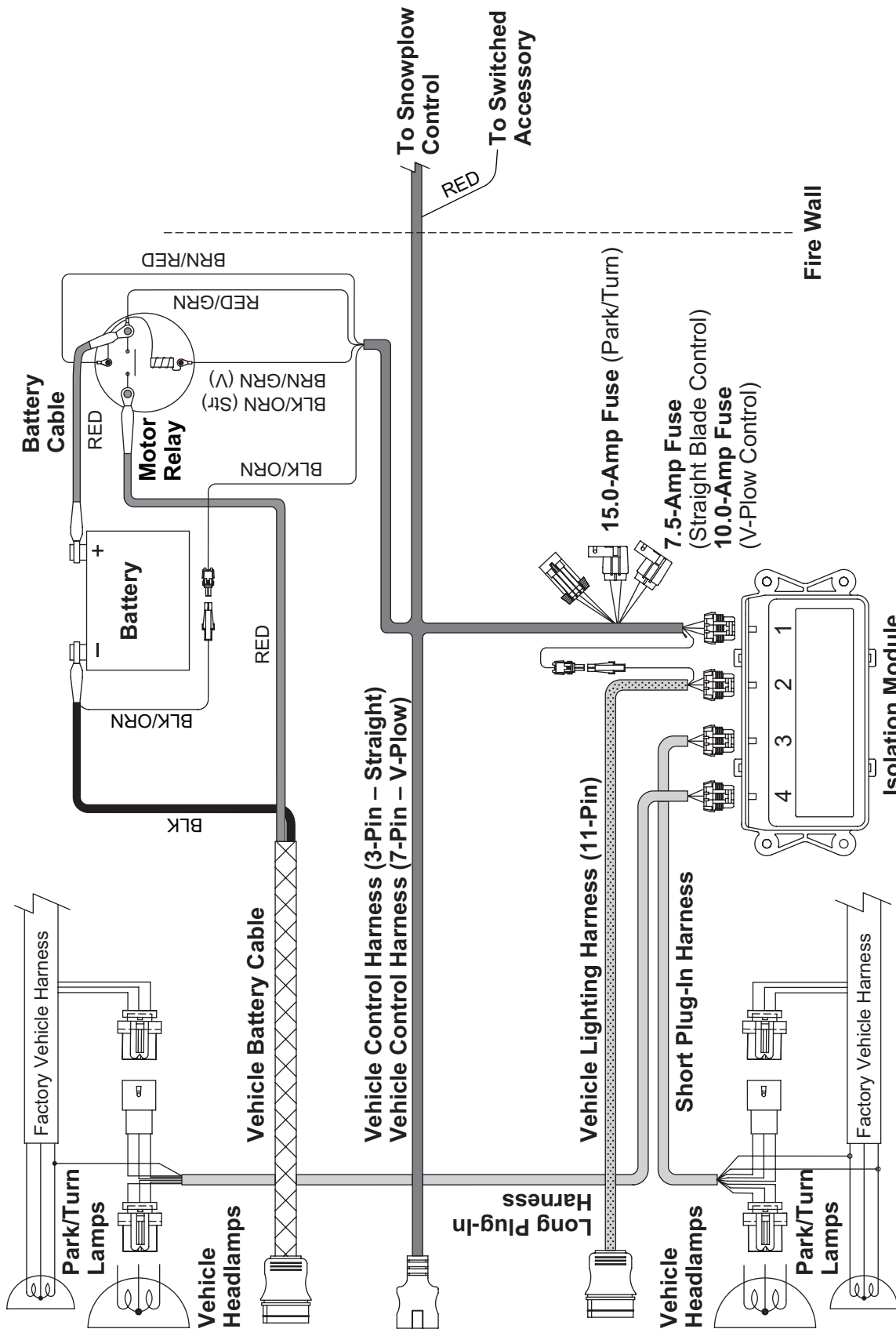

8436, 8437-1, 8438, 8439, 8442, 8443, 27480-1, 27780, 27890, 28028, 28400

MOTOR RELAY AND VEHICLE BATTERY CABLE INSTALLATION

⚠ CAUTION

Batteries normally produce explosive gases which can cause personal injury. Therefore, do not allow flames, sparks or lit tobacco to come near the battery. When charging or working near a battery, always cover your face and protect your eyes, and also provide ventilation.

Batteries contain sulfuric acid which burns skin, eyes and clothing.

Disconnect the battery before removing or replacing any electrical components.

NOTE: When instructed, make all snowplow battery cable connections to the auxiliary battery, if vehicle is so equipped.

NOTE: For vehicles equipped with a tilt cab or tilt hood, a service loop will be necessary when making harness or cable transitions from the cab/hood to the frame. Check the cable installation for interference by raising and lowering the cab/hood a number of times. Add anti-chafing material (installer-supplied) as needed.

1. Turn off the vehicle ignition.
2. Disconnect both the NEGATIVE (-) and the POSITIVE (+) battery cables.
3. Choose a location on the vehicle where the motor relay will be protected from road splash and debris. Motor relay must be within 18" of the vehicle battery. (The motor relay can be farther from the battery if the battery cable provided with either the plug-in harness or adapter kit is longer than 22".)

NOTE: Position motor relay terminals up, horizontal or in between.

⚠ CAUTION

Before installing self-drilling screws or drilling mounting holes, check the selected mounting area for any wires, hoses, or other obstructions.

4. Drill two 9/32" mounting holes using the motor relay mounting plate as a template. Mount the motor relay using 1/4" x 3/4" cap screws, washers, and locknuts.
5. Route the supplied vehicle battery cable from the grille or bumper to the location chosen for mounting the motor relay, avoiding any sharp edges and hot or moving parts. Cable tie only the end section closest to the grille. Lengthening the vehicle battery cable may be necessary on vehicles with batteries located under or behind the cab. If lengthening cables is necessary, use the same gauge wire as the vehicle battery cable, and cover all connections with dual-wall heatshrink tubing to prevent shorting.

⚠ CAUTION

Overtightening terminal attaching nuts may cause seal failure, resulting in premature failure of motor relay.

6. Attach the red wire from the vehicle battery cable to one of the large terminals on the motor relay. Secure with a lock washer and 5/16" nut, and tighten to a maximum of 35 in-lb.

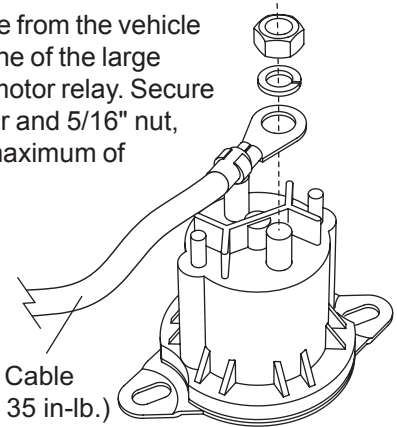

Red Vehicle Battery Cable
(Tighten nut to max. 35 in-lb.)

NOTE: Use dielectric grease on all electrical connections to prevent corrosion. Fill receptacles and lightly coat ring terminals and blades before assembly.

7. Route the black wire from the vehicle battery cable to the NEGATIVE (-) battery terminal. Do not connect at this time. On vehicles with the batteries located under or behind the cab, connect the black wire from the vehicle battery cable to the frame using an existing hole or ground bolt. Prior to attaching, clean away any paint or dirt to ensure a good ground connection. The black/orange wire from the vehicle battery cable will connect to the mating connector on the vehicle control harness.

8436, 8437-1, 8438, 8439, 8442, 8443, 27480-1, 27780, 27890, 28028, 28400

PLUG COVER INSTALLATION

1. Stretch the rectangular opening of the plug cover strap over the end of the molded plug. Place the plug cover over the molded plug when snowplow is not in use.

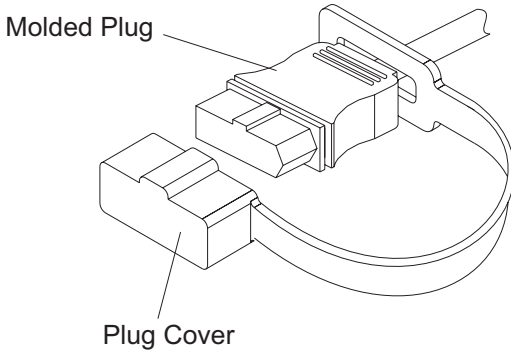

2. If grille plates were not provided, secure the vehicle battery cable so it is protected when not in use and is easily retrieved for connection to the snowplow.
3. If grille plates were provided or you choose to use them, pick the one most suitable for your installation. Slide the plug into the plate.

NOTE: When choosing a location for the grille plate, keep in mind the connection between the vehicle and the snowplow. Mounting the grille plate too close to the center of the vehicle may make it difficult to make your electrical connection to the snowplow.

ISOLATION MODULE MOUNTING

The design of the Isolation Module allows it to be mounted to a variety of surfaces within the engine compartment. The function of the Isolation Module will not be affected by its mounting orientation.

⚠ CAUTION

Before installing self-drilling screws or drilling mounting holes, check the selected mounting area for any wires, hoses, or other obstructions.

Locate a flat surface within the engine compartment of the vehicle for mounting the Isolation Module. For example, the fire wall, fender well or radiator shroud are possible mounting locations. If a flat surface cannot be located, cable tie the Isolation Module to existing brackets or harnessing. Reclosable fastener strips, cable ties, and self-drilling screws are supplied for mounting the Isolation Module. When using the reclosable fastener strips, the mounting surface must be free of dirt and grease. If using self-drilling screws, install the screws in opposite corners if possible.

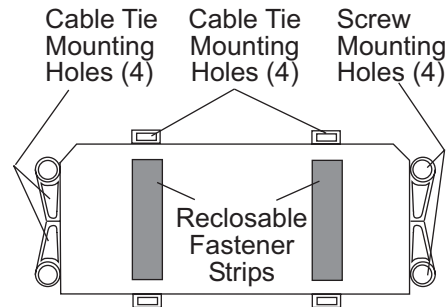

Isolation Module
Bottom View

8436, 8437-1, 8438, 8439, 8442, 8443, 27480-1, 27780, 27890, 28028, 28400

VEHICLE LIGHTING AND VEHICLE CONTROL HARNESS INSTALLATION

Vehicle lighting and vehicle control harnesses are designed to plug into one another when the snowplow is not attached. Plug the harnesses together before cable tying them to ensure adequate length.

NOTE: For vehicles equipped with a tilt cab or tilt hood, a service loop will be necessary when making harness or cable transitions from the cab/hood to the frame. Check the cable installation for interference by raising and lowering the cab/hood a number of times. Add anti-chafing material (installer-supplied) as needed.

1. Route both harnesses around or through the radiator bulkhead to the Isolation Module.
2. Make the following connections:
 - Vehicle control harness to Port 1 on Isolation Module.*
 - Vehicle lighting harness to Port 2 on Isolation Module.*
 - Single-wire connector (black/orange wire) from vehicle control harness to single-wire connector (black/orange wire) on vehicle lighting harness.
 - **For the 8437-1 or 27780 Harness Kit:** Connect supplied dust cover to vehicle control harness 3-position plug near Isolation Module.
 - **For all other harness kits:** Connect configuration plug to vehicle control harness 3-position plug near Isolation Module. (Refer to plug configuration drawing for instructions.)

NOTE: If unsure of headlamp common, configure plug for a **NEGATIVE (-)** common. Complete the installation and check headlamp functions. Turn on the vehicle lights in the low beam mode. Both low beams should be on. If the left low beam does not illuminate, change plug configuration to **POSITIVE (+)** common and test headlamp functions.

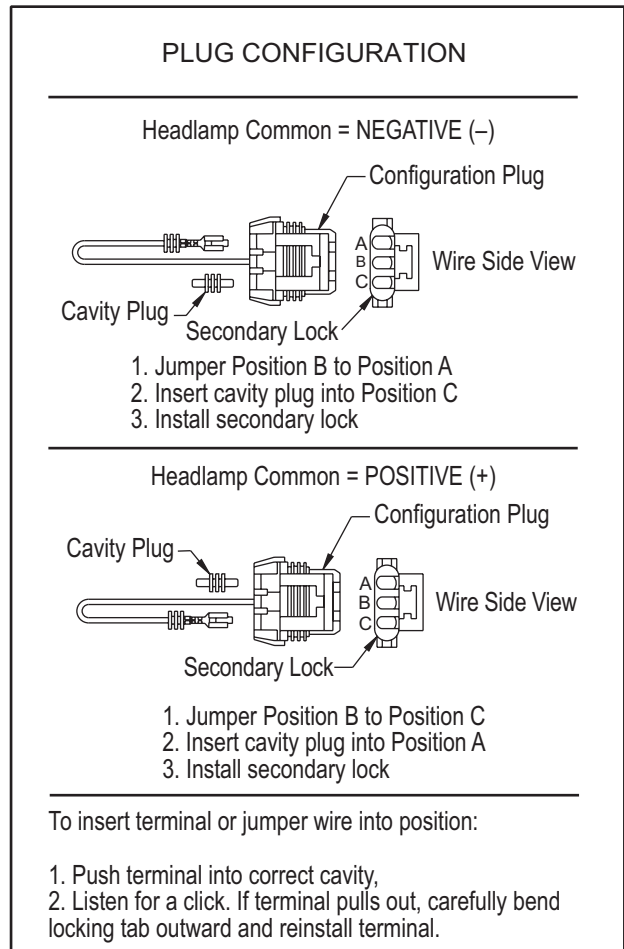

8436, 8437-1, 8438, 8439, 8442, 8443, 27480-1, 27780, 27890, 28028, 28400

- Route the end of the vehicle control harness with the white, 6-pin connector or the 10 loose terminals to the fire wall. Route the vehicle control harness breakout with four wires to the motor relay.

⚠ CAUTION
Overtightening terminal attaching nuts may cause seal failure, resulting in premature failure of motor relay.

Motor relay small terminal connections:

Straight blades: brown/red and black/orange
 V-plows: brown/red and brown/green

Secure wires to small terminals of motor relay with #10 lock washers and 10-32 nuts, and tighten to 15 in-lb.

- Connect the single-wire connector (black/orange wire) from the vehicle control harness breakout to the single-wire connector (black/orange wire) from the vehicle battery cable. Do not cable tie the harness at this time.
- Attach the supplied red battery cable and the red/green wire from the vehicle control harness to a large terminal on the motor relay with a lock washer and 5/16" nut, and tighten to a maximum 35 in-lb. Route the supplied red battery cable between motor relay terminal and POSITIVE (+) battery terminal, avoiding sharp edges and hot or moving parts. Do not make battery connection at this time.

⚠ CAUTION
Before installing self-drilling screws or drilling mounting holes, check the selected mounting area for any wires, hoses, or other obstructions.

- On the driver side, locate an existing hole through the fire wall for the vehicle control harness. If access through the fire wall does not exist, drill a 5/8" hole through the fire wall of the vehicle in a convenient location away from sharp edges, and hot or moving parts.

- Remove the packing material from the end of the vehicle control harness if present. Carefully push the end of the harness through fire wall hole into the cab. Use a grommet, existing plug cover, or proper chafing material to protect the harness where it passes through the fire wall. Route the harness to the selected control mounting location. If the harness has 10 socket-type terminals, follow the instructions in the next section to attach the terminals to the connector. To mount the control, follow the instructions supplied with the control.
- Locate an accessory wire controlled by the ignition switch. Acceptable accessory wires show +12V when the ignition switch is on, and 0V when it is off.
- Route the red wire from the vehicle control harness to this location and trim away excess length.
- Following the recommended splicing procedure, splice the red wire into the switched accessory wire using the supplied parallel splices and heatshrink tubing.

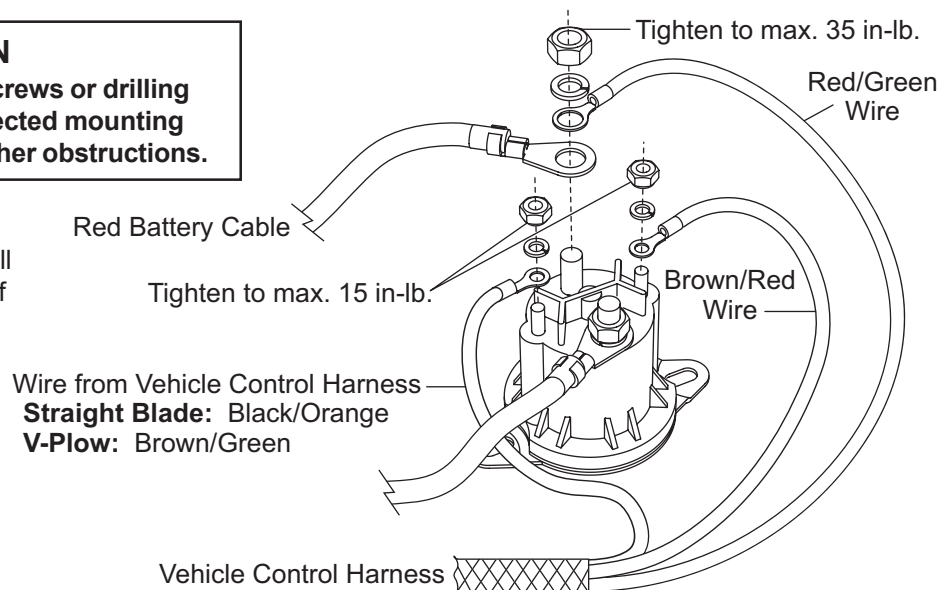

8436, 8437-1, 8438, 8439, 8442, 8443, 27480-1, 27780, 27890, 28028, 28400

**PLUG-IN HARNESS INSTALLATION:
COLORADO/CANYON**

With Headlamp DRLs

Follow instructions for all other applications starting on Page 10.

With Turn Signal DRLs

For vehicles where snowplow daytime running lights (DRL's) are required: 8437-1 Plug-In Harness Kit and 28555 Adapter Kit will be necessary. Follow the installation instructions provided with kits.

For vehicles where snowplow daytime running lights (DRL's) are not required: 27480-1 Plug-In Harness Kit will be necessary. The pink wire from the short plug-in harness will not be used; cut and discard the pink wire.

The 8437-1 Plug-In Harness and 28555 Adapter Kits and Instructions can also be used for DRL-equipped vehicles in the United States if snowplow DRL's are desired.

Prior to installing the plug-in harnesses, you will need to do the following: Open the convoluted tubing approximately 6" from the 10-position connector. Locate the purple turn signal wires and carefully pull each wire out of the harness tubing toward the 10-position connector.

1. Remove the headlamp connectors. Connect the plug-in harnesses to the mating connectors removed from the headlamps. Connect the plug-in harnesses to the mating connections at the headlamps. Route the plug-in harnesses to the Isolation Module. Connect the **driver-side** plug-in harness to Port 3 on the Isolation Module. Connect **passenger-side** plug-in harness to Port 4 on the Isolation Module.

NOTE: Only the short plug-in harness connects to the vehicle parking light circuit.

2. Splice the brown wire from the short plug-in harness into the parking light wire at the vehicle headlamp following the splicing procedure.

3. On the **driver side**, locate the vehicle 16-position rear lighting connector located at the lower rear corner of the battery tray (see photo). Removal of the battery cover may be necessary.



4. Release the light gray connector lock, and separate the connector halves. The rear half of connector is held in place by a push-in plastic fender anchor; removal of this anchor will be required. With the connector free, open the convoluted tubing, and locate the yellow and dark green wires.

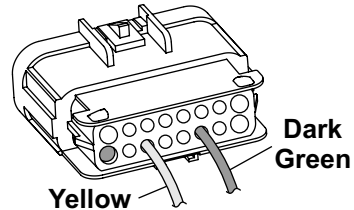

5. Splice the purple wire from the **driver-side** plug-in harness into the yellow wire following the splicing procedure and trimming the purple wire as needed.
6. Splice the purple wire from the **passenger-side** plug-in harness into the dark green wire following the splicing procedure and trimming the purple wire as needed.
7. Connect the two 16-position connector halves and reset the light gray connector lock. Reinstall the push-in plastic fender anchor.
8. Cable tie the vehicle control harness, vehicle lighting harness, and both plug-in harnesses away from any sharp, hot or moving parts. The vehicle control harness and vehicle lighting harness are designed to plug into one another for storage.

**PLUG-IN HARNESS INSTALLATION:
VEHICLES USING THE 27890 HARNESS
KIT**

1. Locate the passenger-side OEM vehicle headlamp connector located near the tilt-hood hinge below the headlamp housing.
2. Remove the small, light gray connector lock by carefully sliding it back away from the connector. Separate the connectors by pushing down on the locking tab and pulling them apart.
3. Connect the short plug-in harness female connector to the male OEM vehicle headlamp connector. Reinstall the small, light gray connector lock.
4. Connect the short plug-in harness male connector to the female OEM vehicle headlamp connector.
5. Repeat Steps 1–4 on the driver side of the vehicle using the long plug-in harness.
6. Route the plug-in harnesses to the 4-port Isolation Module by running the harnesses along the existing cables underneath the engine and radiator area. Connect **driver-side** plug-in harness to Port 3 on the Isolation Module. Connect **passenger-side** plug-in harness to Port 4 on the Isolation Module.
7. Cable tie the vehicle control harness, vehicle lighting harness and both plug-in harnesses away from any sharp, hot or moving parts. The vehicle control harness and vehicle lighting harness are designed to plug into one another for storage.

**PLUG-IN HARNESS INSTALLATION:
VEHICLES USING THE 8443 HARNESS
KIT**

1. Locate the passenger-side OEM vehicle headlamp connector located near the tilt-hood hinge below the headlamp housing.
2. Remove the small, light gray connector lock by depressing the tabs on both sides and pulling outward. Save the connector lock.
3. Disconnect the connector by lifting up on the locking tab and pulling it apart. Carefully unclip the vehicle headlamp harness and reroute it back to the frame, cable tying as necessary.
4. Connect the plug-in harness female connector to the male OEM vehicle headlamp connector. Reinstall the small, light gray connector lock. Route the plug-in harness back toward the frame using existing cable clips.
5. Connect the plug-in harness male connector to the female OEM vehicle headlamp connector.
6. Route the plug-in harness to the 4-port Isolation Module. Connect the plug-in harness to the module by matching harness connector 3 with Port 3 on the Isolation Module and harness connector 4 with Port 4 on the Isolation Module.
7. Cable tie the vehicle control harness, vehicle lighting harness and plug-in harness away from any sharp, hot or moving parts. The vehicle control harness and vehicle lighting harness are designed to plug into one another for storage.

8436, 8437-1, 8438, 8439, 8442, 8443, 27480-1, 27780, 27890, 28028, 28400

**PLUG-IN HARNESS INSTALLATION:
ALL OTHER APPLICATIONS**

NOTE: For vehicles equipped with a tilt cab or tilt hood, a service loop will be necessary when making harness or cable transitions from the cab/hood to the frame. Check the cable installation for interference by raising and lowering the cab/hood a number of times. Add anti-chafing material (installer-supplied) as needed.

1. **For vehicles using the 8436 Harness Kit with the 26641 or 28860 Adapter Kit:** Refer to the illustration below, and configure both plug-in harnesses for HB-5.

For vehicles using the 28028 Harness Kit: The plug-in harnesses connect to the headlamp housings, not the headlamp bulbs.

Install wires in both connectors as shown.
Install supplied secondary connectory locks.

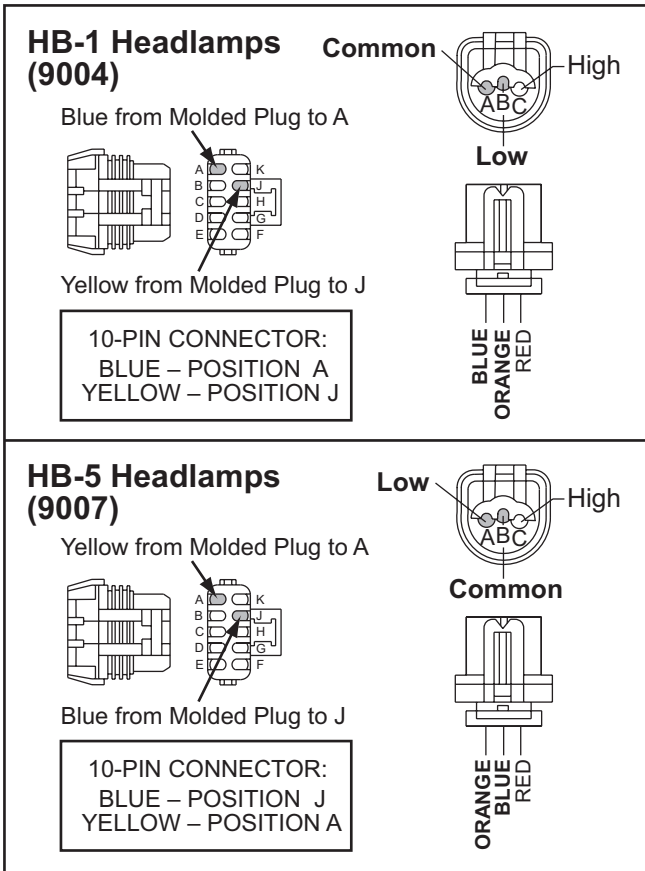

For all other vehicles using the 8436 Harness Kit: Refer to the previous illustration, and configure both plug-in harnesses according to the vehicle's headlamp type.

2. Remove the headlamp or headlamp housing connectors. Connect the plug-in harnesses to the mating connectors removed from the headlamps or headlamp housings.* Connect the plug-in harnesses to the mating connections at the headlamps or headlamp housings. Route harnesses to the Isolation Module. Connect **driver-side** plug-in harness to Port 3 on the Isolation Module. Connect **passenger-side** plug-in harness to Port 4 on the Isolation Module.

NOTE: Only the short plug-in harness connects to the vehicle parking light and DRL circuits.

For vehicles with dedicated DRL bulbs: Splice the pink wire from the short plug-in harness into the DRL POSITIVE (+) wire following the splicing procedure.

For vehicles with headlamp DRLs: The pink wire from the short plug-in harness, if present, is not needed. Cut and discard the pink wire.

3. If not already done during adapter installation, locate the turn signal wire on each side of the vehicle. Splice the purple wire from each plug-in harness into the signal wire on the corresponding side following the recommended splicing procedure.
4. If not already done during adapter installation, splice the brown wire from the short plug-in harness into the parking light wire following the splicing procedure.
5. Cable tie the vehicle control harness, vehicle lighting harness, and both plug-in harnesses away from any sharp, hot or moving parts. The vehicle control harness and vehicle lighting harness are designed to plug into one another for storage.

8436, 8437-1, 8438, 8439, 8442, 8443, 27480-1, 27780, 27890, 28028, 28400

UNDER-DASH VEHICLE CONTROL HARNESS CONNECTOR PIN ASSIGNMENTS (Certain Models Only)

If the end of the harness already has a connector, skip to the next section. If the end of the harness has 10 socket-type terminals, follow the instructions in this section to install the terminals into the connector housing.

1. In the cab, pass the 10 socket-type terminals through the vehicle harness bracket.
2. Insert each of the 10 socket-type terminals into the connector housing. Refer to chart below.

NOTE: You will feel a snap as the terminals are successfully inserted. An extraction tool is provided for removing pin terminals if necessary. Keep this tool for future use.

Wire Color	Pin No.
Light Blue w/ Orange Stripe	1
Blue w/ Orange Stripe	2
Black w/ White Stripe	3
Light Green	4
Light Blue	5
White w/ Yellow Stripe	6
Brown w/ Red Stripe	7
Red w/ Yellow Stripe	8
Black w/ Orange Stripe	9
Brown w/ Green Stripe	10

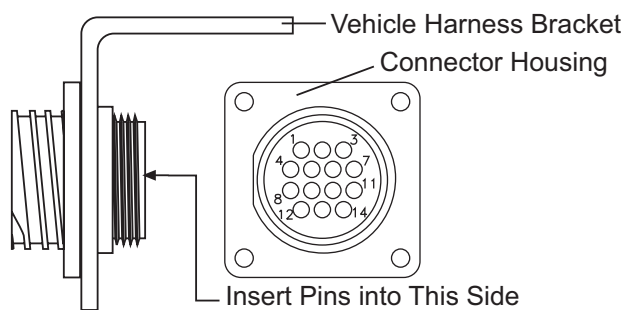

3. Attach the vehicle harness bracket to the vehicle with the supplied #8-18 x 5/8" tapping screws. Secure the connector housing to the vehicle harness bracket with #6 x 1/4" tapping screws and lock washers.

NOTE: Cable tie control harness and accessory tap away from any moving parts, brake, clutch, gas or parking brake pedals.

BATTERY CABLE CONNECTIONS

Top Post Batteries w/Lead Cable Ends

1. Attach the POSITIVE (+) OEM cable to the battery post. Attach the red battery cable to the bolt in the OEM terminal with the original fastener.
2. Attach the NEGATIVE (-) OEM cable to the battery post. Attach the black wire from the vehicle battery cable to the OEM terminal bolt with the original fastener.

Top Post Batteries w/Stamped Steel Battery Terminals

Top Post Batteries, Style One

These terminals are secured with a 6mm washer-head cap screw and nut.

1. If the cap screw is long enough for the added thickness of the cable terminal, washer, and nut, it will not need to be replaced, and Step 2 may be skipped.
2. Carefully lift retainer tabs (if present), and remove the short cap screw. Insert the supplied longer cap screw through a 3/16" washer and into the hole in the clamp. Carefully bend the retainer tabs back into place.

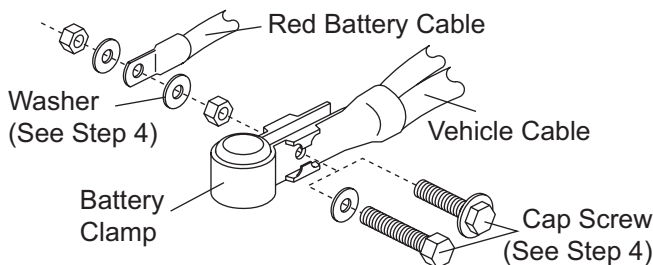

3. Attach POSITIVE (+) OEM battery clamp to battery post, and secure clamp.
4. Place the red battery cable over the end of the battery terminal screw. If added terminal has large contact area with the battery clamp, retain with a washer and nut. If the terminal contact area is small (i.e., terminal hole almost passes over a 6mm nut), add a washer to both sides of the cable, and secure with a nut.
5. Connect the black wire from the vehicle battery cable and the OEM NEGATIVE (-) cable to the NEGATIVE (-) battery terminal following the same procedure used in Steps 1-4.

8436, 8437-1, 8438, 8439, 8442, 8443, 27480-1, 27780, 27890, 28028, 28400

Top Post Batteries, Style Two

These terminals are secured with a 6mm tapered nut and cam.

1. Make the connections to the POSITIVE (+) terminal as follows:
 - a. Remove cable assembly from battery post by loosening the nut. Trim plastic terminal cover as shown.

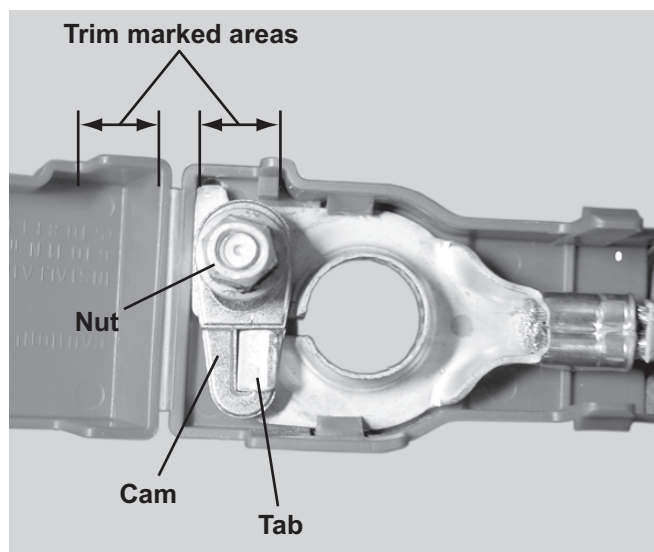

- b. Carefully bend tab securing the cam upward so the cam can be lifted off the stamped terminal after the nut has been removed.
 - c. Place the red battery cable over the battery terminal screw.
 - d. Slide the cam over the terminal screw and tab. Reinstall the nut.
 - e. Place cable assembly on battery post, align red battery cable with the opening in the cover, and tighten nut. Close plastic terminal cover.

2. Make the connections to the NEGATIVE (-) terminal as follows:

- a. Remove cable assembly from battery post by loosening the nut.
- b. Carefully bend tab securing the cam upward so the cam can be lifted off the stamped terminal after the nut has been removed.
- c. Place the black wire from the vehicle battery cable over the battery terminal screw.

- d. Slide the cam over the terminal screw and tab. Reinstall the nut.
- e. Place cable assembly on battery post, and tighten nut.

Top Post Batteries, Style Three

These terminals are similar to Style Two, but do not have a visible cam or tab.

1. Make the connections to the POSITIVE (+) terminal as follows:
 - a. Remove cable assembly from battery post by removing the nut. Trim plastic terminal cover as necessary to accommodate the red snowplow battery cable.
 - b. Place the red battery cable over the battery terminal screw and reinstall the nut.
 - c. Place cable assembly on battery post, align red battery cable with the opening in the cover, and tighten nut. Close plastic terminal cover.
2. Make the connections to the NEGATIVE (-) terminal as follows:
 - a. Remove cable assembly from battery post by removing the nut.
 - b. Place the black wire from the vehicle battery cable over the battery terminal screw and reinstall the nut.
 - c. Place cable assembly on battery post, and tighten nut.

Side Terminal Batteries

1. Use the furnished battery cable adapter to attach the red battery cable to the POSITIVE (+) terminal of the battery. Position the cable, and tighten the adapter to 124–178 in-lb.
2. Connect the OEM POSITIVE (+) cable to the adapter on the battery. Position the cable, and while holding the adapter, tighten the battery cable bolt to 124–178 in-lb.
3. Connect the black wire from the vehicle battery cable and the OEM NEGATIVE (-) cable to the NEGATIVE (-) battery terminal following the same procedure used in Steps 1 and 2.

8436, 8437-1, 8438, 8439, 8442, 8443, 27480-1, 27780, 27890, 28028, 28400

RECOMMENDED SPLICING PROCEDURE

1. Locate wire to be spliced into.
2. Cut wire at least 1-1/2" from any other splice, connector, or terminal. If wires are covered by tubing or braid, remove enough of it to achieve the minimum clearance required.
3. Strip away 5/16" of the insulation from the ends of the wires to be spliced.
4. Slide two wires into one end of the supplied parallel splice.
5. Place a piece of heatshrink tubing (3/16" x 1-1/4" long) over the remaining wire to be spliced. Cut tubing into 1-1/4" lengths if required.
6. Insert wire into the open end of the splice and crimp using an appropriate crimp tool. One or two crimps may be necessary to ensure a good connection. No wire strands should be visible outside of the splice.
7. Preheat a soldering tool for at least one minute to help promote even solder flow.
8. Apply heat to the splice. Avoid heating too close to the insulation. Apply solder to the wires. Use just enough solder to produce an even flow through the splice. **Use rosin core solder ONLY. Do not use acid core solder.**

NOTE: Avoid using an excessive amount of solder as it can result in wicking. Wicking occurs when solder travels up the wire core. This may cause the wire to become stiff or brittle which could lead to a broken or open circuit.

9. Check circuits for continuity.
10. Cover the splice with heatshrink tubing. The tubing should extend beyond the splice on both sides.
11. Using a hot air source, starting in the center and working to either side, apply heat until the tubing recovers and glue can be seen around the edges. Allow the tubing to cool before handling.

NOTE: The splices supplied will accommodate 18-gauge wires as shown. For larger gauge wires, cut the wire, strip the ends 3/8" to 1/2", and twist together. Apply solder to the splice and cover with heatshrink tubing.

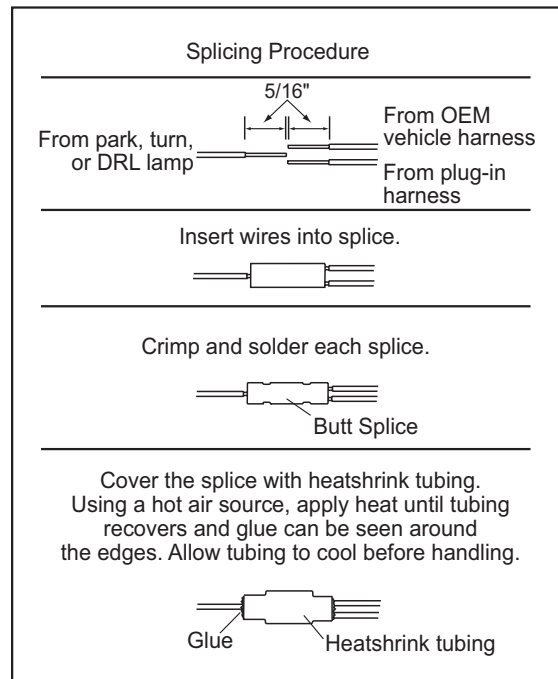

8436, 8437-1, 8438, 8439, 8442, 8443, 27480-1, 27780, 27890, 28028, 28400

The company reserves the right under its product improvement policy to change construction or design details and furnish equipment when so altered without reference to illustrations or specifications used. This equipment manufacturer or the vehicle manufacturer may require or recommend optional equipment for snow removal. Do not exceed vehicle ratings with a snowplow. The company offers a limited warranty for all snowplows and accessories. See separately printed page for this important information.

Printed in U.S.A.
