

PUMP SHAFT SEAL REPAIR KIT

REMOVING DAMAGED PUMP SHAFT SEALS

1. Remove the reservoir, pump, pump alignment ring and motor from the hydraulic manifold.

NOTE: Not all hydraulic units use an alignment ring.

⚠ CAUTION

Use care when removing the pump shaft seal. Any damage to the ID of the bearing sleeve or the pump shaft seal bore will degrade the performance and life of your hydraulic system.

2. From the motor side of the manifold, insert a nonmetal dowel or punch. Use a lightweight hammer to gently drive the seal out of the bore.

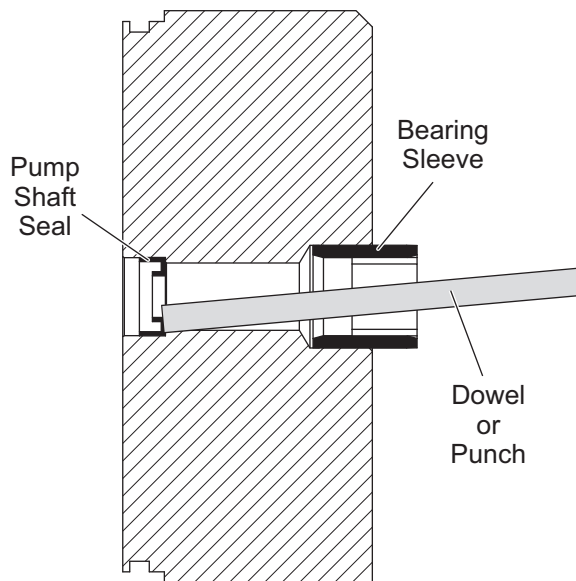

INSERTING NEW PUMP SHAFT SEALS

⚠ CAUTION

Once this procedure has been completed, make sure that the pump shaft seal hasn't been damaged before reassembling the hydraulic unit.

1. After the damaged pump shaft seal has been removed, install the new pump shaft seal onto the puller as shown, and place it into the bore on the reservoir side of the manifold block.

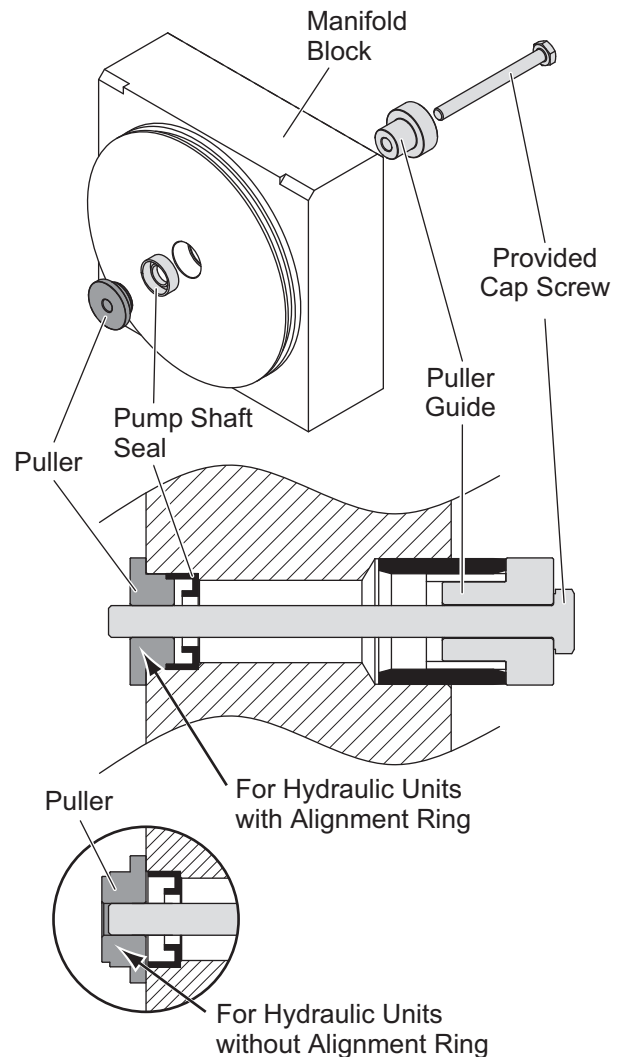

2. Install the puller guide onto the supplied cap screw, and hand turn the cap screw into the puller from the motor side of the manifold.
3. Turn the cap screw into the puller until the puller contacts the manifold block.
4. Remove the cap screw, puller and puller guide.

PUMP INSTALLATION AND ALIGNMENT

1. Place the pump alignment ring into the pump shaft seal bore of the manifold.

NOTE: Not all hydraulic units use an alignment ring.

2. Install the pump shaft seal bullet onto the tang of the pump shaft.
3. Generously coat the bullet and pump shaft with the recommended hydraulic fluid, and insert the pump shaft into the manifold block.
4. Remove the pump shaft bullet, and install the pump fasteners, but do not tighten.

5. **For hydraulic units using an alignment ring:** Alternately tighten the pump fasteners to 150–160 in-lb.

For hydraulic units not using an alignment ring: Insert the pump alignment tool into the bearing sleeve and over the pump shaft. With the alignment tool in place, alternately tighten the pump fasteners to 150–160 in-lb, then remove the pump alignment tool.

⚠ CAUTION

If the OD of the alignment tool is marred, it will damage the motor bearing sleeve. Store the tool in the supplied rubber tubing.

Hydraulic Units Using an Alignment Ring

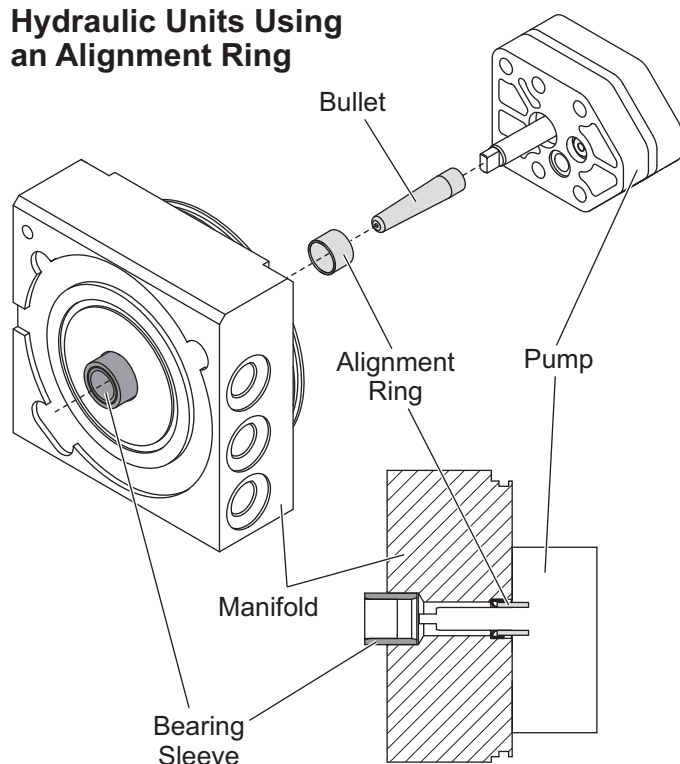

Hydraulic Units Not Using an Alignment Ring

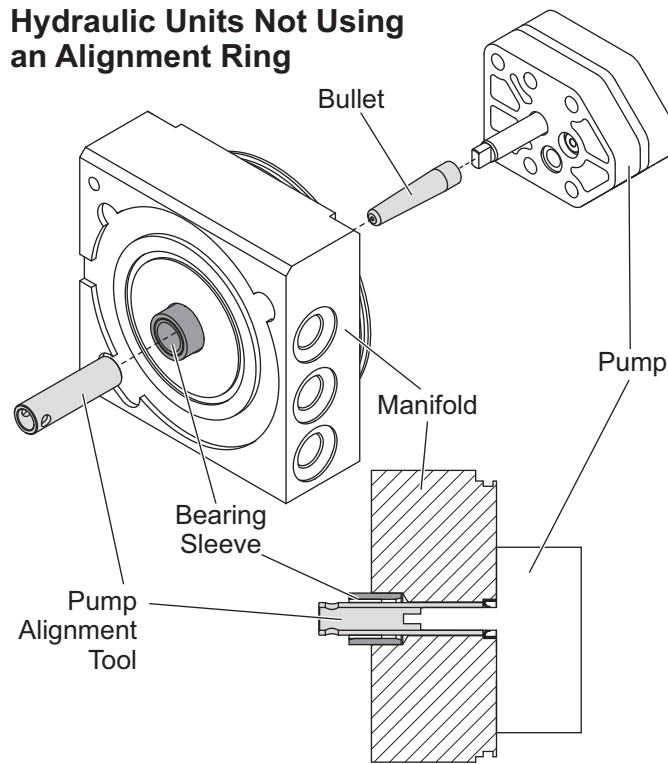

NOTE: Refer to the information on the following page for hydraulic assembly information.

HYDRAULIC UNIT ASSEMBLY

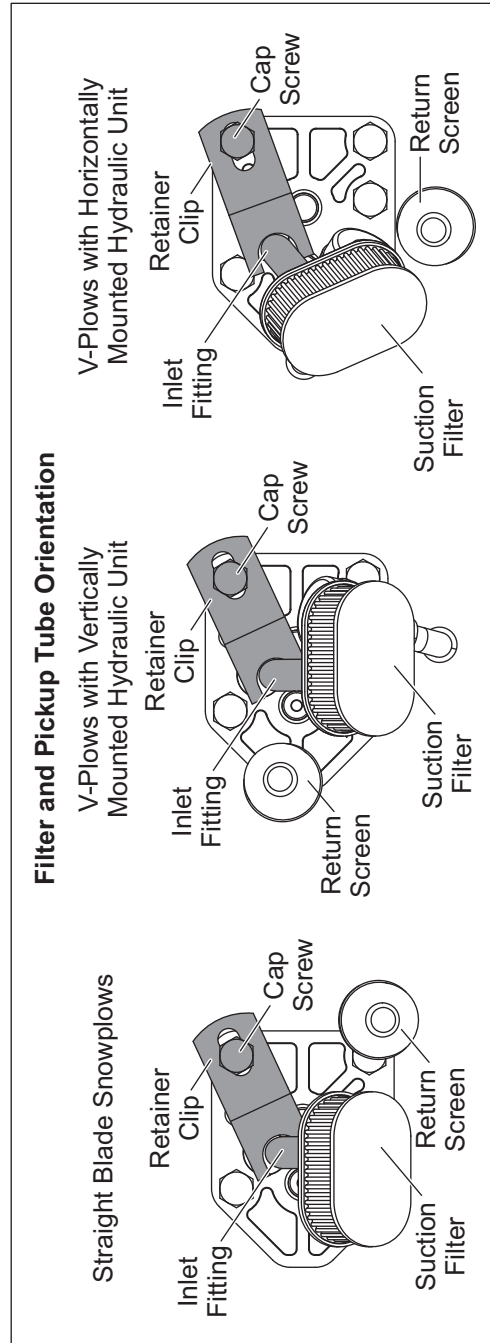
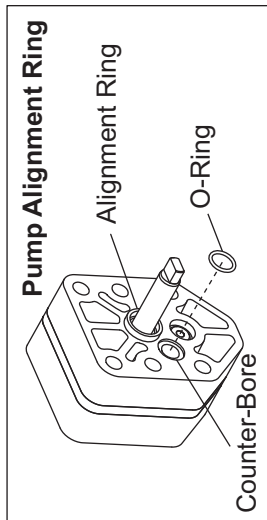
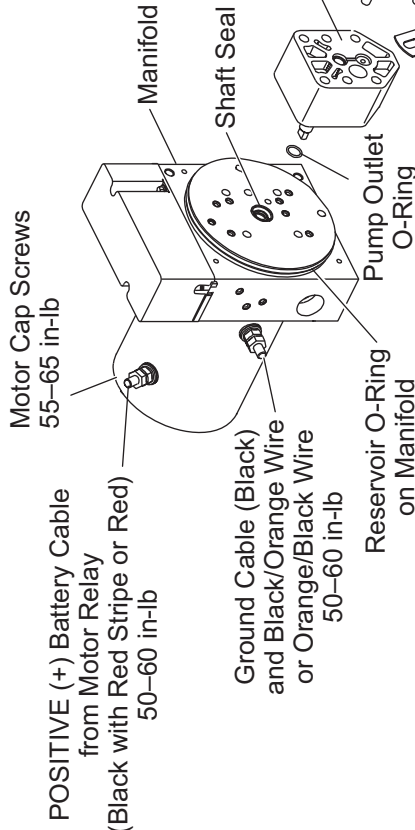
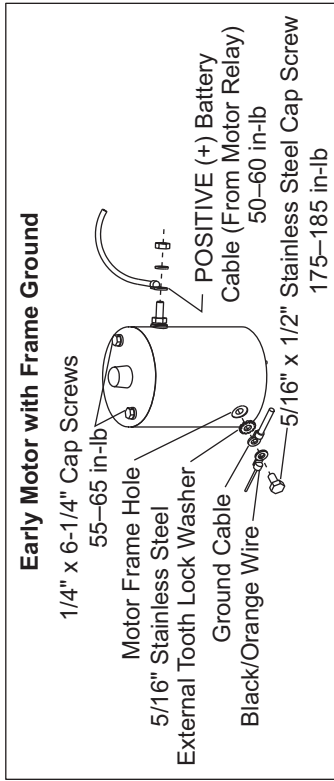

The company reserves the right under its product improvement policy to change construction or design details and furnish equipment when so altered without reference to illustrations or specifications used. Do not exceed vehicle ratings with a snowplow. The company offers a limited warranty for all snowplows and accessories. See separately printed page for this important information.

Printed in U.S.A.
