

www.storksplovs.com
Adapter Kit H13
Installation Instructions

NOTE: Instructions for installing H13 headlamps and headlamp harnesses are included with the headlamps (Lit. No. 28810). Please refer to that document until instructed to install the adapters.

ADAPTER INSTALLATION

1. Remove the four screws from the snowplow headlamp bezel and separate the headlamp halves.
2. Cut all wires connected to the 3-position plastic connector, insulated crimp connectors and ring terminal approximately 1-1/2" from the end.

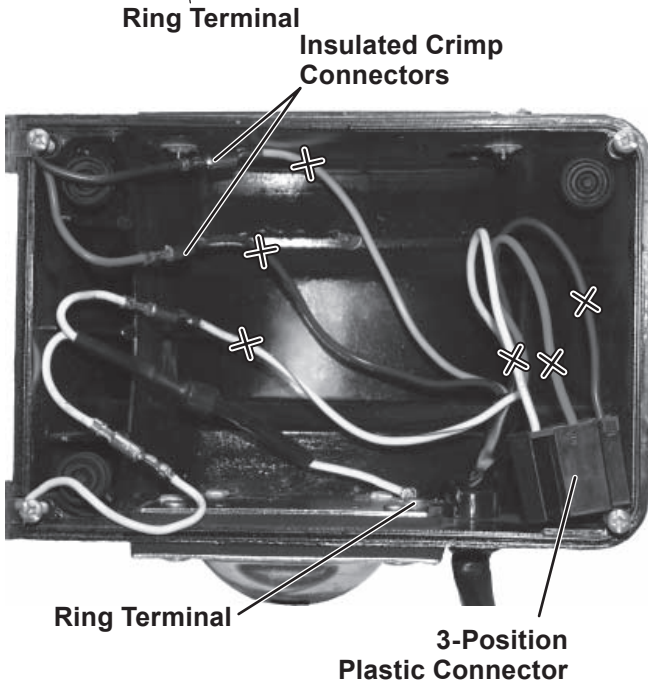
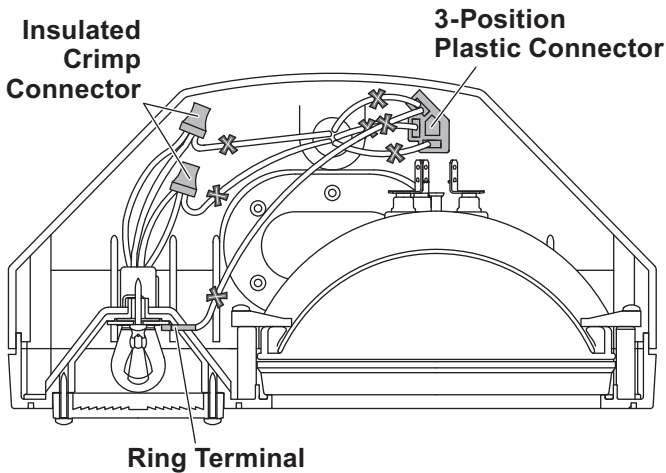

3. Remove the harness strain relief, then remove the harness from the headlamp housing along with any loose wires previously attached to the ring terminal.

4. Splice the headlamp and park/turn adapters onto to the harness as shown according to the recommended splicing procedure.

6-Pin Headlamps

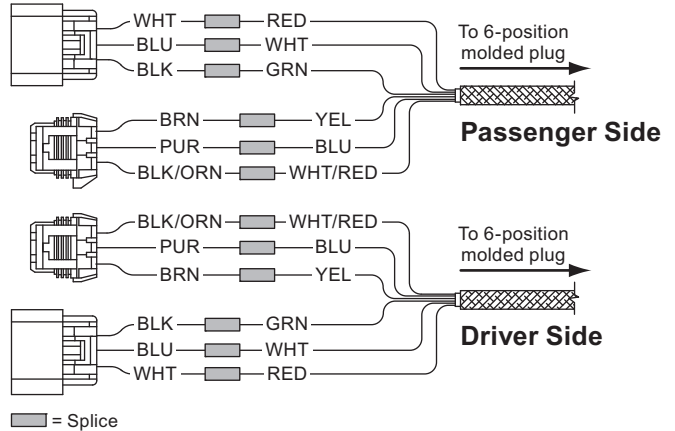

7- and 9-Pin Headlamps

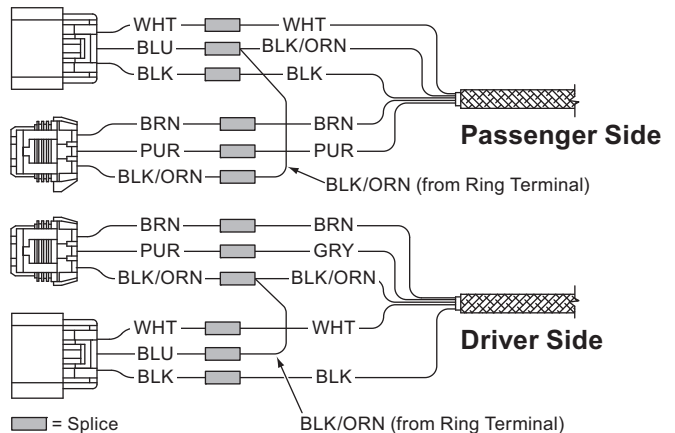

11-Pin Headlamps

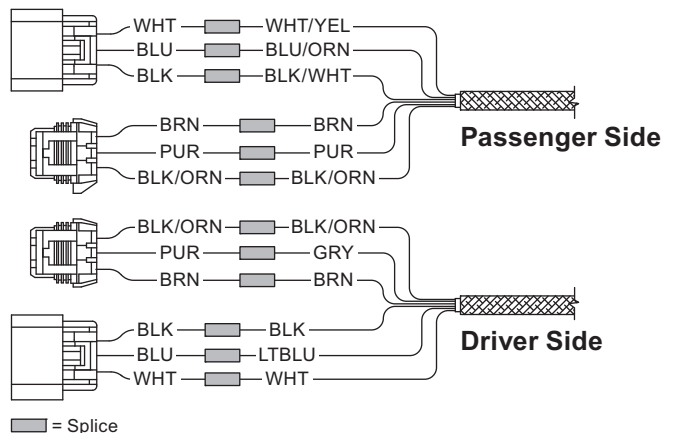

29033

12-Pin Headlamps

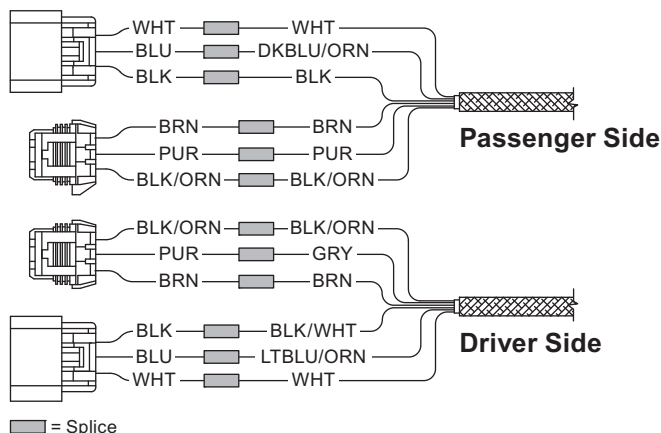

NOTE: Avoid using an excessive amount of solder as it can result in wicking. Wicking occurs when solder travels up the wire core. This may cause the wire to become stiff or brittle which could lead to a broken or open circuit.

9. Check circuits for continuity.
10. Cover the splice with heatshrink tubing. The tubing should extend beyond the splice on both sides.
11. Using a hot air source, starting in the center and working to either side, apply heat until the tubing recovers and glue can be seen around the edges. Allow the tubing to cool before handling.

RECOMMENDED SPLICING PROCEDURE

1. Locate wire to be spliced into.
2. Cut wire at least 1-1/2" from any other splice, connector or terminal. If wires are covered by tubing or braid, remove enough of it to achieve the minimum clearance required.
3. Strip away 5/16" of the insulation from the ends of the wires to be spliced.
4. Slide one wire into one end of the supplied parallel splice.
5. Place a piece of heatshrink tubing (3/16" x 1-1/4" long) over the remaining wire(s) to be spliced. Cut tubing into 1-1/4" lengths if required.
6. Insert remaining wire(s) into the open end of the splice and crimp using an appropriate crimp tool. One or two crimps may be necessary to ensure a good connection. No wire strands should be visible outside of the splice.
7. Preheat a soldering tool for at least one minute to help promote even solder flow.
8. Apply heat to the splice. Avoid heating too close to the insulation. Apply solder to the wires. Use just enough solder to produce an even flow through the splice. **Use rosin core solder ONLY. Do not use acid core solder.**

NOTE: The splices supplied will accommodate 18-gauge wires as shown. For larger gauge wires, cut the wire, strip the ends 3/8" to 1/2", and twist together. Apply solder to the splice and cover with heatshrink tubing.

Splicing Procedure

From park, turn or DRL Lamp From OEM vehicle harness
From plug-in harness

5/16"

Insert wires into splice.

Crimp and solder each splice.

Butt Splice

Cover the splice with heatshrink tubing. Using a hot air source, apply heat until tubing recovers and glue can be seen around the edges. Allow tubing to cool before handling.

Glue Heatshrink tubing

The company reserves the right under its product improvement policy to change construction or design details and furnish equipment when so altered without reference to illustrations or specifications used. This equipment manufacturer or the vehicle manufacturer may require or recommend optional equipment for snow removal. Do not exceed vehicle ratings with a snowplow. The company offers a limited warranty for all snowplows and accessories. See separately printed page for this important information.