



Fisher Engineering

50 Gordon Drive, Rockland, Maine 04841-2139 • www.fisherplows.com

January 15, 2009
Lit. No. 29042, Rev. 03

Minute² **Mount[®]** **SYSTEM**

MOUNT KIT

GM K2500 w/8600 GVW	1988 - 00
GM K3500	1988 - 00
GM K2500 Suburban w/8600 GVW	1992 - 00

Installation Instructions

⚠ CAUTION

Read this document before installing the snowplow.

⚠ CAUTION

See your FISHER[®] outlet/Web site for specific vehicle application recommendations before installation. The Kit Selection Guide has specific vehicle and snowplow requirements.

SAFETY DEFINITIONS

⚠ WARNING

Indicates a potentially hazardous situation that, if not avoided, could result in death or serious personal injury.

⚠ CAUTION

Indicates a potentially hazardous situation that, if not avoided, may result in minor or moderate injury. It may also be used to alert against unsafe practices.

NOTE: Indicates a situation or action that can lead to damage to your snowplow and vehicle or other property. Other useful information can also be described.

WARNING/CAUTION AND INSTRUCTION LABELS

Become familiar with and inform users about the warning labels on the back of the blade and the instruction label on the headgear.

NOTE: If labels are missing or cannot be read, see your sales outlet.

Warning/Caution Label

⚠ WARNING

LOWER BLADE WHEN VEHICLE IS PARKED.
DO NOT EXCEED GVWR OR GAWR INCLUDING BLADE AND BALLAST.
REMOVE BLADE ASSEMBLY BEFORE PLACING VEHICLE ON HOIST.

⚠ CAUTION

READ OWNER'S MANUAL BEFORE OPERATING OR SERVICING SNOWPLOW.
TRANSPORT SPEED SHOULD NOT EXCEED 45 MPH. FURTHER REDUCE SPEED UNDER ADVERSE TRAVEL CONDITIONS.
PLOWING SPEED SHOULD NOT EXCEED 10 MPH.
SEE YOUR SALES OUTLET/WEB SITE FOR SPECIFIC VEHICLE APPLICATION RECOMMENDATIONS.

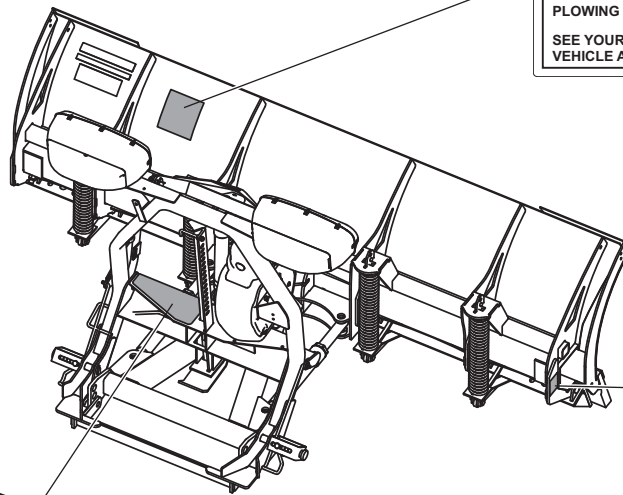

Multiple Pinch Points Label



**XLS™ Blades Only
(both sides)**

Instruction Label

U.S. Patents 4,999,835; 5,353,530; 5,420,480; 6,253,470; 6,944,978; RE 35,700; CAN Patent 2,060,425; and other patents pending.

Read Owner's Manual For Complete Instructions

1. Place control in Lower/Float to put blade down.
2. Pull and hold Jack Lock out. Jack will drop to ground. Then pull Pin Release Handle away from Stop and Jack Lock. Release Jack Lock. Verify Jack is locked by trying to lift Jack.

3. Stand in front of blade. While pushing Headgear toward vehicle with left hand, push Pin Release Handle down to disengage Connecting Pins. Make sure Connecting Pins are fully retracted. If unable to push Headgear from in front of blade, stand in front of Headgear on driver side and push Headlamp Bracket.
4. Detach all electrical connectors.

ATTACH
DETACH

SAFETY PRECAUTIONS

Improper installation and operation could cause personal injury and/or equipment and property damage. Read and understand labels and the Owner's Manual before installing, operating or making adjustments.

⚠ WARNING

Lower blade when vehicle is parked. Temperature changes could change hydraulic pressure, causing the blade to drop unexpectedly or damaging hydraulic components. Failure to do this could result in serious personal injury.

⚠ WARNING

The driver shall keep bystanders clear of the blade when it is being raised, lowered or angled. Do not stand between the vehicle and the blade or within 8 feet of a moving blade. A moving or falling blade could cause personal injury.

⚠ WARNING

Keep hands and feet clear of the blade and A-frame when mounting or removing the snowplow. Moving or falling assemblies could cause personal injury.

⚠ WARNING

Do not exceed GVWR or GAWR including the blade and ballast. The rating label is found on the driver-side vehicle door cornerpost.

⚠ WARNING

To prevent accidental movement of the blade, always turn the ON/OFF switch to OFF whenever the snowplow is not in use. The control indicator light will turn off.

⚠ WARNING

Remove blade assembly before placing vehicle on hoist.

⚠ CAUTION

Refer to the Kit Selection Guide for minimum vehicle recommendations and ballast requirements.

PERSONAL SAFETY

- Remove ignition key and put the vehicle in park or in gear to prevent others from starting the vehicle during installation or service.
- Wear only snug-fitting clothing while working on your vehicle or snowplow.
- Do not wear jewelry or a necktie, and secure long hair.
- Wear safety goggles to protect your eyes from battery acid, gasoline, dirt and dust.
- Avoid touching hot surfaces such as the engine, radiator, hoses and exhaust pipes.
- Always have a fire extinguisher rated BC handy, for flammable liquids and electrical fires.

FIRE AND EXPLOSION

⚠ WARNING

Gasoline is highly flammable and gasoline vapor is explosive. Never smoke while working on vehicle. Keep all open flames away from gasoline tank and lines. Wipe up any spilled gasoline immediately.

Be careful when using gasoline. Do not use gasoline to clean parts. Store only in approved containers away from sources of heat or flame.

CELL PHONES

A driver's first responsibility is the safe operation of the vehicle. The most important thing you can do to prevent a crash is to avoid distractions and pay attention to the road. Wait until it is safe to operate Mobile Communication Equipment such as cell phones or two-way radios.

VENTILATION



⚠ WARNING

Vehicle exhaust contains lethal fumes. Breathing these fumes, even in low concentrations, can cause death. Never operate a vehicle in an enclosed area without venting exhaust to the outside.

TORQUE CHART

⚠ CAUTION

Read instructions before assembling. Fasteners should be finger tight until instructed to tighten according to the torque chart. Use standard methods and practices when attaching snowplow including proper personal protective safety equipment.

Recommended Fastener Torque Chart (ft-lb)			
Size	 SAE Grade 2	 SAE Grade 5	 SAE Grade 8
1/4-20	6	9	13
5/16-18	11	18	28
3/8-16	19	31	46
3/8-24	24	46	68
7/16-14	30	50	75
1/2-13	45	75	115
9/16-12	66	110	165
5/8-11	93	150	225
3/4-10	150	250	370
7/8-9	150	378	591
1-8	220	583	893
Metric Grade 8.8 (ft-lb)			
Size	Torque	Size	Torque
M 6	7	M 12	60
M 8	17	M 14	95
M 10	35	M 16	155
These torque values apply to fasteners except those noted in the instruction.			

INSTALLATION INSTRUCTIONS

NOTE: For easier assembly and installation, vehicle and all snowplow components should be on a smooth, level, hard surface, such as concrete.

1. Remove and discard tow hooks.
 2. Place the bolting bar inside the frame on the driver's side. Check the bottom of the frame for any weld overlapping the frame. If so, grind flat with the frame. The fastener on the mud shield may have to be loosened to place the side tab of the pushplate up against the frame. Place the pushplate under the frame. Install two $1/2 \times 1-1/2$ " cap screws with a flat washer up through the pushplate, frame and into the threaded holes in the bolting bar. Tighten.
- ⚠ CAUTION**

Use caution not to pinch, cut or drill through any wires or hoses running along the frame rail.
3. Drill two $17/32$ " holes through the frame using the two holes on the tab on the inside of the frames as guides. Install two $1/2 \times 1-1/2$ " cap screws and $1/2$ " flat washer from inside the frame, out through the frame and the holes in the tabs. Fasten with two $1/2$ " locknuts.
 4. Repeat Steps 2 and 3 on the passenger's side of the vehicle.
 5. Tighten all fasteners according to the torque chart.

6. Check the center-to-center dimension between the connecting pin arms. This measurement should be $29-1/8$ ".

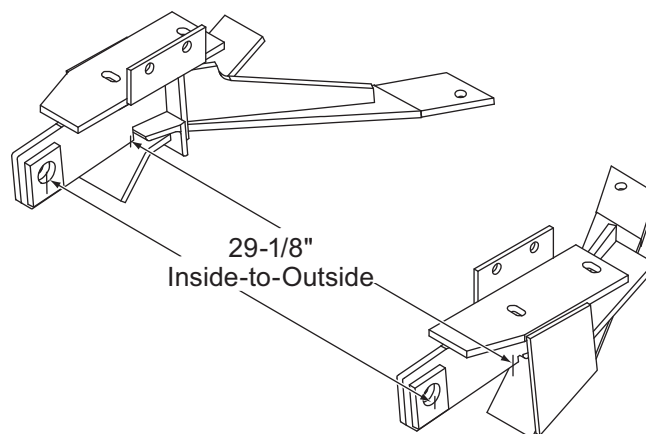

If the measurement is not $29-1/8$ " and the plates are not parallel, loosen all fasteners and remove the $1/2 \times 1-1/2$ " cap screws holding the tab on the frame for each pushplate. Slide $5/8$ " flat washers between the tab, one for each hole, and the frame, as needed. Reinsert the cap screws. Tighten all fasteners in the same order as installed.

7. Check the center-to-center dimension between the connecting pin arms again. Repeat Step 6 as needed to obtain the $29-1/8$ " dimension.
8. Drill a $1/2$ " hole into the cross member of the frame using the rear hole in the rear leg of the pushplate as a guide. Install a $1/2 \times 1-1/2$ " cap screw with flat washer down through the hole in the cross member on the vehicle and the rear hole in the rear leg of the pushplate. Fasten with $1/2$ " lock washer and nut. Tighten all fasteners according to the torque chart.

NOTE: After five to ten hours of snowplow usage, retorque all pushplate assembly fasteners.

Fisher Engineering reserves the right under its product improvement policy to change construction or design details and furnish equipment when so altered without reference to illustrations or specifications used. Fisher Engineering or the vehicle manufacturer may require or recommend optional equipment for snow removal. Do not exceed vehicle ratings with a snowplow. Fisher Engineering offers a limited warranty for all snowplows and accessories. See separately printed page for this important information. The following are registered (®) trademarks of Douglas Dynamics, L.L.C.: FISHER®, Minute Mount® 2.

Printed in U.S.A.
