



WESTERN PRODUCTS
 P.O. BOX 245038
 MILWAUKEE, WI 53224-9538
 www.westernplows.com

dd A DIVISION OF DOUGLAS DYNAMICS, L.L.C.

27170
UltraMount® – UniMount®
CONVERSION KIT

Parts List & Installation Instructions

PARTS LIST

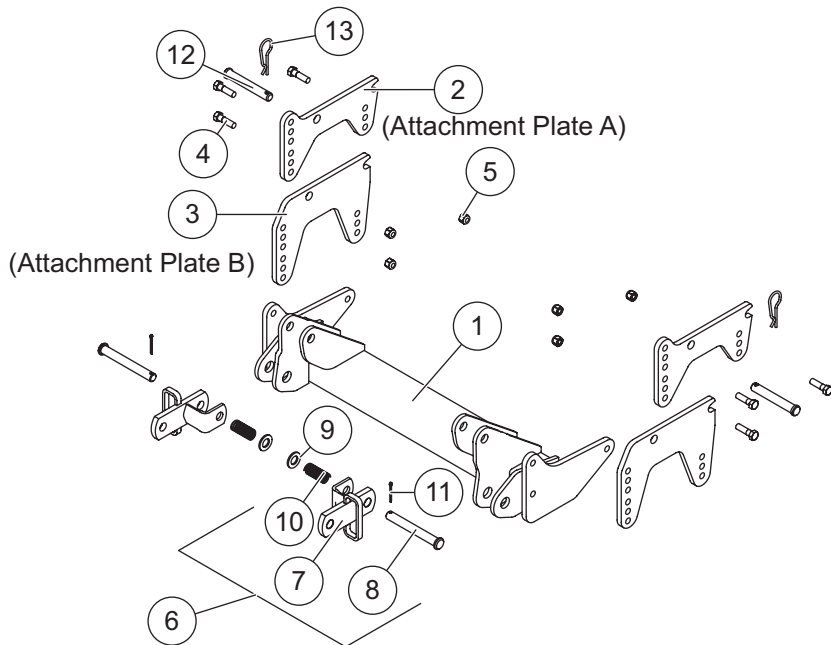

27170 CONVERSION KIT UltraMount – UniMount							
Item	Part	Qty	Description	Item	Part	Qty	Description
1	40271	1	MOUNT ADAPTER	5	91335	6	1/2-13 HEX LOCKNUT GB
2	40278	2	ATTACHMENT PLATE A	6	63940	2	LINK ARM SERVICE KIT
3	40279	2	ATTACHMENT PLATE B	12	95739	2	3/4 X 5 CLEVIS PIN
4	90101	6	1/2-13 X 1-3/4 HEX CAP SCREW G5	13	91965	2	5/32 HAIRPIN COTTER
63940 LINK ARM SERVICE KIT							
7	63497	1	LINK ARM	10	63356	1	3/4 X 3 SPRING
8	63354	1	3/4 X 6 CLEVIS PIN HEAT-TREATED	11	91911K	1	5/32 X 1-1/2 COTTER PIN KIT
9	91147	1	3/4 FLAT WASHER				
G = GRADE							

⚠ WARNING
 Do not exceed GVWR or GAWR, including blade and ballast. The rating label is found on the driver-side vehicle door cornerpost.

⚠ CAUTION
 Use standard methods and practices when attaching snowplow and installing accessories including proper personal protective safety equipment.

⚠ CAUTION
 Read this document before installing the Conversion Kit.

⚠ CAUTION
 See your WESTERN® outlet/Web site for specific vehicle application recommendations before installation. Conversion Kit weight information may be found in the Selection List.

27170 UltraMount® – UniMount® CONVERSION KIT

Conversion Kit Assembly

⚠ WARNING

Conversion kit use is limited to vehicles up to 19,500 GVWR.

Selection Lists cannot be used to qualify vehicles for use with the conversion kit. To qualify vehicle and determine ballast, you must fill out the Vehicle and Plow Application Inquiry Sheet or use the ballast calculator on Quick Match.

This conversion kit allows a WESTERN® UniMount snowplow assembly to be installed on a vehicle equipped with a

WESTERN UltraMount vehicle mount. This kit can be assembled to allow for six height adjustments to obtain the necessary 9-1/2" to 10-1/2" coupling distance for attaching a WESTERN UniMount snowplow.

Prior to assembling the conversion kit, install Attachment Plate A to the vehicle mount and measure the distance from the top of the attachment plate to the ground as shown in DIAGRAM A ("d" dimension). Bolt the indicated attachment plates to the mount adapter in the appropriate position as shown in DIAGRAM B.

Tighten fasteners to 75 ft-lb.

DIAGRAM A

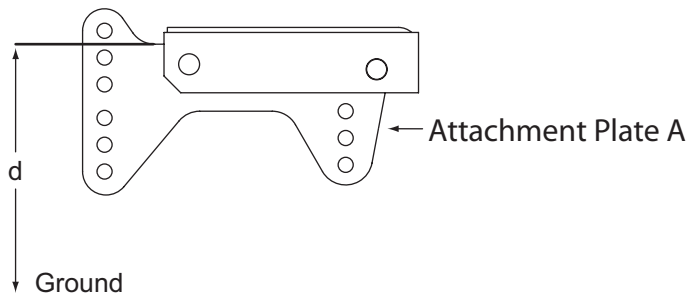
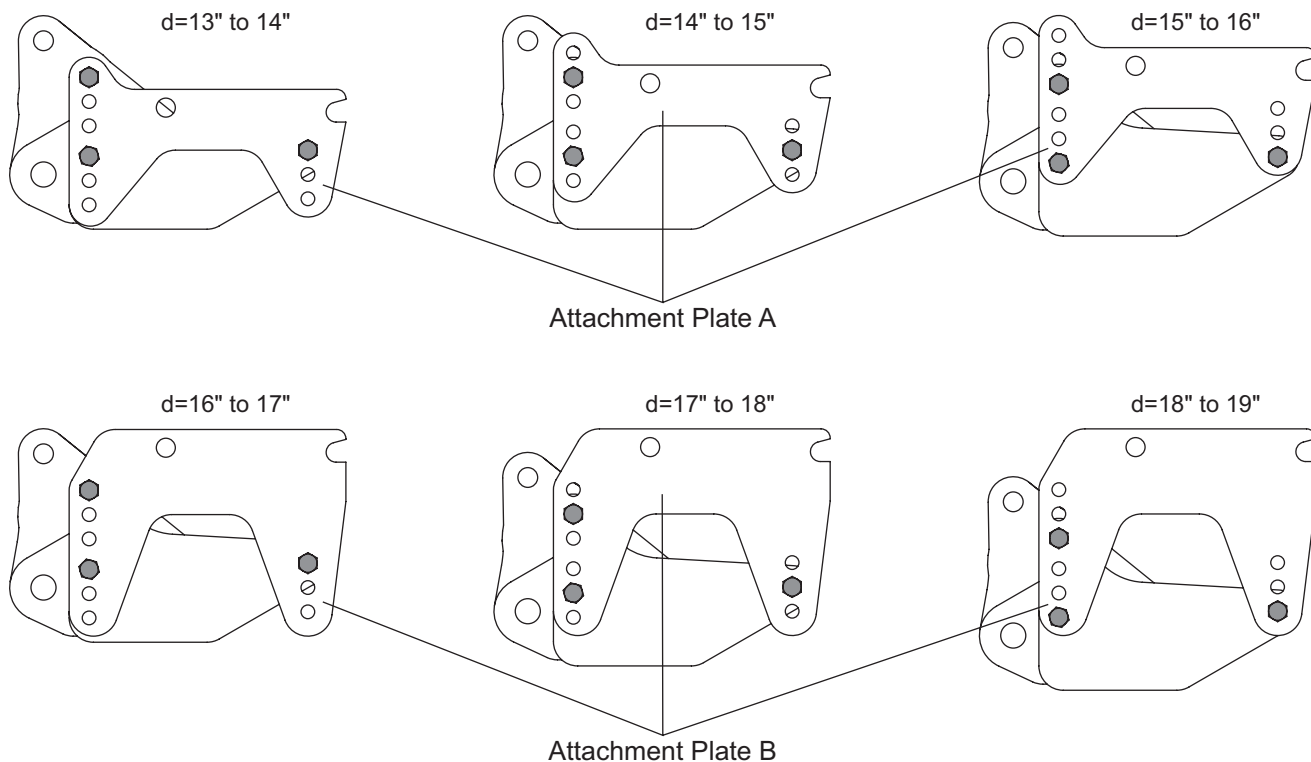

DIAGRAM B



27170 UltraMount® – UniMount® CONVERSION KIT

INSTALLATION INSTRUCTIONS

1. Park the vehicle on a smooth, level, hard surface, such as concrete. Lower the blade to the ground, and turn the control to the "OFF" position. Disconnect the snowplow from the vehicle, or turn the vehicle ignition to the "OFF" position and remove the key.
2. Slide the rear notch of the conversion kit attachment plate over the pin at the rear of the mount. Rotate the front of the attachment plate upward into the mount U-bracket until the holes in the mount line up with the hole through the attachment plate. Insert the 3/4" x 5" clevis pin into the aligned holes of the mount and attachment plate, and insert the hairpin cotter into the hole of the clevis pin (see photo).

Repeat for other side.

NOTE: Additional bumper air dam notching may be required to attach the Conversion Kit.

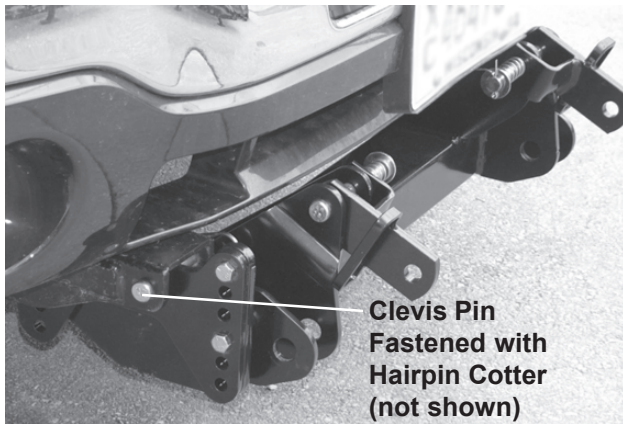

Link Arm Installation

Assemble link arm assembly to mount with one 6" clevis pin, 3" spring, washer and cotter pin. The spring should push the link arm assembly to the outside of the mount.

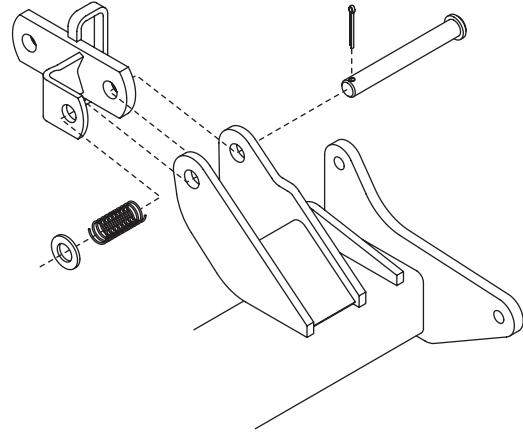

Coupling Lug Height Check

1. Mount snowplow to vehicle. (See label on back of blade or Owner's Manual for mounting instructions.) Add recommended ballast.
2. With the blade on a level surface, slack in lift chain and rear ballast located behind rear wheels, the center of the coupling holes (hitch pin) to level surface should measure 9-1/2" to 10-1/2".

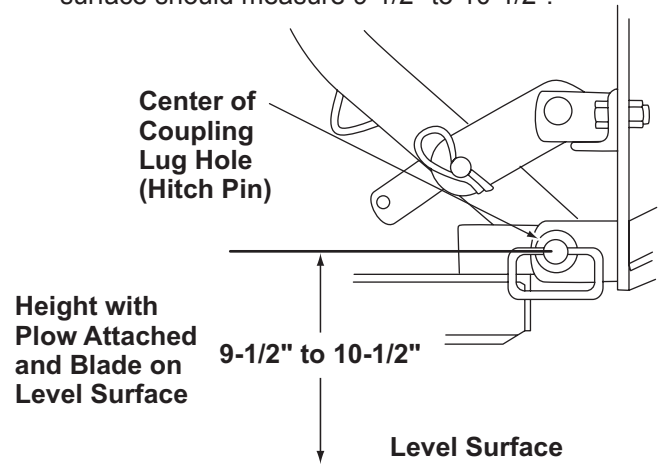

If 9-1/2" to 10-1/2" distance is not obtained, adjust conversion kit upward or downward to obtain proper distance.

NOTE: Coupling height must be 9-1/2" minimum to allow stand to be pinned to frame.

3. Adjust chain slack with snowplow mounted to vehicle and lift channel pushed all the way down. To adjust, remove chain from hook, straighten chain and pull tight. Rehook it to the lift channel. After chain is hooked, it will have the correct amount of slack for blade "float". DO NOT remove chain from lift channel when removing snowplow from vehicle.

Copyright © 2007 Douglas Dynamics, L.L.C. All rights reserved. This material may not be reproduced or copied, in whole or in part, in any printed, mechanical, electronic, film or other distribution and storage media, without the written consent of Western Products. Authorization to photocopy items for internal or personal use by Western Products outlets or snowplow owner is granted.

Western Products reserves the right under its product improvement policy to change construction or design details and furnish equipment when so altered without reference to illustrations or specifications used. Western Products or the vehicle manufacturer may require or recommend optional equipment for snow removal. Do not exceed vehicle ratings with a snowplow. Western Products offers a limited warranty for all snowplows and accessories. See separately printed page for this important information. The following are registered (®) or unregistered (™) trademarks of Douglas Dynamics, L.L.C.: UltraMount®, UniMount®, WESTERN®.

Printed in U.S.A.
